

## DX-9100 Configuration Guide

| <b>DX-9100 Extended Digital Plant Controller</b>               | <b>Page</b> | <b>5</b>  |
|--|-------------|-----------|
| • <i>Introduction</i>  |             | *5        |
| • <i>Hardware Configuration</i>                                |             | 10        |
| <b>Software Configuration</b>                                  |             | <b>11</b> |
| • <i>DX-9100 Software Elements</i>                             |             | 11        |
| • <i>Configuration Tools</i>                                   |             | 11        |
| • <i>Configuring the Controller</i>                            |             | 14        |
| • <i>DX-9100 Controller Selection</i>                          |             | 15        |
| • <i>DX-9100 Global Data</i>                                   |             | 15        |
| • <i>Configuration Number (Version 1.1 or Later)</i>           |             | 17        |
| • <i>Password Feature (Versions 1.4, 2.3, 3.3, or Later)</i>   |             | 17        |
| • <i>Analog Input Configuration</i>                            |             | 18        |
| • <i>Digital Input Configuration</i>                           |             | 25        |
| • <i>Analog Output Configuration</i>                           |             | 26        |
| • <i>Digital Output Configuration</i>                          |             | 32        |
| • <i>DO: Output Type</i>                                       |             | 34        |
| • <i>Constants and Result Status</i>                           |             | 40        |
| • <i>Extension Module Configuration</i>                        |             | *42       |
| • <i>Network Analog Input Configuration (Version 3 Only)</i>   |             | *51       |
| • <i>Network Digital Input Configuration (Version 3 Only)</i>  |             | 52        |
| • <i>Network Analog Output Configuration (Version 3 Only)</i>  |             | 53        |
| • <i>Network Digital Output Configuration (Version 3 Only)</i> |             | 55        |
| • <i>Programmable Function Module Configuration</i>            |             | 57        |
| • <i>Control Algorithm Theory</i>                              |             | 63        |

\* Indicates those sections where changes have occurred since the last printing.

|   | <b>Page</b> |  |
|---|-------------|--|
| • <i>Algorithm 01 - PID Control Module</i>                                  | 65          |  |
| • <i>Algorithm 02 - On/Off Control Module</i>                               | 78          |  |
| • <i>Algorithm 03 - Heating/Cooling PID Control Module (Dual PID)</i>       | 86          |  |
| • <i>Algorithm 04 - Heating/Cooling On/Off Control Module (Dual On/Off)</i> | 98          |  |
| • <i>Numerical Calculation and Other Function Module Configurations</i>     | 107         |  |
| • <i>Algorithm 11 - Average</i>   | 107         |  |
| • <i>Algorithm 12 - Minimum Select</i>                                      | 109         |  |
| • <i>Algorithm 13 - Maximum Select</i>                                      | 111         |  |
| • <i>Algorithm 14 - Psychrometric Calculation °C</i>                        | 113         |  |
| • <i>Algorithm 15 - Psychrometric Calculation °F</i>                        | 116         |  |
| • <i>Algorithm 16 - Line Segment</i>  | 119         |  |
| • <i>Algorithm 17 - Input Selector</i>                                      | 121         |  |
| • <i>Algorithm 18 - Calculator</i>  | 123         |  |
| • <i>Algorithm 19 - Timer Functions</i>                                     | 125         |  |
| • <i>Algorithm 20 - Totalization</i>  | 129         |  |
| • <i>Algorithm 21 - Comparator</i>  | 133         |  |
| • <i>Algorithm 22 - Sequencer</i>   | 136         |  |
| • <i>Algorithm 23 - Four Channel Line Segment (Version 1.1 or Later)</i>    | 152         |  |
| • <i>Algorithm 24 - Eight Channel Calculator (Version 1.1 or Later)</i>     | 154         |  |
| • <i>Time Program Functions</i>   | 156         |  |
| • <i>Time Schedule Configuration</i>  | 157         |  |
| • <i>Optimal Start/Stop Configuration</i>                                   | 161         |  |
| • <i>Programmable Logic Control Configuration</i>                           | 174         |  |
| • <i>Dial-up Feature with an NDM</i>  | *188        |  |
| • <i>Trend Log (Versions 1.4, 2.3, 3.3, or Later)</i>                       | 192         |  |
| • <i>Supervisory Mode Control Settings (General Module)</i>                 | *195        |  |
| • <i>Controller Diagnostics</i>   | 204         |  |
| • <i>Power Up Conditions</i>  | 204         |  |
| • <i>Download/ Upload</i>   | *206        |  |
| • <i>Calibration Values</i>   | 209         |  |

\* Indicates those sections where changes have occurred since the last printing.

|  |                 |
|--|-----------------|
| <b>Appendix A: SX Tool Item Description and Tables</b>   | <b>Page 211</b> |
| • <i>Description of Items</i>                            | 211             |
| • <i>Item List</i>                                       | 213             |
| • <i>Floating Point Numbers</i>                          | 215             |
| • <i>EEPROM Items</i>                                    | 215             |
| <br>   |                 |
| <b>Appendix B: Item Structure</b>                        | <b>217</b>      |
| • <i>General Module Items Structure</i>                  | *217            |
| • <i>Programmable Function Module Items Structure</i>    | 223             |
| • <i>Analog Input Module Items Structure</i>             | 226             |
| • <i>Analog Output Module Items Structure</i>            | 228             |
| • <i>Digital Output Module Items Structure</i>           | 229             |
| • <i>Extension Module Items Structure</i>                | 230             |
| • <i>Time Scheduling Items Structure</i>                 | *236            |
| • <i>Optimal Start/Stop Items Structure</i>              | 237             |
| • <i>Network Information Module Items Structure</i>      | 238             |
| • <i>Network Digital Output Module Items Structure</i>   | 239             |
| • <i>Network Analog Output Module Items Structure</i>    | 241             |
| • <i>Network Digital Input Module Items Structure</i>    | 243             |
| • <i>Network Analog Input Module Items Structure</i>     | 244             |
| <br>   |                 |
| <b>Appendix C: Programmable Function Module Items</b>    | <b>247</b>      |
| • <i>Algorithm 1 - PID Controller</i>                    | 247             |
| • <i>Algorithm 2 - On/Off Controller</i>                 | 249             |
| • <i>Algorithm 3 - Heating/Cooling PID Controller</i>    | 251             |
| • <i>Algorithm 4 - Heating/Cooling On/Off Controller</i> | 253             |
| • <i>Algorithm 11 - Average Calculation</i>              | 256             |
| • <i>Algorithm 12 - Minimum Selection</i>                | 257             |
| • <i>Algorithm 13 - Maximum Selection</i>                | 258             |
| • <i>Algorithm 14 - Psychrometric Calculation °C</i>     | 259             |

\* Indicates those sections where changes have occurred since the last printing.

|  |                 |
|--|-----------------|
| • <i>Algorithm 15 - Psychrometric Calculation °F</i>                         | <b>Page</b> 260 |
| • <i>Algorithm 16 - Line Segment Function</i>                                | 261             |
| • <i>Algorithm 17 - Input Selector</i>                                       | 262             |
| • <i>Algorithm 18 - Calculator</i>   | 263             |
| • <i>Algorithm 19 - Timer Function</i>                                       | 264             |
| • <i>Algorithm 20 - Totalization</i>   | 266             |
| • <i>Algorithm 21 - Eight Channel Comparator</i>                             | 269             |
| • <i>Algorithm 22 - Sequencer</i>  | 271             |
| • <i>Algorithm 23 - Four Channel Line Segment Function</i>                   | 274             |
| • <i>Algorithm 24 - Eight Channel Calculator</i>                             | 276             |
| <b>Appendix D: Logic Variables</b>   | <b>279</b>      |
| • <i>Description of Logic Variables</i>                                      | 279             |
| • <i>Logic Variable Tables</i>   | 280             |
| <b>Appendix E: Analog Items and Logic Variables for the Trend Log Module</b> | <b>*287</b>     |

\* Indicates those sections where changes have occurred since the last printing.

# DX-9100 Extended Digital Plant Controller

---

---

## ***Introduction***

This document covers all three versions of the DX-9100 Extended Digital Controller, including the DX-912x LONWORKS® version. They include:

Version 1 – provides up to eight output modules, which are configured to give two analog outputs and six digital outputs (triacs).

Version 2 – provides six additional analog output modules, giving a total of eight analog outputs.

Version 3 – the DX-912x LONWORKS version brings peer-to-peer communication to the feature set of the Version 2 controller, and enhanced alarm reporting capability when used as an integral part of a Building Automation System (BAS).

In this document, BAS is a generic term, which refers to the Metasys® Network, Companion™, and Facilitator™ supervisory systems. The specific system names are used when referring to system-specific applications.

The DX-9100 is the ideal digital control solution for multiple chiller or boiler plant control applications, for the Heating, Ventilating, and Air Conditioning (HVAC) process of air handling units or for distributed lighting and related electrical equipment control applications. It provides precise Direct Digital Control (DDC) as well as programmed logic control.

In a standalone configuration, the DX-9100 Controller has both the hardware and software flexibility to adapt to the variety of control processes found in its targeted applications. Along with its outstanding control flexibility, the controller can expand its input and output point capability by communicating with I/O Extension Modules on an expansion bus, and provides monitoring and control for all connected points via its built-in Light-Emitting Display (LED). Versions 1 and 2 can communicate on the N2 Bus as well as on the System 91 Bus\*, providing point control to the full BAS Network or to the N30 system or Companion/Facilitator System. The Version 3 controller uses the LONWORKS (Echelon®) N2 Bus of the Metasys Control Module (NCM311 or NCM361 in Europe, NCM300 or NCM350 elsewhere) in place of the N2 Bus.

\*The terms System 91 Bus and Metasys Control Station are not used in North America.

The DX-9100 has two packaging styles. In Version 1, all terminals for field wiring are located within the controller enclosure. Versions 2 and 3 require a separate field wiring mounting base or cabinet door mounting frame, which enables all field wiring to be completed before the controller is installed.



**Figure 1: Version 1 (DX-9100-8154)**

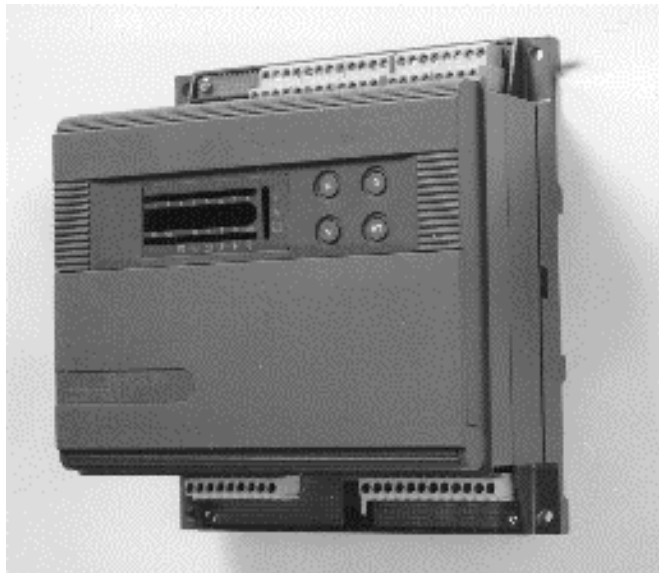

**Figure 2: DX-9100-8454 (Version 2)/DX-912x-8454 (Version 3)  
with Mounting Base**

Note: The mounting base differs for DX-9120 and DX-9121.

The DX-9100 processes the analog and digital input signals it receives, using twelve multi-purpose programmable function modules, a software implemented Programmable Logic Controller (PLC), time schedule modules, and optimal start/stop modules; producing the required outputs (depending on the module configuration), operating parameters, and programmed logic.

Configuration of all versions of the DX-9100 Controller are achieved by using a Personal Computer (PC) with GX-9100 Graphic Configuration Software (Version 5 or later) supplied by Johnson Controls. Changes to the configuration can be made by using an SX-9120 Service Module (Version 3.1 or later).

**Versions 1 and 2  
(N2 Bus)**

The DX-9100 unit (Versions 1 and 2) has two communication links. One is called the N2 Bus or Bus 91 (the term Bus 91 is not used in North America) and is used to interface to a supervisory unit. The other link is called the XT Bus and is used to expand the DX-9100 input/output capability by interfacing up to eight XT-9100 or XTM-905 extension modules. The DX-9100 input/output can be extended by up to 64 remote input/outputs, analog or digital, depending on the type of the connected extension modules and XP expansion modules.

Point connections are made on XP modules, which are monitored and controlled by the XT-9100 or XTM-905 modules. For more details, refer to the *XT-9100 Technical Bulletin* in the *System 9100 Manual (FAN 636.4 or 1628.4)*. One XP module can provide either eight analog points or eight digital points. Two XP modules connected to one extension module provides eight analog and eight digital points, or sixteen digital points.

Version 1 or 2 of the DX-9100 can be used as a standalone controller or it can be connected to a BAS through the RS-485 serial communications bus (N2 Bus or Bus 91).

**Version 3  
(LONWORKS  
N2 Bus)**

**Version 3** of the controller (DX-912x-8454) brings peer-to-peer communication to the feature set of the Version 2 controller, and enhanced alarm reporting capability when used as an integral part of a Metasys BAS Network.

The new communications features are provided by the LONWORKS Network, which enables Version 3 controllers to pass data from one to another and to send event-initiated data to the NCM350 (NCM361 in Europe) Network Control Module, in the BAS. The LONWORKS (Echelon) N2 Bus is used in place of the N2 Bus, and the NCM300 or NCM350 (NCM311 or NCM361 in Europe) must be fitted with a LONWORKS (Echelon) driver card.

The Version 3 controller retains all the input/output point and control capabilities of the Version 2 controller, including the point expansion feature using extension modules and expansion modules.

In addition to the Version 2 features, the Version 3 controller has network input and output points, which can be configured to transmit and receive data over the LONWORKS Bus. Each controller may have up to 16 network analog input modules, 16 network analog output modules, 8 network digital input modules, and 8 network digital output modules. While network analog input and output modules each contain a single analog value, the network digital input and output modules each contain 16 digital states, which are transmitted as a block between controllers. The transmission of point data is managed by the LONWORKS Network and is independent of the supervisory functions of the BAS Network Control Module (NCM). A network of Version 3 controllers can be installed to share analog and digital data between controllers on a peer-to-peer basis; a Network Control Module is not required unless the network is to be supervised by a BAS.

Complex control strategies may now be performed in multiple DX-912x controllers without the need for network data exchange routines in a supervisory controller. Applications include the control of multiple, interdependent air handling units, and large hot water or chilled water generating plants with components distributed in various locations within the building.

**LONMARK®  
Compatibility**

The Version 3 controller has been approved as a LONMARK device and conforms to the LONMARK specification for network data transmission.



**Figure 3: LONMARK Trademark**

Further information about compatibility and interoperability with other LONMARK devices may be requested from your local Johnson Controls office.



**Related  
Information**

Refer to Table 1 for additional information on System 9100 controllers:

**Table 1: Related Information**

| <b>Document Title</b>  | <b>Code Number</b> | <b>FAN</b>    |
|--|--------------------|---------------|
| <i><b>DX-9100 Extended Digital Controller Technical Bulletin</b></i> | <i>LIT-6364020</i> | 636.4, 1628.4 |
| <i><b>DX-9100 Configuration Guide</b></i>                            | <i>LIT-6364030</i> | 636.4, 1628.4 |
| <i><b>GX-9100 Software Configuration Tool User's Guide</b></i>       | <i>LIT-6364060</i> | 636.4, 1628.4 |
| <i><b>LONWORKS N2 Bus Technical Bulletin</b></i>                     | <i>LIT-6364100</i> | 636.4         |
| <i><b>XT-9100 Technical Bulletin</b></i>                             | <i>LIT-6364040</i> | 636.4         |
|  | <i>LIT-1628440</i> | 1628.4        |
| <i><b>XT-9100 Configuration Guide</b></i>                            | <i>LIT-6364050</i> | 636.4         |
|  | <i>LIT-1628450</i> | 1628.4        |
| <i><b>NDM Configurator Application Note</b></i>                      | <i>LIT-6364090</i> | 636.4         |
|  | <i>LIT-1628490</i> | 1628.4        |
| <i><b>Scheduling Technical Bulletin</b></i>                          | <i>LIT-636116</i>  | 636           |
| <i><b>Point History Technical Bulletin</b></i>                       | <i>LIT-636112</i>  | 636           |
| <i><b>SX-9100 Service Module User's Guide</b></i>                    | <i>LIT-6364070</i> | 636.4         |
|  | <i>LIT-1628470</i> | 1628.4        |

---

**Hardware Configuration**

For full details of the hardware configuration, refer to the *DX-9100 Extended Digital Controller Technical Bulletin (LIT-6364020)* and the *XT-9100 Technical Bulletin (LIT-6364040)*.

In summary, the DX-9100 has the following interfaces, inputs, and outputs:

- Versions 1 and 2**
- One N2 Bus (Bus 91) RS-485 port for BAS communication
- Version 3**
- One LONWORKS N2 Bus for BAS communication and peer-to-peer communication with other controllers on the same bus (maximum of 30 controllers on one LONWORKS Bus)
- All Versions**
- One XT Bus (RS-485 port) for up to 8 extension modules and a maximum of 64 inputs/outputs
  - One port for service module (SX-9120) communication
  - Eight digital input ports for connection to voltage-free contacts
  - Eight analog input ports; the DX-9100 accepts 0-10 VDC or 0-20 mA signals from active sensors, or can be connected to Nickel 1000 (Johnson Controls or DIN standard), Pt1000, or A99 passive RTD sensors, as selected via jumpers on the circuit board
  - Six isolated triac digital outputs to switch external 24 VAC circuits with devices such as actuators or relays
- Version 1**
- Two analog output ports, 0-10 VDC or 0-20 mA, as selected via jumpers on the circuit board; also, 4-20 mA may be selected by configuration
- Versions 2 and 3**
- Four analog outputs, 0-10 VDC or 0-20 mA, as selected via jumpers on the circuit board; also, 4-20 mA may be selected by configuration
  - Four additional analog outputs, 0-10 VDC only
  - One RS-232-C port for local downloading and uploading software configurations (N2 Bus protocol)

The software configuration determines how these inputs and outputs are used, and their range and application.

The DX-9100 must be supplied with a 24 VAC power source. All models are suitable for 50 Hz or 60 Hz through software configuration.

# Software Configuration

---

---

## ***DX-9100 Software Elements***

The DX-9100 is a microprocessor-based programmable controller. It has the following software elements:

- eight analog input modules
- eight digital input modules
- two analog output modules in **Version 1**;  
eight analog output modules in **Versions 2 and 3**
- six digital output modules
- up to 64 additional inputs/outputs from up to 8 extension modules
- twelve programmable function modules with algorithms for control and calculation
- eight analog constants and 32 digital constants
- one programmable logic control module with 64 logic result statuses
- eight time schedule modules
- two optimal start/stop modules

## **Version 3 Only**

- sixteen network analog input modules
- eight network digital input modules
- sixteen network analog output modules
- eight network digital output modules

---

## ***Configuration Tools***

A user configures the controller using the GX-9100 Graphic Software Configuration Tool. The SX-9120 Service Module is used to troubleshoot and adjust individual parameters. Techniques for both tools are described in the following sections.

For complete documentation on both tools, see the *GX-9100 Software Configuration Tool User's Guide* and the *SX-9120 Service Module User's Guide* in *FAN 636.4* or *1628.4*.

Following is a brief description of the main features of the GX-9100 Software Configuration Tool. Note that the term, click on, means to position the cursor on the module or menu and then press the appropriate mouse button to select it.

Note: When using the GX Tool, after entering a parameter, always click on **OK** to confirm.

## Entering Data into Modules

To enter data into a module displayed on the screen of the GX Tool, place the cursor on the module, click once on the right mouse button and the module menu will appear:

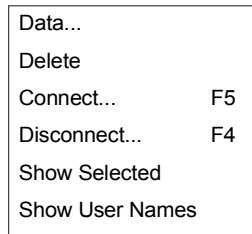

dxcon004

**Figure 4: Module Menu**

Place the cursor on Data and press *either* mouse button. A Data Window appears containing all module data. Use the <Tab> key or mouse to move the cursor from field to field. To make an entry, move the cursor to the entry field and type in the information. To go to the second page in the Data Window (if there is one), click on the Data-2 field. To return to the first page, click on OK or Cancel.

To exit a window, click on OK to confirm entries, or Cancel to discard them, while in the first page.

## Entering Values

The following table shows the accuracy that may be lost due to rounding errors. Numbers with a modulus of greater than 2047 may be rounded up or down by 0.1% as follows:

**Table 2: Rounding Errors**

| Range       | Rounding (+/-) |
|-------------|----------------|
| 2048-4095   | 2              |
| 4096-8191   | 4              |
| 8192-16383  | 8              |
| 16384-32767 | 16             |

The rounding is due to the external communications bus protocol and does not compromise the precision of the internal control processes.

## Entering User Names

The Data Window contains User Name and Description entry fields. Up to 8 characters may be entered in the User Name field, and the Description field can have up to 24 characters.

The Data Window also contains an Output Tag field for module outputs (i.e., source points), which can be connected to another module as inputs (destinations) and an Input Tag field for module inputs. To enter User Names for outputs, position the cursor over the Output Tag field and press the left mouse button once. To enter User Names for inputs, select the Input Tag field.

## Making Connections

To expand a module displayed on the screen of the GX Tool, in order to view input/output connections, place the cursor over the module and double-click on the left mouse button. Input connections appear in the left column with @ attached to the Tag Name, and output connections are shown in the right column, except for output modules where all connections appear in one column. To close a module, place the cursor over the expanded module and double-click on the left mouse button.

Connections are made using one of the four methods outlined below. Note that only the first method is referred to later in this guide. An existing connection must be disconnected before making a new connection.

- The first method is to expand the source and destination modules by moving the cursor to each module in turn and double-clicking the left mouse button. Move the cursor over the desired output of the source module and the cursor appears as an output arrow. Hold down the left mouse button and drag the arrow to the desired destination input. When the left mouse button is released, a connection line will be drawn between the two modules.
- The second method is to select the source module by positioning the cursor over the module and pressing the left mouse button and then the <F5> key. A list of the possible source output connections for that module will be shown. Move the cursor to the desired output to select it (it will appear highlighted) and click on OK (alternatively, double-click on the desired output). To complete the connection, select the destination module by pressing the left mouse button and then the <F5> key. A list of the possible destination inputs for that module will be shown. Select the desired destination from the dialog box and click on **OK** (alternatively, double-click on the desired destination). A connection line will be drawn between the two modules.

- The third method is to select the source module by positioning the cursor over it and pressing the right mouse button. The module menu will appear. Select **Connect** and a list of possible source outputs for that module will appear in a dialog box. Move the cursor to the desired output to select it (it will appear highlighted) and click on **OK** (alternatively, double-click on the desired output). Then select the destination module by positioning the cursor on it and pressing the right mouse button. The module menu will appear. Select **Connect** and a list of possible destination inputs for that module will be shown. Move the cursor to the desired input to select it and click on **OK** (alternatively, double-click on the desired input). A connection line will be drawn between the two modules.
- The fourth method is to go to the destination module data window, move the cursor to a connection field, press the <\*> key on the keyboard, and the available source output tags will be displayed for selection.

---

## **Configuring the Controller**

Configuring the controller involves:

- defining characteristics and parameters of the input and output modules, the programmable function modules for control and calculation, the extension modules, and the programmable logic control module
- defining connections between the modules in order to achieve the desired sequence of control
- setting the time scheduling, optimal start/stop, and realtime clock parameters

Proceed in the following order:

1. Select the controller type (Versions 1, 2, or 3).
2. Define DX-9100 **Global Data** under the **Edit** menu.
3. Define **Job Information** under the **Edit** menu.
4. Define analog and digital input characteristics.
5. Define analog and digital output characteristics.
6. Define extension module structures and characteristics.
7. When applicable, define network inputs and outputs for the Version 3 controller (LONWORKS Bus).
8. Define programmable function module/algorithm characteristics.
9. Define time schedule and exception day settings.
10. Define programmable logic control module.

---

**DX-9100  
Controller  
Selection****Via GX Tool**

Select the controller version under the Controller menu:

- DX Version 1.1, 1.2, 1.3, or
- DX Version 1.4, or
- DX Version 2.0, 2.1, 2.2, or
- DX Version 2.3, 2.4 or
- DX Version 3.0, 3.1, 3.2, or
- DX Version 3.3 or 3.4

**Via the SX Tool**

The SX Tool will display the controller type when first connected to the controller. No user selection is required.

---

**DX-9100 Global  
Data****Set Power Line  
Frequency  
(50 or 60 Hz)****Via the GX Tool**

At the menu bar at the top of the screen, select Edit-Global Data and a window appears. Under Frequency, click on 50 or 60 Hz. Then click on OK to confirm the setting. (To discard an entry, click on Cancel.)

**Via the SX Tool**

Under General Module, set bit X7 of Item DXS1 (RI.32):

- X7 = 0 50 Hz power line
- X7 = 1 60 Hz power line

**Set Initialize on  
Power Up Flag**

When this flag is set to cancel or 1, the override-type Items listed below are reset after each power up of the controller.

When set to maintained or 0, these override-type Items are maintained through the power failure.

- Shutoff mode request
- Startup mode request
- Enable Digital Output (Triac) Supervisory Control
- Set Digital Output (Triac) On
- Output Hold mode (Analog and Digital)
- Programmable Function Module Hold
- Time Schedule Module Hold mode

### ***Via the GX Tool***

Select **Edit-Global Data**. Under **Init. on Power Up**, click on maintained or cancelled.

### ***Via the SX Tool***

Under **General Module**, set bit X8 of Item **DXS1** (RI.32):

X8 = 0 No initialization on power up (commands from BAS maintained)

X8 = 1 Initialization on power up (commands from BAS cancelled)

## **Counter Type Flag**

In the controller, four bytes are reserved for digital input counters and accumulators in programmable modules. When the DX-9100 is connected to a BAS, the counter type flag must be set to 0 because the system will only read 15 bits (maximum reading of 32,767). For BASs that can read four bytes, or for standalone applications, the flag may be set to 1. The counter will then read a maximum value of 9,999,999 and then reset to 0. See *Supervisory Mode Control Settings (General Module)* further in this document.

### ***Via the GX Tool***

Select Edit-Global Data. Under Counter Type, click on one of the following:

- 15-bit (BAS)
- 4-byte

### ***Via the SX Tool***

Under General Module, set in bit X4 of Item DXS1 (RS.32):

X4 = 0 Selects 15-bit counters

X4 = 1 Selects 4-bit counters

## **Global Data Notes**

For temperature unit selection, refer to the *Analog Input Configuration* section below.

For daylight saving time, refer to the *Time Program Functions* section later in this document.



---

**Configuration Number**  
(Version 1.1 or Later)

A configuration number may be entered for configuration identification purposes. The number will be displayed on the front panel of the controller during initialization. The configuration number is also read and used by the DX LCD Display to identify which of the display configurations in its database to use for this controller.

**Via the GX Tool**

Select **Edit-Global Data**. Enter the appropriate number in the **User Config Code** field.

**Via the SX Tool**

Under **General Module**, enter the appropriate number in **Item ALG (RI.33)**.

---

**Password Feature**  
(Versions 1.4, 2.3, 3.3, or Later)

The password is used to protect a configuration when loaded into a controller. Once the password has been downloaded into the controller with the configuration, the controller will only allow a subsequent download or upload when the password is entered in the **Download** or **Upload** dialog box of the GX Software Configuration Tool. The password is encrypted by the GX Tool before download.

 **WARNING:** If the password is lost and the user does not have access to the original configuration file that includes the password, then the controller must be returned to the supplier or the Johnson Controls factory to have the memory cleared.

**IMPORTANT:** A password of 0 disables the protection feature.

The password feature is only available with firmware Versions 1.4, 2.3, 3.3, or later. In older versions, the password feature was not implemented.

**Note:** The password feature is enabled by an entry in the GX9100.ini file of the GX Tool. The GX Tool software is delivered without this entry. Refer to the *GX-9100 Software Configuration Tool User's Guide (LIT-6364060)* for details.

**Via the GX Tool**

Select **Edit-Global Data**. Enter the password (one to four alphanumeric characters) in the **Password** field. Enter 0 if the password feature is not required. The default password is 0000.

**Via the SX Tool**

The password cannot be accessed via the SX Tool. A GX Tool must be used.

---

## **Analog Input Configuration**

The DX-9100 Controller can accept up to eight analog inputs, which are active (voltage or current) or passive (RTD). Each analog input is defined and configured by the following parameters:

- User Name and Description (GX only)
- Input Signal/Range
- Measurement Units
- Enable Square Root
- Alarm on Unfiltered Value
- Alarm Limits
- Filter Time Constant

### **AI: Input Signal and Ranging**

#### ***Via the GX Tool***

To assign the input as active or passive, position the cursor on the appropriate box and double-click the left mouse button. Then position the cursor accordingly and click the left mouse button once to select either Active or Passive.

### **User Name and Description**

Select AIn using the right mouse button. Then select Data in the module menu, and enter as appropriate:

User Name (maximum 8 characters)

Description (maximum 24 characters)

For active inputs, at the Type of Active Input field, enter:

0 = 0-10 VDC

1 = 4-20 mA

2 = 0-20 mA

Each analog input module performs the conversion of the input signal to a variable numeric value expressed in engineering units obtained using the high range and low range.

High Range (HR) = Enter the equivalent number for reading at high signal input (10 V, 20 mA)

Low Range (LR) = Enter the reading at low signal input (0 V, 0 mA, 4 mA)

AI =  $(PR\% / 100) * (HR - LR) + LR$

where: PR% = analog value in % of physical input signal

For passive inputs at the **Type of Passive Input** field, enter:

1 = Ni1000 (Johnson Controls characteristic)

2 = Ni1000 Extended Temperature Range (Johnson Controls characteristic)

3 = A99 (Johnson Controls characteristic)\*

4 = Pt1000 (DIN characteristic)

5 = Ni1000 (L. & G. characteristic) (Firmware, Version 1.1 or later)

6 = Ni1000 (DIN characteristic) (Firmware, Version 1.1 or later)

\*Note: The North American Johnson Controls silicon sensors (TE-6000 series) have very similar characteristics to the A99 sensor. At 21°C (70°F) and 25°C (77°F) the reference values are identical. At -40°C (-40°F), the reading will be 0.8°C (1.5°F) high. At 38°C (100°F), the reading will be 0.3°C (0.5°F) high.

For Resistance Temperature Device (RTD) inputs, the range of the displayed value is fixed according to the type of sensor. The high/low range entries will not have any effect on the actual sensor readout. The configured high and low ranges determine the control range of any control module to which it is connected. (The difference between the High Range value and the Low Range value is equivalent to a proportional band of 100%.)

At the High/Low control range field, enter the required value:

High Range (Control) =

Low Range (Control) =

### ***Via the SX Tool***

Under Analog Inputs configure Item AITn (RI.00):

*(Low Byte)*

X7 = 0    0-10 Volts

X7 = 1    0-20 mA, 0-2 V or RTD

X8 = 1    20% suppression (2-10 V or 4-20 mA)

*(High Byte)*

|            |   |     |   |
|------------|---|-----|---|
| X11 X10 X9 | = | 000 | Active Sensor (Linear)  |
| X11 X10 X9 | = | 001 | Ni 1000 RTD Passive Sensor<br>(Johnson Controls)<br>(-45 to 121°C [-50 to 250°F]) |
| X11 X10 X9 | = | 010 | Ni 1000 RTD High Temperature<br>Sensor<br>(21 to 288°C [70 to 550°F])             |
| X11 X10 X9 | = | 011 | RTD Sensor A99 (Johnson Controls)<br>(-50 to 100°C [-58 to 212°F])                |
| X11 X10 X9 | = | 100 | RTD Sensor Platinum 1000 (DIN)<br>(-50 to 200°C [-58 to 392°F])                   |

### ***Version 1.1 or Later***

|            |   |     |  |
|------------|---|-----|--|
| X11 X10 X9 | = | 101 | Ni 1000 RTD (L. & G.)<br>(-50 to 150°C [-58 to 302°F]) |
| X11 X10 X9 | = | 110 | Ni 1000 RTD (DIN)<br>(-50 to 150°C [-58 to 302°F])     |

For active inputs, the analog input module performs the conversion of the input signal to a variable numeric value expressed in engineering units obtained using the high range at Item HRn (RI.01) and low range at Item LRn (RI.02).

For RTD passive inputs, the range of the displayed value is fixed according to the type of sensor. The configured range determines the control range of any control module to which it is connected.

### **AI: Measurement Units**

### ***Via the GX Tool***

To choose between Celsius and Fahrenheit for active and passive sensors, select Edit-Global Data. Under Temperature Units, select Celsius or Fahrenheit.

To set the measurement units for active sensors, select the AIn module, and then Data to call up the Data Window. Enter in the Measurement Units field:

0 = None

1 = Temperature (C or F as entered under Edit-Global Data)

2 = Percent (%) (Version 1 only)

In a Version 1 controller the units are displayed on the front panel of the controller as °t, %, or none.

***Via the SX Tool***

Under Analog Inputs, configure Item AITn (RI.00). The measurement and temperature units of each analog input can be selected with the following bits (low byte):

X4 X3 X2 X1 = 0000 No Units

X4 X3 X2 X1 = 0001 Celsius

X4 X3 X2 X1 = 0010 Fahrenheit

X4 X3 X2 X1 = 0011 Percent (Version 1 only)

For RTD sensor inputs, Celsius and Fahrenheit units must be selected. Changing individual units for each AI can only be done via the SX Tool.

**AI: Enable Square Root**

This function allows the linearization of the differential pressure signal from a 0-10 VDC or 0/4-20 mA active sensor; the function is effective over the selected range and is only available for active sensors.

$$AI = \text{sqrt} (PR\%/100) * (HR - LR) + LR$$

Where PR% = the Analog Value in % of the physical input signal range; HR = High Range Value; and LR = Low Range Value.

***Via the GX Tool (option only available with active sensor)***

Select AIn. Then select Data in the module menu. At the Square Root field, enter 0 to disable the square root function, or 1 to enable the square root function.

***Via the SX Tool***

Under Analog Inputs, configure Item AITn (RI.00) (low byte):

X5 = 1 Enable Square Root of Input

X5 = 0 Disable Square Root of Input

**AI: Alarm on Unfiltered Value**

An alarm from the High Limit and Low Limit Alarm values will be generated from the unfiltered input.

### ***Via the GX Tool***

Select AIn. Then select Data in the module menu. At the Alarm Unfiltered field, enter 0 to set an alarm on a filtered value, or 1 to set an alarm on an unfiltered value.

### ***Via the SX Tool***

Under Analog Inputs, configure Item AITn (RI.00) (low byte):

X6 = 1 Alarm on Unfiltered Value

X6 = 0 Alarm on Filtered Value

## **AI: Alarm Limits**

The high limit and the low limit define at which levels the analog input reading will generate an alarm, either for remote monitoring or for internal use within the control sequences in the DX-9100. A limit differential defines when a point comes out of alarm.

Note: The limits cannot be deleted. If you do not want alarms, enter limits beyond the high/low range of the sensor.

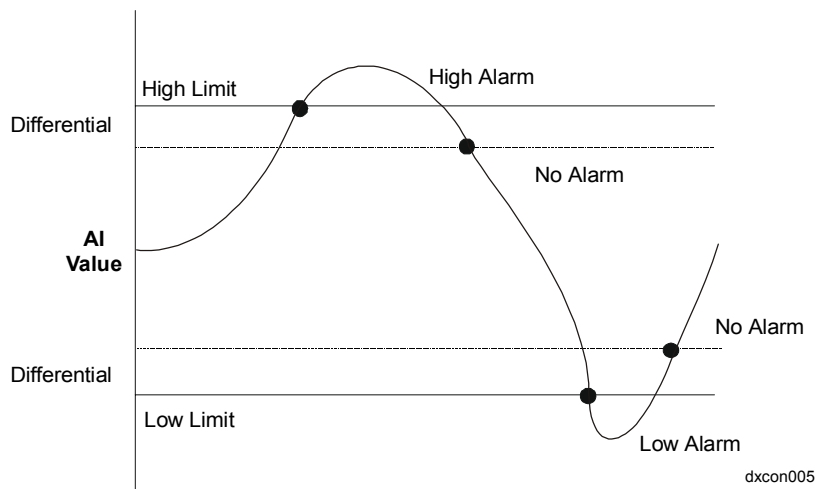

**Figure 5: How Alarm Limits Function**

### ***Via the GX Tool***

Select AIn. Then select Data in the module menu. At the respective field, enter the required value:

High Limit =

Low Limit =

Limit Differential =

The low limit and high limit alarm processing can be disabled. In the menu bar, select Edit-Add Alarm Disable. The corresponding module (box) will appear on screen. Make connections as described earlier under *Configuration Tools - Making Connections*.

Note: The Alarm Disable feature is sometimes referred to as Auto Shutdown in the BAS.

### **Via the SX Tool**

Under Analog Inputs, the alarm limits differential is adjustable with Item ADFn (RI.06). The high limit is at Item HIAAn (RI.03), the low limit is at Item LOAn (RI.04).

The low and high limit alarm processing can be disabled by making a logical connection to Item ALD@ - Alarm Disable Condition Source (General Module RI.31).

### **For Both SX and GX**

When the logic signal connected to ALD@ or Alarm Disable Condition Source is true (1), alarm states on analog inputs will be frozen until the logical signal returns to false (0). (Alarm states on analog inputs to XT modules are not frozen by the ALD@ connection.)

### **AI: Filter Time Constant**

The Filter Time Constant  $T_s$  (seconds) is used to filter out any cyclic instability in the analog input signals. The calculations are:

$$FV_t = FV_{t-1} + [1/(1 + T_s)] * (AI_t - FV_{t-1})$$

Where:  $FV_t$  = Filtered Analog Value at current time  
 $FV_{t-1}$  = Filtered Analog Value at previous poll  
 $AI_t$  = Actual Analog Value at current time

### **Via the GX Tool**

Select AIn. Then select Data in the module menu. At the Filter Constant (sec) field, enter a number within the recommended range 0 to 10.

### **Via the SX Tool**

Under Analog Inputs, the Filter Time Constant is selected at Item FTCn (RI.05).

### **AI Notes**

1. You can read the AI values, and read and modify the alarm limit values using the DX front panel. See *Display Panel and Keypads* in the *DX-9100 Extended Digital Controller Technical Bulletin (LIT-6364020)* in *FAN 636.4* or *1628.4*.

2. The alarm condition of one or more analog inputs is also indicated by an LED (AL) on the front panel. If the LED is steady, the current AI is in alarm; if flashing, another AI is in alarm.
3. Using the SX Tool, analog input values can be read at Analog Inputs Item AIn (RI.07), and the percent of range value can be read at Item AI%n (RI.08). The value as an ADC count can be read at Item ADCn (RI.09).
4. Using the SX Tool, analog input alarm statuses can be read at General Module Item AIS (RI.07), or at Analog Input Item AISTn (RI.10), where bits X1 and X2 indicate the high and low alarm conditions, respectively.
5. Under Analog Inputs, the analog Item AISTn (RI.10), bits X3 and X4, indicate an input over-range (input about 2% of range above HR) condition and an input under-range (input about 2% of range below LR) condition, respectively. (This information is available on the SX Tool only.)
6. Calibration coefficients for active and passive analog inputs are stored in the EEPROM of the DX. See the *Calibration Values* section further in this document.

## GX Labels

### **Source Points (Outputs)**

|      |  |
|------|--|
| AIn  | The current value of the analog input.   |
| AI%n | The current value of the analog input in percent (%) of range.   |
| AIHn | A 1 if the analog input is above its high limit and not below the high limit - limit differential.   |
| AILn | A 1 if the analog input is below the low limit and not above the low limit + limit differential.   |
| OVRn | A 1 when the value of an <i>active analog input</i> is more than about 2% above its <i>high</i> range (overrange condition), or a <i>passive analog input</i> is open circuited. |
| UNRn | A 1 when the value of an active analog input is more than about 2% below its low range (underrange condition), or a passive analog input is short circuited.                     |

### **Destination Points (Inputs)**

None.

Note: The following destination point is applicable to all analog inputs:

|       |  |
|-------|--|
| ALDS@ | The connection to disable alarm processing on analog inputs AI1 - AI8. |
|-------|--|



---

## Digital Input Configuration

The DX-9100 Controller can accept up to eight digital inputs, which will be considered active when driven to a common digital ground by an external volt-free contact. The DI is defined and configured by the following parameters:

- User Name and Description (GX only)
- Prescaler

The digital input transitions are counted as follows:

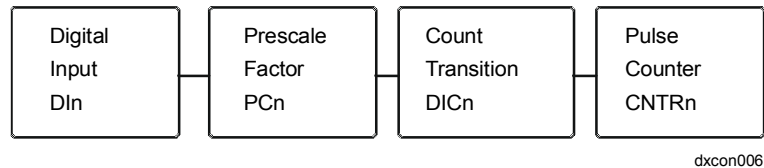

**Figure 6: Digital Input Transitions**

The Pulse Counter (CNTRn) counts all state transitions of the bit-Item DICn. A state transition at DICn occurs when the number of transitions from 1 to 0 of DIn Digital Input equals the value of the Prescaler Factor (PCn). For example, if PCn is equal to 1, then every 1 to 0 state transition at the DI will add 1 to CNTRn. If equal to 3, then three changes from 1 to 0 will add 1 to CNTRn. The maximum transition rate of DIn is 10 pulses per second (minimum 50 ms On and 50 ms Off).

### DI: User Name, Description, Prescaler

#### ***Via the GX Tool***

Select DIn. Then select Data in the module menu.

At the User Name field, enter the name, which can have a maximum of eight characters.

At the Description field, enter the descriptive text, which can have a maximum of 24 characters.

At the Prescaler (counts) field, enter a number between 1 and 255.

#### ***Via the SX Tool***

Under General Module, enter the prescaler for each digital input at Items PC1 (RI.22) to PC8 (RI.29).

### DI Notes

1. You can read the DI's status and counter values using the DX front panel. See *Display Panel and Keypads* in the *DX-9100 Extended Digital Controller Technical Bulletin (LIT-6364020)* in *FAN 636.4* or *1628.4*.
2. On the SX Tool, the digital input status (DIn), the count transition status (DICn) and the pulse counter values can be read under General Module at the Items given in Figure 6.

## **GX Labels**

### **Source Points (Outputs)**

DIn The current status of the digital input.

DICn Toggles from 0 to 1 or 1 to 0 when the number of digital input transitions (counts) equals the prescaler.

### **Destination Points (Inputs)**

None.

---

## **Analog Output Configuration**

The DX-9100 Controller has two analog outputs (numbered 1 and 2), controlled by two analog output modules, and six digital (triac) outputs (numbered 3 to 8) controlled by six logic output modules. Versions 2 and 3 of the DX-9100 have an additional six analog outputs (numbered 9 to 14) controlled by six analog output modules.

The analog output module provides the interface between a 0-10 VDC or 0/4-20 mA hardware output and a numeric value scaled to a 0-100% range using a high and low range variable.

Each analog output is defined and configured by the following parameters:

- user name and description (GX Only)
- type of output
- numeric source
- increase/decrease source (if any)
- low and high ranges
- forcing mode and level
- hold or auto on power up
- output limits, enable limits

## **AO: Output Type**

### **Via the GX Tool**

Select AOn. Then select Data in the module menu. At the field User Name, enter the name.

At the Description field, enter the description.

Then enter the output code:

0 = Disabled

1 = 0 to 10 VDC

2 = 0 to 20 mA (not available for Outputs 11-14)

3 = 4 to 20 mA (not available for Output 11-14)

### ***Via the SX Tool***

Under Output Modules, the output type can be configured in Item AOTn (RI.00). To define the output signal set the bits as follows:

X2 X1 = 00 Output Disabled

X2 X1 = 01 Output 0-10 V

X2 X1 = 10 Output 0-20 mA (not available for Outputs 11-14)

X2 X1 = 11 Output 4-20 mA (not available for Outputs 11-14)

### **AO: Source**

This defines the source of the numeric control signal that drives the output module. The output module can, alternatively, have two logic sources: the source of the increase signal and the source of the decrease signal. The rate of increase or decrease is fixed at 1% per second.

### ***Via the GX Tool***

Expand both source and AOn modules. Place the mouse on the source point. Hold down the left mouse button and drag the cursor to the center of AO@. The connection will be made when the mouse button is released.

If logic variables (Increase/Decrease) are used as a source to drive the analog output, then the source module and AOn module must be expanded as described above. Place the cursor on the logic source point. Press the mouse button and while keeping it pressed, drag the cursor to INC@ in the AOn module. Release the mouse button to make the connection. Repeat the same procedure for the DEC@ connection.

### ***Via the SX Tool***

Under Output Modules, Item AO@n (RI.01) defines the source of the numeric control signal. Alternatively, the source of the increase signal is defined in Item INC@n (RI.10), and the source of the decrease signal is defined in Item DEC@n (RI.11).

### **AO: Forcing Mode and Level**

This defines the source of a logic variable that forces the Analog Output to a forcing level between 0 and 100%. When the logic source is 1, the AO will be forced to the % entered in Forcing Level. When the logic source is 0, the AO will be commanded to position via the source point.

Note: If a PID is connected to the AO and the AO is forced, the PID will experience force-back, which means the PID is also in Hold mode at this time and its output is forced to the value of the analog output.

### ***Via the GX Tool***

Select AOn. Then select Data in the module menu. At the Forcing Level (%) = field, enter a number between 0 and 100%.

Double-click on AOn to expand the module. Double-click on the source module. Place the cursor on the logic source point. Press the mouse button and while keeping it pressed, drag the cursor to AOF@. Release the mouse button to make the connection.

### ***Via the SX Tool***

Under Output Modules, Item AOF@n (RI.02) defines the source of a logic variable that forces the output to the forcing level, which is defined in Item OFLn (RI.05).

## **AO: Hold or Auto On Power Up**

Upon power restoration, the AO can optionally be forced to a Hold (Manual) or Auto (Hold reset) condition, irrespective of the Hold condition before the power failure and overriding the Initialization on Power Up setting for the controller and overrides sent from the front panel or BAS.

### ***Via the GX Tool***

Select AIn. Then select Data in the module menu. Then enter 1 for the appropriate power up condition, if required:

Hold on Power Up = (1 = Yes)

Auto on Power Up = (1 = Yes)

If both Hold and Auto are enabled, Hold has higher priority. If both are disabled, the current setting under the Initialization on Power Up field determines the output.

### ***Via the SX Tool***

Under Output Modules, set bits X7 and X8 of Item AOTn (RI.00) as follows:

bit X8 = 0 The Hold mode is not altered after a power failure.

bit X8 = 1 The Hold mode is set at power up to the status set in bit X7.

bit X7 = 0 The Hold mode is set to hold at power up if bit X8 is set.

bit X7 = 1 The Hold mode is reset (set to 0) at power up if bit X8 is set.

## AO: Range

The High Range Item (HRO) defines the level of the control source signal (AOn), which would correspond to an output of 100%.

The Low Range Item (LRO) defines the level of the control source signal (AOn), which would correspond to an output of 0%.

If  $LRO_n < AOn < HRO_n$        $OUT_n = 100 * (AOn - LRO_n) / (HRO_n - LRO_n) \%$

If  $AOn \leq LRO_n$                        $OUT_n = 0\% (0 \text{ V}, 0/4 \text{ mA})$

If  $AOn \geq HRO_n$                        $OUT_n = 100\% (10 \text{ V}, 20 \text{ mA})$

When the source point is equal to the high range, then the output will be at the maximum signal (10 V/20 mA). When the source point is equal to low range, then the output will be at the minimum signal (0V, 0/4 mA).

### ***Via the GX Tool***

Select AIn. Then select Data in the module menu. At the High Range and Low Range fields, enter the appropriate numbers within the range of the source signal:

High Range =

Low Range =

### ***Via the SX Tool***

Under Output Modules, set the High Range at Item HROn (RI.03) and the Low Range at Item LRO (RI.04).

## AO: Output Limits, Enable Limits

The output high limit defines the maximum output in percent. The output low limit defines the minimum output in percent. These limits are enabled by a logic connection and are only operative when the logic source is at 1.

When the limits are enabled:

If  $OUT_n > HLO_n$

$OUT_n = HLO_n$

If  $OUT_n < LLO_n$

$OUT_n = LLO_n$

### **Via the GX Tool**

Select AOn. Then select Data in the module menu. At the High Limit % and Low Limit % fields, enter the desired number (0-100%). For Enable Limits, expand both source and AOn modules. Position the cursor on the source point. Press the mouse button, and while keeping it pressed, drag the cursor to ENL@. Release the mouse button to make the connection.

### **Via the SX Tool**

Under Output Modules, set the following:

High Limit on Output = Item HLOn (RI.08)

Low Limit on Output = Item LLOn (RI.09)

The limits are enabled by a logic connection to Item ENL@n (RI.12).

### **AO Notes**

1. The AO can be read and overridden (placed in hold) from the DX front panel. See *Display Panel and Keypads* in the *DX-9100 Extended Digital Controller Technical Bulletin* (LIT-6364020) in *FAN 636.4* or *1628.4*.
2. On the SX Tool, the analog output values can be read in percent at Item OUTn (RI.06) and can be modified when the module is in Hold mode.
3. On the SX Tool, Analog output control and status can be seen at Item AOCn (RI.07) in the following bits:

|        |      |  |
|--------|------|--|
| X1 = 1 | OUn  | Output in Hold mode (Manual)                     |
| X2 = 1 | AOn  | Output at High Limit ... 100%                    |
| X3 = 1 | ALn  | Output at Low Limit ... 0%                       |
| X4 = 1 | AOFn | Output is Forced                                 |
| X6 = 1 | OULn | Output is Locked (Both INC@n and DEC@n are true) |
4. The analog output module can be set in Hold on the DX front panel or by the PLC, the SX Tool, a BAS, or by configuration on power up.

## **GX Labels**

### ***Source Points (Outputs)***

- AOFn** A 1 when an analog output (AO) is being externally forced.
- AOHn** A 1 when the analog output is equal to or above its high range.
- AOLn** A 1 when the analog output is equal to or below its low range.
- OUHn** A 1 when an analog or digital output is in Hold mode from either the DX front panel or BAS.
- OUTn** The value of the analog output (including PAT or DAT).

### ***Destination Points (Inputs)***

- AO@** The numeric connection to control an analog output.
- AOF@** The connection to force an analog output to a specified value.
- DEC@** The connection to decrement an analog type output, PAT/DAT digital type output or a sequencer module. While connection is a logic 1, the output will decrease at a rate dependent on the type of module.
- ENL@** The connection to enable output limits of an analog type output (PAT and DAT included).
- INC@** The connection to increment an analog type output, PAT/DAT digital type output or a sequencer module. While connection is a logic 1, the output will increase at a rate dependent on the type of module.

---

## **Digital Output Configuration**

The DX-9100 Controller has six digital output modules that are used to control six triacs. The digital output module provides the interface between a triac output and a numeric or logic variable. The modules can be programmed as one of five main output types.

Some of the output types drive two consecutive outputs. In that case the second, consecutive module will be disabled, as it cannot be executed.

For each digital output module one must define:

- the type of output
- User Name and Description

For digital output modules defined as PAT or DAT, you must also define:

- the source
- increase/decrease source (if any)
- the source of the feedback (if any) (PAT only)
- the low and high ranges
- the Forcing Mode and Level
- Hold or Auto on power up
- output limits, enable limits source (if any)
- the PAT full stroke time or DAT cycle
- the PAT deadband or DAT minimum on/off time

The types of configurations are described next, followed by the steps needed to configure the outputs.

### **PAT Position Adjust Type**

The PAT output type uses a pair of triacs and a numeric source. Position Adjust Type control is also known as incremental control. Using High Range and Low Range parameters, the value of the numerical source is normalized to a 0-100% value and is used as the required position for the output.

The PAT output may have a physical feedback value signal (0-100%) from an analog input or other numerical variable. In this configuration the output module will drive the first triac of the pair (increase or up signal) as long as the feedback value is less than the required position. It will drive the second triac of the pair (decrease or down signal) as long as the feedback value is greater than the required position. A deadband (in percent) is specified to avoid unnecessary cycling of the triac outputs when the feedback signal is approaching the required position, and compensates for any hysteresis or mechanical tolerances in the driven device.



When the PAT output does not have a physical feedback signal, it operates on the amount of change in the required position. To synchronize the PAT output module to the driven device, whenever the required position goes to 100%, the first triac (increase) will be switched on for the calculated time and will remain on for the specified Full Stroke Time of the driven device. Whenever the required position goes to 0%, the second triac (decrease) will be switched on for the calculated time and will remain on for the specified Full Stroke Time. If the required position remains at 100% or 0%, the appropriate triac will be switched on for the Full Stroke Time every two hours to ensure that the driven device remains at its end position over an extended period of time. For all other values of the required position, the PAT output module calculates the appropriate increase or decrease time, based on the Full Stroke Time, to bring the driven device from the last required position to the current required position, and switches the appropriate triac on for this time. The triac will not be switched if the change in the required position is less than the specified deadband. The calculation of the PAT time is performed on each processor cycle (every second), and the minimum triac on time is 100 msec.

Note: The DX display panel shows the required position value (OUTn) for the digital output module associated with the first triac output.

### **DAT Duration Adjust Type**

The DAT output type provides a time-based duty cycle output that is proportional to the value of a numeric source. Using High Range and Low Range parameters, the value of the numerical source is normalized to a 0-100% value as is used as the required duty cycle. For example, with a 25% duty cycle and a DAT cycle time of 600 seconds, the triac output will be switched on for 150 seconds and off for 450 seconds. At 0% required duty cycle the triac is always off, and at 100% duty cycle the triac is always on. To avoid short on pulses when the required duty cycle is close to 0%, or short off pulses when the required duty cycle is close to 100%, a minimum on/off time may be specified (in percent of duty cycle). For applications with a short DAT duty cycle (< 10 sec) it should be noted that the absolute minimum on or off time of the output triac is 100 msec. The DAT will always complete a calculated on or off period before recalculating the next off or on time from the current value of the numeric source. The DAT recalculates after its on time and after its off time so a full on/off cycle may not equal the repetition cycle if the numeric source is changing.

### **On/Off**

This type provides a single maintained on/off triac output. It can be driven by either a logic source or numeric source where a positive value would equal an on and a zero or negative value would equal an off.

## STA/STO

This type uses a pair of triac outputs and requires a logic source. A start command (logic source changes from 0 to 1) sends a one second pulse to the first triac of the pair and a stop command (logic source changes from 1 to 0) sends a one second pulse to the second triac.

Note: The DX display panel shows the status of the logic source to the digital output module associated with the first triac output. This displayed status is also the last command (on or off) to the triac pair. The display does not indicate the actual triac status.

## PULSE

This type provides a single momentary triac output from a logic source. When the logic source becomes a 1, a one second pulse is sent to the triac. When the logic source changes to 0, a one second pulse is sent to the same triac.

---

### ***DO: Output Type***

#### **User Name and Description**

#### ***Via the GX Tool***

Double-click on DOn with the left mouse button. Then select one of the following: PAT, DAT, On/Off, STA/STO, or PULSE. Select DOn using the right mouse button. Then select Data in the module menu. Enter the user name and description in the respective fields.

#### ***Via the SX Tool***

For each digital output module the type of output can be selected with the following bits under Output Modules in Item DOTn (RI.00):

- |                |  |
|----------------|--|
| X3 X2 X1 = 000 | Output disabled or paired.   |
| X3 X2 X1 = 001 | On/Off - driven from a logic source.   |
| X3 X2 X1 = 010 | On/Off - driven from a numeric source ( $\leq 0 = \text{off}$ , $> 0 = \text{on}$ ).   |
| X3 X2 X1 = 011 | DAT (Duration Adjust Type) output, or time-based proportional duty cycle, driven from a numeric source.  |
| X3 X2 X1 = 100 | PAT without feedback: combination of two outputs, driven from a numeric source.<br><br>Note: The next output is automatically taken from the next Digital Output Module in numerical sequence. |
| X3 X2 X1 = 101 | PAT with Feedback: combination of two outputs, driven from a numeric source with an associated feedback connection.  |

- X3 X2 X1 = 110 Start/Stop: combination of two outputs driven from a logic source. This module gives the start command, and the next digital output (in numerical sequence) gives the stop command. Each triac switches on for one second.
- X3 X2 X1 = 111 Pulse Type: the output generates a one second pulse for each state transition of a logic source.

## **DO: Source**

This defines the source of the signal that will drive the output module. PAT and DAT output modules, alternatively to one numeric source, can have two logic sources: the source of the increase signal and the source of the decrease signal. The rate of increase or decrease for PAT type outputs is derived from the full stroke time. For DAT type outputs the rate is 1% per second.

### ***Via the GX Tool***

Expand both source and DOn modules. Position the cursor on the source point. Press the mouse button, and while keeping it pressed, drag the cursor to DOn@. Release the mouse button to make the connection.

Alternatively, for PAT and DAT modules, you can select sources for increase and decrease. Connections are made in the usual way between the increase source point and INC@, and between the decrease source point and DEC@ in the DOn module.

### ***Via the SX Tool***

Under Output Modules, the signal source is defined by Item DO@n (RI.01). PAT and DAT output modules can, alternatively, have two logic sources. The source of the increase signal is defined in Item INC@n (RI.13), and the source of the decrease signal is defined in Item DEC@n (RI.14).

## **DO: Feedback for PAT**

This defines the source of the analog feedback (0-100%) that is needed for the PAT with feedback type module.

### ***Via the GX Tool***

Expand the source and destination modules. Position the cursor on the source point. Press the mouse button, and while keeping it pressed, drag the cursor to FB@. Release the mouse button to make the connection.

### ***Via the SX Tool***

Under Output Modules, Item FB@n (RI.02) defines the source of the analog feedback.

**DO: Range  
(PAT or DAT)**

The High Range (HRO) defines the level of the control numeric source signal, which will correspond to the maximum output of 100%.

The Low Range (LRO) defines the level of the numeric control source signal, which will correspond to the minimum output of 0%.

The requested output is scaled to obtain:

$$\text{OUT}_n = 100 * (\text{DO}_n - \text{LRO}_n) / (\text{HRO}_n - \text{LRO}_n) \%$$

Where  $\text{DO}_n$  is the value of the control signal to the module (source value).

***Via the GX Tool***

Select  $\text{DO}_n$ . Then select Data in the module menu. At the High Range and Low Range fields, enter the desired numbers within the range of the source control signal.

***Via the SX Tool***

Under Output Modules, set the following:

High Range at Item  $\text{HRO}_n$  (RI.04)

Low Range at Item  $\text{LRO}_n$  (RI.05)

**DO: Forcing  
Mode and Level  
(PAT or DAT)**

This defines the source of a logic signal that forces the logic module output to a forcing level. When the logic connection is a 1, the output will go to a forced level; when 0, the output will go to normal control.

***Via the GX Tool***

Select  $\text{DO}_n$ . Then select Data in the module menu. At the Forcing Level field, enter a number from 0 to 100%.

Expand the source and destination modules. Position the cursor on the logic source point. Press the mouse button, and while keeping it pressed, drag the cursor to  $\text{DOF}@$ . Release the mouse button to make the connection.

***Via the SX Tool***

Under Output Modules, Item  $\text{DOF}@_n$  (RI.03) defines the source; Item  $\text{OFL}_n$  (RI.10) defines the forcing level.

**DO: Hold or Auto  
On Power Up  
(PAT or DAT)**

Upon power restoration, the DO can optionally be forced to a Hold or Auto (Hold reset) condition, irrespective of the Hold condition before the power failure and overriding the Initialization on Power Up setting for the controller.

### ***Via the GX Tool***

Select **DOn**. Then select **Data** in the module menu. Then enter 1 for the appropriate power up condition, if required:

Hold on Power up = (1 = Yes)

Auto on Power up = (1 = Yes)

If both Hold and Auto are enabled, Hold takes priority. If both are disabled, the current setting under the Initialization on Power Up field determines the output.

### ***Via the SX Tool***

Under Output Modules, set bits X7 and X8 of Item DOTn (RI.00) as follows:

bit X8 = 0 The Hold mode is not altered after a power failure.

bit X8 = 1 The Hold mode is set at power up to the status set in bit X7.

bit X7 = 0 The Hold mode is set to hold at power up if bit X8 is set.

bit X7 = 1 The Hold mode is reset (set to 0) at power up if bit X8 is set.

### **DO: Output Limits (PAT with Feedback or DAT)**

The output high limit defines the maximum output in percent. The output low limit defines the minimum output in percent. These limits are enabled by a logic connection and are only operative when the logic source is as 1. When the limits are enabled:

If  $OUT_n > HLO_n$

$OUT_n = HLO_n$

If  $OUT_n < LLO_n$

$OUT_n = LLO_n$

### ***Via the GX Tool***

Select **DOn**. Then select **Data** in the module menu. At the High Range Limit % and Low Limit % fields, enter the desired numbers (0-100%).

Expand source and destinations modules. Position the cursor on the source point. Press the mouse button, and while keeping it pressed, drag the cursor to **ENLn@** in the destination module. Release the mouse button to make the connection.

### ***Via the SX Tool***

Under Output Modules, set the following:

High Limit on Output = Item HLOn (RI.08)

Low Limit on Output = Item LLOn (RI.09)

The limits are enabled by a logic connection to Item ENL@n (RI.15).

### **DO: PAT Full Stroke Time or DAT Cycle**

The full stroke time (in seconds) needs to be defined for PAT type modules. This is the time it takes the electromechanical actuator to drive the controlled device from fully open to fully closed or vice versa.

The DAT cycle (in seconds) also needs to be defined. This is the duration adjust time proportion base for a DAT type output.

### ***Via the GX Tool***

For PAT, select DOn. Then select Data in the module menu. At the Stroke Time (sec) field, enter the electro-mechanical actuator stroke time.

For DAT, select DOn. Then select Data in the module menu. At the Repetition Cycle (sec) field, enter the cycle.

### ***Via the SX Tool***

Under Output Modules, Item FSTn (RI.06) defines the full stroke time (in seconds) for PAT type modules.

The same Item defines the DAT cycle (in seconds).

### **DO: PAT Deadband**

The PAT deadband is the change in output value required to initiate triac switching in a PAT type output.

### **DAT Minimum On/Off Time**

The DAT minimum On/Off time defines in percent of cycle the shortest on period when the required output approaches 0%, and the shortest off period when the required output approaches 100%.

### ***Via the GX Tool***

For PAT, select DOn. Then select Data in the module menu. At the Deadband field, enter the desired number (normally a whole number between 0 and 5%).

For DAT, select DOn. Then select Data in the module menu. At the Minimum On/Off (%) field, enter the desired number in percentage of repetition cycle (normally between 0 and 5%).

### **Via the SX Tool**

Under Output Modules, Item DBn (RI.07) defines the PAT deadband.

The same Item defines the DAT Minimum On/Off in % of output.

### **DO Notes**

1. The DOs can be read and overridden (put in hold) from the DX front panel. See *Display Panel and Keypads* in the *DX-9100 Extended Digital Controller Technical Bulletin (LIT-6364020)* in *FAN 636.4* or *1628.4*.
2. On the SX Tool, the output values can be read in percent at Output Modules, Item OUTn (RI.11). For PAT and DAT type modules the range is 0-100%. The other types have an output of 0 (off) or 100 (on) percent.
3. Digital Output Control and Status can be seen at Item DOCn (RI.12) on the SX Tool in the following bits:

|        |      |                               |
|--------|------|-------------------------------|
| X1 = 1 | OUn  | Output in Hold mode (manual)  |
| X2 = 1 | DOHn | Output at High Limit ... 100% |
| X3 = 1 | DOLn | Output at Low Limit ... 0%    |
| X4 = 1 | DOFn | Output is Forced              |
| X5 = 1 | AFBn | Incorrect Feedback            |

(The incorrect feedback bit is set whenever one of the PAT output triacs is switched on and the feedback signal does not change within five seconds.)

|        |      |  |
|--------|------|--|
| X6 = 1 | OULn | Output is Locked (both INC@n and DEC@n are true) |
|--------|------|--|
4. The triac output status can be read on the SX Tool under General Module, at Item TOS (RI.05).
5. The digital output module can be set in Hold (Manual) on the DX front panel or by the PLC, the SX Tool, a BAS, or by configuration on power up.

## GX Labels

### Source Points (Outputs)

|                  |   |
|------------------|---|
| AFB              | A 1 when the DO PAT associated feedback value is not responding to changes in the DO PAT command value. |
| DO <sub>n</sub>  | The status of the digital output.   |
| DOF <sub>n</sub> | A 1 when the digital output PAT or DAT is being externally forced.                                      |
| DOH <sub>n</sub> | A 1 when the digital output PAT or DAT is at its defined high limit.                                    |
| DOL <sub>n</sub> | A 1 when the digital output PAT or DAT is at its defined low limit.                                     |
| OUH <sub>n</sub> | A 1 when an analog or digital output is in Hold mode from either the DX front panel or BAS.             |
| OUT <sub>n</sub> | The value of the analog output (including PAT or DAT).  |

### Destination Points (Inputs)

|      |   |
|------|---|
| DEC@ | The connection to decrement an analog type output, PAT/DAT digital type output or a sequencer module. While connection is a logic 1, the output will <i>decrease</i> at a rate dependent on the type of module. |
| DO@  | The connection to control a digital output.   |
| DOF@ | The connection for forcing a digital output to a specified value.   |
| ENL@ | The connection to enable output limits of an analog type output (PAT and DAT included).   |
| FB@  | The connection to the <i>feedback</i> of a PAT. Usually a signal from a potentiometer on the controlled device.   |
| INC@ | The connection to increment an analog type output, PAT/DAT digital type output or a sequencer module. While connection is a logic 1, the output will <i>increase</i> at a rate dependent on the type of module. |

---

## Constants and Result Status

### Analog Constants

There are eight Analog Constants in the DX-9100. The value of each constant can be set by the SX-9120 Service Module, GX-9100 Configuration software, or BAS, used in an analog connection to provide a constant analog value for a programmable function module or output module. In a Version 2 or 3 controller, the analog constants may also be set at the DX front display panel. These values are not located in EEPROM and therefore can be written to via the BAS.



### ***Via the GX Tool***

Select PM from the toolbar, and then Analog Constants. An ACO module (box) appears. Place it where desired on screen. Select ACO. Then select Data in the module menu. Enter the values as required. Select OK to reconfirm entries, or Cancel to discard them.

### ***Via the SX Tool***

Under General Module, set Items AC01 - 8 (RI. 34-41).

## **Digital Constants**

There are 32 Digital Constants in the DX-9100. The value of each constant can be set by the SX-9120 Service Module, GX-9100 Graphic Configuration Tool, or BAS, and used in a logic connection to provide a logic value for a programmable function module, output module or PLC module. In a Version 2 controller, the digital constants may also be set at the front display panel. These values are not located in EEPROM and therefore can be written to via the BAS.

### ***Via the GX Tool***

Select PM from the toolbar, and then Digital Constants. A DCO module (box) appears. Place it where desired on screen. Select DCO. Then select Data in the module menu. Enter the values as required. Select OK to reconfirm entries, or Cancel to discard them.

### ***Via the SX Tool***

Under General Module, set Items LCOS1 and LCOS2 (RI.10, RI.11). LCOS1 is DCO1-16. LCOS2 is DCO17-32.

## **Logic Result Status:**

There are 64 Logic Result Status variables in the DX-9100 (in Version 1.0, only 32 are available). The value of each status variable can be set by the OUT, OUTNOT, SET, or RST instruction of the PLC module, and can be used in a logic connection to provide a logic value for a programmable function module, output module, or PLC module. The variables can also be used to transmit status conditions to a BAS. These values are read only and can only be changed by PLC execution.

### ***Via GX Tool***

Select PM from the toolbar, and then select LRS1-32 (or LRS33-64). A module (box) will appear. Place it as desired on screen. Connections can be made in the usual way. (See *Configuration Tools - Making Connections* earlier in this document.)

### **Via SX Tool**

Under General Module, the logic result status variables can be read at Items LRST1, LRST2, LRST3, and LRST4 (RI.08, RI.09, RI.44, RI.45). LRST1 is LRS1-16. LRST2 is LRS17-32. LRST3 is LRS33-48. LRST4 is LRS 49-64.

### **Analog Constants, Digital Constants Note**

The analog and digital constants can be read and modified (Versions 2 and 3) from the DX front panel. See *Display Panel and Keypads* in the *DX-9100 Extended Digital Controller Technical Bulletin (LIT-6364020)* in *FAN 636.4* or *1628.4*.

### **GX Labels**

#### **Source Points (Outputs)**

- ACOn The current value of an analog constant set by a supervisory system, the GX Tool, SX Tool, or on the DX front panel.
- DCOn The current value of a digital constant set by a supervisory system, the GX Tool, SX Tool, or on the DX front panel.
- LRSn The logic result status of an OUT, OUTNOT, SET, or RST statement in a PLC.

#### **Destinations Points**

None.

---

### **Extension Module Configuration**

Note: The XTM-905 extension module may be connected to DX controllers, Versions 1.4, 2.3, 3.3, or later, and is configured, monitored and controlled using the same Items as the XT-9100 extension module.

The parameters for the configuration of inputs and outputs in extension modules reside partly in the DX-9100 Controller and partly in the XT-9100 or XTM-905 Extension Module.

The parameters required by the DX-9100 Controller are described in detail in this manual. For details on the extension modules, refer to the *XT-9100 Technical Bulletin (LIT-6364040)* and the *XT-9100 Configuration Guide (LIT-6364050)*, or the *XTM-905 Extension Module, XPx-xxx Expansion Modules Technical Bulletin (LIT-6364210)*.

Each extension module is defined by the following parameters:

- input and output types, and XT/XTM layout map
- extension module address
- sources (connections) for outputs
- high and low ranges for analog outputs
- high and low limits for analog inputs

### **XT/XTM: Type, Mode, and Map**

#### ***Via the GX Tool***

The I/O type and map details are automatically generated by the GX-9100 Graphic Configuration Software when all I/O data for extension modules has been entered, and can be downloaded to the DX-9100 and also to the extension modules when connected to the DX-9100 via the XT Bus.

Select **PM** from the toolbar, then **XT or XTM** and the appropriate input/output type. A module (box) appears. Place it where desired on screen. The inputs and outputs for the XT/XTM appear on the left and right sides of the screen, respectively. Configure each input/output as appropriate (similarly to DX I/O).

A module labeled XT<sub>n</sub> or XTM<sub>n</sub> will be for the points in the first XP connected to that XT or XTM. If a second XP is connected, the EXP module must be defined immediately following the first XT or XTM. An EXP<sub>n</sub> is always an expansion to the XT<sub>n-1</sub> or XTM<sub>n-1</sub> module.

### ***Via the SX Tool***

The I/O types and map are configured in Extension Module Items, under **XT Modules** at **XTnIOMAP** (RI.00), **XTnIOTYP** (RI.01), and **XTnIOMOD** (RI.02).

The I/O map (XTnIOMAP) defines which inputs/outputs (in pairs) on the extension module are used and hence monitored or controlled by the DX-9100. Eight extension modules can be defined, each with eight used points, which normally reside on the first Expansion Module XP1 (I/O Points 1-8), defined in bits X1-4.

When an extension module has a second expansion module, XP2, with a further eight points, these points must be defined in bits X5-8. However, in this case, the next extension module in numerical sequence cannot be configured because the DX-9100 will use the database area reserved for the I/O points of the next extension module for the points of XP2 in this extension module. For example, if Extension Module 1 (XT1 or XTM1) has only one expansion module, XP1, all the points of XP2 will be declared as not used (bits X5-8 set to 0) and Extension Module 2 can be configured. However if Extension Module 1 has two expansion modules and some points in XP2 are declared as used (one or more bits of X5-8 set to 1), then Extension Module 2 (XT2 or XTM2) cannot be configured and all its points must be declared as not used (bits X1-8 set to 0). The I/O type (XTnIOTYP) defines which inputs/outputs (in pairs) are analog and which are digital. As the points on XP2 (if used) must be digital, only bits X1-4 can be configured.

The I/O mode (XTnIOMOD) defines points as input or output (in pairs). Only those points declared as used in Item XTnIOMAP will be monitored or controlled.

The combination of data in the Items XTnIOMAP, XTnIOTYP, and XTnIOMOD completely defines the configuration of an extension module. An identical set of data must be entered into the Item database in the XT-9100 or XTM-905 extension module, so that when the DX-9100 and XT/XTM are connected and started up, the DX-9100 compares databases and only send commands to the extension module if the data is identical, thus avoiding incorrect control actions. If the databases are not identical, Item XTnST, bit X6 (XTnERR) will be set. If the physical hardware of the XT/XTM module does not correspond to the database, Item XTnST, bit X4 (XTnHARD) is set.

**XT/XTM:  
Address, User  
Name,  
Description**

The extension module *address* is set as an 8-bit integer (1-255). This address must also be set on the address switches of the extension module, and must be unique not only on the XT-Bus, but also on the N2 Bus (or Bus 91) to which the DX-9100 is connected. An extension module address of 0 is not permitted on the XT Bus.

***Via the GX Tool***

Select **XTn**. Then select **Data** in the module menu. Enter the user name and description in the window that appears. In the Hardware Address field, enter the address set on the XT-9100 or XTM-905 module (a number between 1 and 255).

***Via the SX Tool***

The extension module address is set under **XT Modules**, in Item **XTnADX** (RI.03).

**XT/XTM: Source**

Only output points require a source connection. For analog outputs the source must define a numeric variable, and for digital outputs the source must define a logic variable. Inputs and outputs appear on the left and right sides of the screen, respectively.

***Via the GX Tool***

Expand source and destination modules. Position the cursor on the source point. Press the mouse button, and while keeping it pressed, drag the cursor to the destination point. Release the mouse button to make the connection.

***Via the SX Tool***

The sources for the points declared as outputs in XP1 of XTn or XTMn are entered under XT Modules at Items **XTnI1@-8@** (RI.04-11). The sources for the points declared as outputs in XP2 of XTn (if used) are entered in Items **XT(n+1)I1@-8@** in the next extension module Item area (n+1). All points in this next module must already have been declared unused.

## XT/XTM: High and Low Ranges for Analog Outputs

For analog outputs, the Analog High Range (AHR) defines the level of the source control signal that will correspond to the maximum output at the extension module, and the Analog Low Range (ALR) defines the level of the source control signal that corresponds to the minimum output at the extension module.

The value of the output is defined as follows:

$$\text{If } XTnALR < XTnI < XTnAHR \quad XTnAO = \frac{100x (XTnI - XTnALR)}{(XTnAHR - XTnALR)}$$

If  $XTnI < XTnALR$                        $XTnAO = 0\%$

If  $XTnI > XTnAHR$                        $XTnAO = 100\%$

Where  $XTnI$  is the value for the source control signal.

### ***Via the GX Tool***

Select the XT analog output point module. Then select **Data** in the module menu. Enter appropriate values within the range of the source signal under both the **High Range** and **Low Range** fields:

High Range =

Low Range =

Also enter the appropriate value in the **Type of Output** field.

### ***Via the SX Tool***

Under **XT Modules**, set the following Items:

Analog High Range =        Items **XTnAHR1-8** (RI.12-26, evens)

Analog Low Range =        Items **XTnALR1-8** (RI.13-27, odds)

## XT/XTM: High and Low Limits for Analog Inputs

The high limit and the low limit define at which levels the analog input reading will generate an alarm for remote monitoring purposes or for internal use within the control sequences in the DX-9100.

These limits will be automatically downloaded to the extension module by the DX-9100.

### ***Via the GX Tool***

Select the XT analog input point module and choose **Active** or **Passive**. Then click the right mouse button to call up the module menu and select **Data**. In the window that appears, enter appropriate values under both the **High Limit** and **Low Limit** fields:

High Limit=

Low Limit =

### ***Via the SX Tool***

Under **XT Modules**, set the following Items:

High limit = Items **XTnHIA1-8** (RI.28-42, evens)

Low limit = Items **XTnLOA1-8** (RI.29-43, odds)

## **XT Bus Timing**

The timeout on the XT Bus for the response to a message is set according to whether XT-9100 or XTM-905 extension modules are connected.

### ***Via the GX Tool***

The timing is set automatically by the GX Tool.

### ***Via the SX Tool***

Under General Module, Item **DXS1** (RI.32) set the following bits:

X6X5 = 00    XT-9100 extension modules only

X6X5 = 01    XTM-905 extension modules (or both XT-9100 and XTM-905)

## **XT/XTM Notes**

1. XT/XTM analog input values can be read, and alarm limits read and modified from the DX front panel. See *Display Panel and Keypads* in the *DX-9100 Extended Digital Controller Technical Bulletin (LIT-6364020)* in *FAN 636.4* or *1628.4*.
2. On the SX Tool, analog input values can be read under **XT Modules** at Items **XTnAI1-8** (RI.45-52). Only those points configured as analog inputs will be active.
3. Analog outputs can be read and overridden (put in hold) at the DX front panel. See *Display Panel and Keypads* in the *DX-9100 Extended Digital Controller Technical Bulletin (LIT-6364020)* in *FAN 636.4* or *1628.4*.
4. On the SX Tool, analog output values can be read in percent under **XT Modules** at Items **XTnAO1-8** (RI.53-60). Only those points configured as analog outputs, and with the type of output defined, will be active.

5. On the SX Tool, the total pulse count of digital inputs on XP1 can be read and reset under **XT Modules** at Items **XTnCNT1-8** (RI.61-68). Only those points configured as digital inputs will show a correct value.
  6. Output hold control and status can be seen on the SX Tool under **XT Modules** at Items **XTnOUH1-8** (bits X1-8 of Item **XTnHDC** [RI.69]). Analog and digital outputs can be modified by a BAS when in Hold mode.
  7. XT/XTM digital outputs can be read and overridden (put in hold) from the DX front panel. See *Display Panel and Keypads* in the *DX-9100 Extended Digital Controller Technical Bulletin (LIT-6364020)* in *FAN 636.4* or *1628.4*.
  8. Digital output control and status can be seen on the SX Tool under **XT Modules** at Items **XTnDO1-8** (bits X1-8 of Item **XTnDO** [RI.70]). Only those points configured as digital outputs will be active.
  9. XT/XTM digital inputs can be read from the DX front panel. See *Display Panel and Keypads* in the *DX-9100 Extended Digital Controller Technical Bulletin (LIT-6364020)* in *FAN 636.4* or *1628.4*.
  10. Digital input status can be seen on the SX Tool under **XT Modules** at Items **XTnDI1-8** (bits X1-8 of Item **XTnDI** [RI.71]). Only those points configured as digital inputs will be active.
  11. Extension module alarm status from analog inputs can be seen on the SX Tool under **XT Modules** at Items **XTnAIH1-XTnAIL8** (bits X1-16 of Item **XTnAIS** [RI.44]).
- Note: The Alarm Disable connection, described under *AI: Alarm Limits*, does not disable XT module alarms. XT/XTM alarms are only indicated by the AL LED on the DX front panel when the XT/XTM is selected for display of analog values.



12. Extension module local status can be seen on the SX Tool under XT Modules at Item **XTnST** (RI.72) in the following bits:

|    |     |         |  |
|----|-----|---------|--|
| X1 | = 1 | XTnCOM  | XT/XTM module not answering (wrong address, bus line broken, bus line overload).   |
| X3 | = 1 | XTnMIS  | XT databases in DX and XT/XTM do not match.  |
| X4 | = 1 | XTnHARD | XT/XTM hardware failure (XT/XTM cannot find correct XPs; hardware missing or not responding).  |
| X5 | = 1 | XTnSEL  | XT/XTM selected on XT-Bus.   |
| X6 | = 1 | XTnERR  | XT/XTM configuration error XTnCOM = 1 or XTnMIS=1 or XTnHARD = 1 (Versions 1.4, 2.3, 3.3, or later)  |
| X7 | = 0 | XTnFAIL | XT/XTM digital outputs set to 0 on communication failure.  |
| X7 | = 1 |         | XT/XTM digital outputs hold current state on communication failure. Read from XT module. See <i>the XT-9100 Configuration Guide (LIT-6364050)</i> or the <i>XTM-905 Extension Module, XPx-xxx Expansion Modules Technical Bulletin (LIT-6364210)</i> . |
| X8 | = 1 | XTnPWR  | XT/XTM detected loss of power or loss of communication.  |

Item X8 is automatically reset by the DX-9100 Controller after a few seconds.

## GX Labels

### **Source Points (Outputs)**

|                |  |
|----------------|--|
| <b>XTnAIIn</b> | The current value of the analog input from the XT/XTM.   |
| <b>XTnAIHn</b> | A 1 if the analog input is above its <i>high</i> limit and not below the high limit - limit differential.  |
| <b>XTnAILn</b> | A 1 if the analog input is below the <i>low</i> limit and not above the low limit + limit differential.  |
| <b>XTnAOn</b>  | The value of the analog <i>output</i> to the XT/XTM.   |
| <b>XTnCOM</b>  | A 1 when the extension module is not communicating (wrong address, bus line broken, or bus line overload).   |
| <b>XTnDIIn</b> | The current status of the <i>digital input</i> from the XT/XTM.  |
| <b>XTnDOIn</b> | The status of the <i>digital output</i> to the XT/XTM.   |
| <b>XTnERR</b>  | A 1 when the XT database in the DX does not match the XT database in the XT/XTM module, or when XTnCOM is a 1, or when XTnHARD is a 1 (Versions 1.4, 2.3, 3.3, or later). (Combination of errors for XT/XTM module.) |
| <b>XTnFAIL</b> | The status of the <i>Fail</i> mode in the XT/XTM. A 0 indicates that outputs go to 0 on communication failure and a 1 indicates that the status of the outputs will be maintained.                                   |
| <b>XTnHARD</b> | A 1 when the expansion module is not connected or not responding (hardware fault), or a module type does not match what was configured (for example, when an XP-9102 is configured and an XP-9103 is connected).     |
| <b>XTnOUHn</b> | A 1 when an analog or digital <i>output</i> is in Hold mode from either the DX front panel or BAS.   |
| <b>XTnPWR</b>  | A 1 when the <i>extension module</i> detects a loss of power or loss of communication. The DX will reset this after a few seconds.   |

### **Destination Points (Inputs)**

- AO@** The numeric connection to control an analog output.
- DO@** The connection to control a digital output.

---

**Network  
Analog Input  
Configuration  
(Version 3  
Only)**

The controller has 16 network analog input modules, each contains a numerical value received from an analog output in another controller on the same LONWORKS N2 Bus. These inputs can be used in the configuration in the same way as physical analog inputs. The source of the analog data is defined in the transmitting controller.

**User Tag Name  
and Type**

For each network analog input module one must define:

- User Tag Name and Description
- Network Analog Input Units (SX Only)

**Via the GX Tool**

Select **PM** from the toolbar, then **Network Analog Input**, and place the NAI on the screen. Select **NAIn** and **Data**. Enter the User Name and Description in the Data Window. The Units number is automatically set by the GX Tool.

**Via the SX Tool**

To configure a network analog input using the SX Tool, it is necessary to enter the units of the NAI in Item NAIinDIM (RI.18 to RI.33) under **NETWORK** (Key 8), **INPUT MODULES**, and 2 (**NETWORK AI MOD**). There is only one unit used by the DX-912x, which is number 55. It is also necessary to change Item NAIN (RI.04) under **NETWORK** and **GENERAL MODULE** when the first NAI is defined. This Item must be set to 1 if any NAIs are used in the configuration. These Items are automatically set by the GX Tool when the NAI is created.

**NAI Notes**

1. On the SX Tool the numeric value of the network analog inputs can be read at Items NAIin (RI.01 to RI.16) under **NETWORK** and **INPUT MODULES**.
2. On the SX Tool the Reliability Status of each analog input module can be seen on bits X1 to X16 at Item NAISTA (RI.17). These status indications can be used for backup control strategies in the case of a transmission failure by using the corresponding logic variables (NAIU1 to NAIU16) in the PLC. The Reliability Status will be set to 1 (Unreliable) when the DX Controller does not receive a new value over the network within a period of approximately 200 seconds.

## GX Labels

### **Source Points (Outputs)**

**NAIn** The current value of the Network Analog Input.

**NAIUn** A 1 when the analog input module is unreliable.

### **Destination Points (Inputs)**

None.

---

## **Network Digital Input Configuration (Version 3 Only)**

The controller has 8 network digital input modules, each contains 16 digital input status values received from a network digital output in another controller. Each of the 16 digital values in the digital input module can be used in the configuration in the same way as physical digital inputs. The source of the digital data is defined in the transmitting controller. Digital data is always transmitted in blocks of 16 values from 1 controller to another and the block cannot be split apart by the network. Not all 16 values need be used and within the controller the values can be used quite independently.

For each network digital input module one must define:

- User Tag Name and Description
- Network Digital Input Type (SX Only)

## **User Tag Name and Type**

### **Via the GX Tool**

Select **PM** from the toolbar, then **Network Digital Input**, and place the **NDIn** on the screen. Select **NDIn** and **Data**. Enter the User Name and Description in the Data Window. The Type number is automatically set by the GX Tool.

### **Via the SX Tool**

To configure a network digital input using the SX Tool, it is necessary to enter the type of the NDI in Item **NDInTYP** (RI.10 to RI.17) under **NETWORK** (Key 8), **INPUT MODULES**, and 1 (**NETWORK DI MOD.**). There is only one type used by the DX-9100, which is number 83. It is also necessary to change Item **NDIN** (RI.03) under **NETWORK** and **GENERAL MODULE** when the first NDI is defined. This Item must be set to 1 if any NDIs are used in the configuration. These Items are automatically set by the GX Tool when the NDI is created.

## NDI Notes

1. On the SX Tool the status values of the 16 digital inputs in each of the 8 network digital input modules can be read at bits X1 to X16 in Items NDIn (RI.01 to RI.8) under **NETWORK, INPUT MODULES**, and 1 (**NETWORK DI MOD**). The status values can be used in the configuration by connecting the corresponding logic variables NDIn-1 to NDIn-16.
2. On the SX Tool the Reliability Status of each digital input module can be seen on bits X1 to X8 at Item NDISTA (RI.9). These status indications can be used for backup control strategies in the case of a transmission failure by using the corresponding logic variables (NDIU1 to NDIU8) in the PLC. The Reliability Status will be set to 1 (Unreliable) when the DX controller does not receive a new value over the network within a period of approximately 200 seconds.

## GX Labels

### **Source Points (Outputs)**

**NDIn-m** The current value of the Network Digital Input.

**NDIUn** A 1 when the digital input module is unreliable.

### **Destination Points (Inputs)**

None.

---

## **Network Analog Output Configuration (Version 3 Only)**

The controller has 16 network analog output modules, each of which can transmit a numerical value to another controller on the same LONWORKS N2 Bus. The network analog output module receives its value from a connection to a numeric Item in the same controller. Each network analog output module, if configured, sends its value to up to 16 destinations which are, in fact, network analog input modules in other controllers on the same network. A maximum of 30 Version 3 controllers can be connected to one LONWORKS N2 Bus.

For each network analog output module one must define:

- User Tag Name and Description
- Network Analog Output Units (SX Only)
- up to 16 destinations (controller address and network input module number)
- source of the output value

**User Tag Name  
and Units**

***Via the GX Tool***

Select **PM**, then **Network Analog Output**, and place the NAO on the screen. Select **NAOn** and **Data**. Enter the User Name and Description in the Data Window. The Units number is automatically set by the GX Tool.

***Via the SX Tool***

When defining a network analog output module, it is necessary to enter the units of the NAO in Item **NAOnDIM** (RI.03) under **NETWORK** (Key 8), **OUTPUT MODULES**, and 2 (**NETWORK AO MODn**) (n = 1-16). There is only one unit used by the DX-9100, which is number 55. It is also necessary to change Item **NAON** (RI.02) under **NETWORK** and **GENERAL MODULE**. This Item must contain the number (0 to 16) of NAOs used in the configuration. These Items are automatically set by the GX Tool.

**NAO  
Destinations**

***Via the GX Tool***

Select **NAOn** and **Data**. In the field **Destination #1** enter a destination controller address (1-255) and a network input number (1-16) within the destination controller. Continue entering destinations as required up to the limit of 16. Only enter the address of controllers, which will be connected, to the same LONWORKS N2 Bus and use a network analog input number in a destination controller only once in the configuration.

***Via the SX Tool***

Destinations are configured in Items **NAOn>1** to **NAOn>16** (RI.04 to RI.19) under **NETWORK** (Key 8), **OUTPUT MODULES**, and 2 (**NETWORK AO MODn**) (n = 1-16). Enter the Destination Input number (NAI) (1-16) and Destination Controller Address (1-255). An Input number of 0 cancels the destination.

**NAO Source**

***Via GX Tool***

Expand **NAOn** to show the input **NAOnAO@**. Expand the source module with the desired output numeric Item and make the connection. The connection source may be seen in the NAO Data Window in the field **Source Point**.

***Via SX Tool***

Connections are defined in Items **NAOn@** (RI.20) under **NETWORK** (Key 8), **OUTPUT MODULES**, and 2 (**NETWORK AO MODn**) (n = 1-16). Enter a numeric Item address.

**NAO Note** On the SX Tool the numeric value of the network analog outputs can be read at Items NAOOnOUT (RI.01) under **NETWORK, OUTPUT MODULES**, and 2 (**NETWORK AO MODn**) (n = 1-16).

**GX Labels** **Source Points (Outputs)**

None.

**Destination Points (Inputs)**

**NAOn@** The numeric connection to control a Network Analog Output.

---

**Network Digital Output Configuration (Version 3 Only)**

The controller has 8 network digital output modules, each of which can transmit 16 digital status values to another controller on the same LONWORKS N2 Bus. Each of the 16 digital values in the digital output module receives its status from a logic variable in the same controller. Each network digital output module, if configured, sends its 16 digital status values as a block to up to 16 destinations which are, network digital input modules in other controllers on the same network. A maximum of 30 Version 3 controllers can be connected to one LONWORKS N2 Bus.

For each network digital output module one must define:

- User Tag Name and Description
- Network Digital Output Type (SX Only)
- up to 16 destinations (controller address and network input module number)
- sources of the 16 digital status values

**User Tag Name and Type**

**Via the GX Tool**

Select **PM**, then **Network Digital Output**, and place **NDO**n on the screen. Select **NDO**n and **Data**. Enter the User Name and Description in the Data Window. The Type number is automatically set by the GX Tool.

**Via the SX Tool**

When defining a network digital output module it is necessary to enter the type of NDO in Item **NDO**nTYP (RI.03) under **NETWORK** (Key 8), **OUTPUT MODULES**, and 1 (**NETWORK NDO MODn**) (n = 1-8). There is only one type used by the DX-9100, which is number 83. It is also necessary to change Item **NDO**n (RI.01) under **NETWORK** and **GENERAL MODULE**. This Item must contain the number (0-8) of NDOs used in the configuration. These Items are automatically set by the GX Tool.

**NDO  
Destinations**

***Via the GX Tool***

Select **NDO**n and **Data**. In the Data Window, select **Data-2** to go to page 2. In the field **Destination #1** enter a destination controller address (1-255) and a network input number (1 to 8) within the destination controller. Continue entering destinations as required up to the limit of 16. Only enter the address of controllers that will be connected to the same LONWORKS N2 Bus and use a network digital input number in a destination controller only once in the configuration. All 16 source points will be sent as a block to each destination defined.

***Via the SX Tool***

Destinations are configured in Items NDO>1 to NDO>16 (RI.04 to RI.19) under **NETWORK** (Key 8), **OUTPUT MODULES**, and 1 (**NETWORK DO MOD**n) (n = 1-8). Enter the Destination Input number (NDI) (1-8) and Destination Controller Address (1-255). An Input number of 0 cancels the destination.

**NDO Sources**

***Via GX Tool***

Expand NDO to show the inputs NDO-1@ to NDO-16@. Expand the source module with the desired output logic variable and make the connection. The connection sources may be seen in the NDO Data Window in the fields **Source bit #1** to **Source bit #16**.

***Via SX Tool***

Connections are defined in Items NDO-1@ to NDO-16@ (RI.20 to RI.35) under **NETWORK** (Key 8), **OUTPUT MODULES**, and 1 (**NETWORK DO MOD**n) (n = 1-8). Enter a logic variable index byte and bit number.

**NDO Note**

On the SX Tool, the 16 status values of each of the 8 network digital output modules can be read at Items NDO (RI.01) under **NETWORK**, **OUTPUT MODULES**, and 1 (**NETWORK DO MOD**n) (n = 1-8).

**GX Labels**

***Source Points (Outputs)***

None.

***Destination Points (Inputs)***

**NDO**-m@ The logic connection to control a Network Digital Output.



---

**Programmable  
Function  
Module  
Configuration**

The DX-9100 provides twelve programmable function modules that are sequentially executed each second. The module's function, inputs, and outputs depend on the algorithm assigned to it. The assignment is made by programming the module to correspond to the algorithm. Once the PM is defined to perform a specific function, the remaining entries of the module can be defined to achieve the desired output.

**Parameter Tags**

Each of the twelve programmable function modules has a set of generic parameters, each with a PM Tag.

Each of the available algorithms has a specific set of parameters, each with an algorithm tag (Alg. Tag).

When an algorithm is assigned to a programmable function module, a parameter has two tags:

- one PM Tag, which represents the generic function in the programmable function module
- one Alg. Tag, which represents the specific function of the parameter in the assigned algorithm

For example, the process variable connection in a PID control algorithm assigned to Programmable Function Module 1 has a generic tag, **PM111@**. In Algorithm 1 (PID controller) this same parameter has the tag **PV@**. Both tags are listed in the Item list for the algorithms; one as PM Tag and the other as Alg. Tag.

Note: In the GX Tool, algorithm tags are used exclusively. When mapping Items to a BAS, such as Metasys PM tags are used.

**Control  
Algorithm  
Configurations**

The DX-9100 provides four control algorithms:

- PID Controller
- On/Off Controller
- Heating/Cooling PID Controller (Dual PID)
- Heating/Cooling On/Off Controller (Dual On/Off)

Each of these algorithms can be used in any one of the twelve programmable function modules.

The algorithms have a number of different operating modes, which are a function of operating parameters and digital connections.

Each control module operates from its Working Setpoint (WSP), which is a resultant value calculated by the controller from the Reference Variable (RV), the Local Setpoint (LSP), the Remote Setpoint (RSP), the Standby Mode Bias (BSB), and the Off Mode Bias (BOF).

The algorithm then compares the Working Setpoint (WSP) with the Process Variable (PV) to generate an output (OCM).

- Comfort mode (or Occupied mode) is the working mode of the algorithm to obtain the desired control typical during occupancy. The output is calculated by the control algorithm using as working setpoint the value:

$$WSP = RV * (LSP + RSP)$$

This mode is active when both Standby and Off modes are disabled.

- When operating in Standby mode the controller setpoint may be reduced or increased when compared with the Comfort mode setpoint. The output is calculated by the control algorithm using as working setpoint the value:

$$WSP = RV * (LSP + RSP) + BSB$$

This mode is active when the standby module control connection is a Logic 1 and the Off mode is disabled.

The standby bias is a signed number, expressed in the same units as the PV.

- Off mode (Unoccupied mode) is similar to the Standby mode, but the setpoint may be further reduced or increased. The output is calculated by the control algorithm using the following function:

$$WSP = RV * (LSP + RSP) + BOF$$

This mode is active when the Off mode control connection is a Logic 1.

The off bias is a signed number, expressed in the same units as the PV.

In the Off mode, the output low limit of the controller is not used and the output can fall to 0.

If both Standby and Off modes are active, the control module uses the Off mode working setpoint.

### ***Via the GX Tool***

Before establishing the mode, you must first set the PM type to Control and then to the appropriate type. Click on **PM** in the toolbar, select **Control**, then **PID**, **On/Off**, **Dual PID**, or **Dual On/Off**, and position the module (box) on the screen. Select the module and then **Data** to call up the Data Window. Enter control parameters and modes.

To go to page 2, click on **Data 2**. At **Standby Bias (BSB)** or **Off mode Bias (BOF)**, enter a value to bias the WSP. For Dual PID or Dual On/Off modules, enter values for each loop at **Stdby Bias #1 (BSB1)**, **Off Bias #1 (BOF1)**, **Stdby Bias #2 (BSB2)**, and **Off Bias #2 (BOF2)**.

To define the mode connections, expand source and destination modules. Position the cursor on the source point. Press the mouse button, and while keeping it pressed, drag the cursor to SB@. Release the mouse button to make the connection. For Off mode, make a similar connection between the respective source point and OF@.

When the connected logic variable is in a 1 state, the value entered will be used to calculate the WSP of the module. The WSP is always the active setpoint of the module.

### ***Via the SX Tool***

Define the PM type under **Program Modules PMnTYP (RI.00)**:

- 1 = PID Controller
- 2 = On/Off
- 3 = Dual PID
- 4 = Dual On/Off

Then set the modes of operation under **Program Modules**:

**PMnOF@ (RI.14)** defines the Off mode control logic connection.

**PMnSB@ (RI.15)** defines the Standby mode control logic connection.

**BSB1 (RI.30)** defines the bias value during Standby mode in Loop 1.

**BOF1 (RI.31)** defines the bias value during Off mode in Loop 1.

For Dual PID and Dual On/Off only:

**BSB2 (RI.47)** defines the bias value during Standby mode in Loop 2.

**BSF2 (RI.48)** defines the bias value during Off mode in Loop 2.

The mode status of the controller can be read at Item **PMnST (RI.72)** as follows:

X13 = Standby Mode (SB)

X12 = Off Mode (OF)

## Remote Mode

In Remote mode, the local setpoint is excluded from the calculation of the working setpoint, and the WSP cannot be modified from the front panel of the controller.

### *Via the GX Tool*

Select the defined PMn, then **Data** in the module menu. At the **Remote mode: (0 = N) = field**, enter 0 or 1:

If 0, the module will calculate from:  $WSP = RV * (LSP + RSP) + bias$

If 1, the module will calculate from:  $WSP = RV * (RSP) + bias$

### *Via the SX Tool*

Under **Program Modules**, select the PID Module and set bit X8 in Item **PMnOPT** (RI.01):

X8 = 0 No Remote mode.

X8 = 1 Remote mode enabled.

## Minimum/ Maximum Working Setpoint

For the DX-9100, Version 1.1 or later, the calculated WSP value cannot lie outside of limits set either by numeric connections or entered parameters. If there are no connections, the values entered at Minimum Working Setpoint and Maximum Working Setpoint will be used. When modifying the WSP from the front panel of the controller, it is not possible to set a value for WSP, which lies outside of the set limits.

### *Via the GX Tool*

Select the defined PMn. Then select **Data** in the module menu. In the Data Window, select **Data-2** to go to page 2. At the **Minimum WSP (MNWS)** and **Maximum WSP (MXWS)** fields, enter values to not exceed the working setpoint. To use source points for MNWS and MXWS, connect the respective source points to **MNWS@** and **MXWS@**. The values of source points will take priority over entered values.

### *Via the SX Tool*

Under **Program Modules**, select the PID modules and set the following:

**MNWS@** (RI.22) defines numeric connection for Min. WSP.

**MNWS** (RI.35) defines the numeric value of Min. WSP.

**MXWS@** (RI.23) defines the numeric connection for Max. WSP.

**MXWS** (RI.42) defines the numeric value for Max. WSP.

## Output Forcing Actions

Commands from a BAS or connections to logic variables may override the output calculated by the control algorithm, forcing it to a preprogrammed level of 0 or 1 for On/Off algorithms and 0-100% for PID algorithms. While forcing is active, the module will stop calculating until forcing is disabled. Each forcing condition is associated with an output forcing level. The possible forcing conditions, ordered in priority, are:

- Shutoff mode (BAS only)
- Startup mode (BAS only)
- External Forcing mode

The function of each mode may be individually enabled in each control module.

The configuration of startup and shutoff are also described under *Supervisory Mode Control Settings (General Module)*.

## External Forcing

With External Forcing mode, the control module output will assume a configured forcing level between 0 and 100% for PID algorithms and of 0 or 1 for On/Off algorithms, overriding the output limits of the control module.

### ***Via the GX Tool***

Expand source and destination modules. Make a connection between the source point and EF@ in the destination model. When the connection is a 1, the output will go to the value specified at **ExtForce Out Level** (provided **Shutoff** and **Startup** are not active).

Select the defined PMn. Then select **Data** in the module menu. For a PID module, at the **ExtForce Out Level (EFL)** field, enter the desired level as a number in percent of output. For On/Off modules at the **ExtForce Out Level** field enter 0 for Off and 1 for On.

### ***Via the SX Tool***

External forcing is a software connection, which is configured by entering the source address of the selected logic variable under **Program Modules**, at the Alg. Item location **EF@** (RI.17) of the defined PID module.

The forcing level for PID controllers is read and modified at the Item location **EFL** (RI.59) of the defined PID module.

The forcing level for On/Off controllers is entered at Item location **OPT**, bit X6:

X6 = 1 = On

X6 = 0 = Off

The status of the modes can be seen at Alg. Item **PMnST** (RI.72) follows:

X9 = Shutoff mode (SOFF)

X10 = Startup mode (STUP)

X11 = External Forcing (EF)

### **Programmable Module Notes**

1. The WSP, off mode bias, and standby bias can be read and modified by the DX front panel. See *Display Panel and Keypads* in the *DX-9100 Extended Digital Controller Technical Bulletin (LIT-6364020)* in *FAN 636.4* or *1628.4*.
2. For control module operations refer to Algorithms 1-4 in this document.
3. For details of the Hold mode and Computer mode, refer to *Supervisory Mode Control Settings (General Module)* later in this document.
4. When the PID algorithm is using integral action, forcing actions to either a PID or a connected AO will modify the integral term (I Term) such that the internally calculated output of the control module is equal to the forced value. This provides bumpless transfer when the forcing is removed. In other words when the forcing is removed, the output does not immediately change, but integrates to the new control output value. If there is another module between the PID module and the AO (a high selected, for example) and the AO is overridden, the I Term will not be modified.

## Control Algorithm Theory

The DX executes all modules and *all* of its calculations once every second. The calculations below assume that the output low/high limits are 0 to 100.

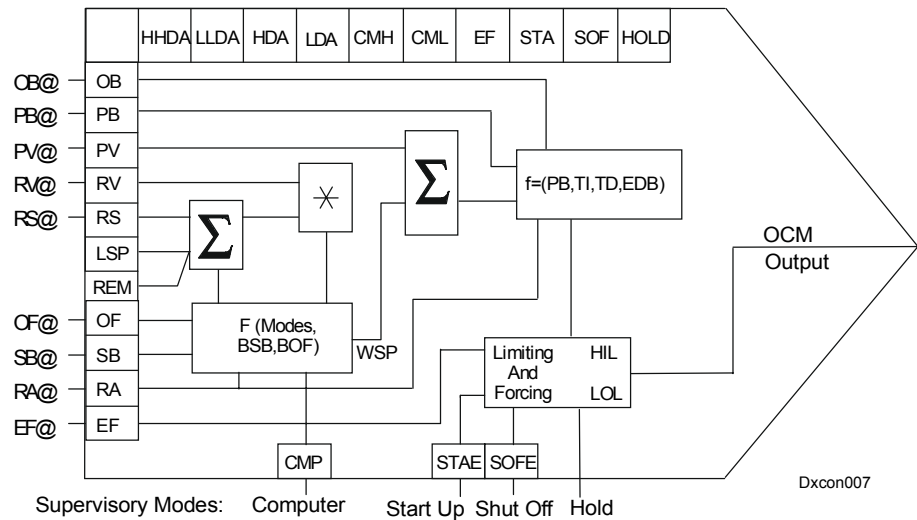

**Figure 7: Control Module Block Diagram**

The PID algorithm is defined by the following equations:

## Proportional Control Algorithm

The standard proportional control algorithm is as follows:

$$P. \text{ Output} = (100/PB) * \text{Deviation} + \text{output bias (OB)}$$

Where:

P. Output = proportional output of control module in %

PB = Proportional Band, defined as the amount of change in the process variable, that produces a change of 0 to 100 on the output of the control module

Deviation = the difference (error) of the Process Variable (PV) and the Working Setpoint (WSP)

With proportional control, the deviation (or control error) is at zero only when the output bias value matches the output value required to attain the setpoint under the actual load conditions.

## Integral Control Algorithm

When using the integral (reset action) in a PID control module, the proportional output is increased or decreased by the integral output which is determined through the following mathematical relationship:

$$I. Output(t) = I. Output(t-1) + (Proportional Output * TI * [1/60])$$

Where:

$$I. Output(t) = \text{Current integral output}$$

$$I. Output(t-1) = \text{Previous integral output}$$

$$TI = \text{Reset action, expressed in repeats of proportional control response per minute}$$

Reset action is used to compensate for the deviation (or error) in proportional control and reduces the deviation towards zero over time.

The integral computation is stopped as soon as the control module output calculates its high or low output limits.

An integral time of zero disables the integral action.

The output of a PI algorithm is:

$$PI \text{ Output} = P. \text{ Output} + I. \text{ Output}$$

Although the PI Output is normally limited to 0-100, the P. Output and I. Output can individually be a negative number.

## Derivative Control Algorithm

When using the derivative action (rate action) in a PID control module, the 0-100 output is modified through the following mathematical calculation:

$$D. Output(t) = [(PV(t) - PV(t-1)) * CD] + (D. Output(t-1) * BD)$$

Where:

$$D. Output(t) = \text{Current Derivative Output}$$

$$D. Output(t-1) = \text{Previous Derivative Output}$$

$$PV(t) = \text{Current Process Variable in \% of input range}$$

$$PV(t-1) = \text{Previous Process Variable in \% of range}$$

$$BD = (60 * TD) / [4 + (60 * TD)]$$

$$CD = 120 * TD * (1 - BD) * 100/PB$$

$$TD = \text{Rate action: a time constant determining the rate of decay of the derivative output to ensure stable control.}$$

Rate action is the braking response in case approach to the setpoint is too rapid and may pass, or the accelerating response in case the deviation from the setpoint is too rapid and may not be corrected quickly enough by PI control.



Most commercial HVAC applications will not require derivative action. A rate action equal to zero disables the derivative term.

The output of a PID algorithm is:

$$\text{PID Output} = \text{P.Output} + \text{I.Output} + \text{D.Output}$$

---

### **Algorithm 01 - PID Control Module**

#### **Setting Supervisory Control Options**

These options are a series of parameters that define how the PID Control Module operates and reacts to BAS commands. For more information, refer to *Supervisory Mode Control Settings (General Module)* later in this document.

#### **Via the GX Tool**

Select the defined PID module. Then select **Data** in the module menu.

At the **Ena Shutoff: 0=N** field, enter a 1 to enable this function.

At the **Shutoff Out Level** field, enter a value for the output to go to if Ena Shutoff = 1 and the BAS has set **Shut off** in the controller.

At the **Ena Startup: 0=N** field, enter a 1 to enable this function. At the **Startup Out Level=** field, enter a value for the output to go to if Ena Startup = 1 and the BAS has set **Startup** in the controller.

At the **Ena Off Trans: 0=N** field, enter a 1 if the module is required to operate in **Off** mode when the BAS has set **Shutoff** and the process variable is below the Off mode working setpoint (WSP). This is only used in reverse acting modules (negative proportional band) for heating applications for low temperature protection.

#### **Via the SX Tool**

These parameters are defined under **Program Modules** at PM Item **PMnOPT (RI.01)** of the PID module, with the following bit structure:

X1 = 1 SOFE Enable Shutoff mode from BAS

X3 = 1 STAE Enable Startup mode from BAS

X9 = 1 SOTO Enable Shutoff to Off Change

**Process Variable  
Connection PV@**

The Process Variable (PV) is an analog value connection to the control module. When the process variable is not equal to the setpoint, the controller responds by changing its output value in accordance with the PID parameters.

***Via the GX Tool***

Make a connection between the source point and PV@ in the destination control module.

***Via the SX Tool***

Under **Program Modules**, configure the software connection by entering the source address of the selected process variable at the **PV@** Item (RI.10) location in the defined PID module.

**Remote Setpoint  
Connection RS@**

The **Remote Setpoint (RSP)** is an analog variable in the control module, in units of PV, which produces a bias in the local setpoint. If the input is not connected, the controller will use the default value 0.

$$WSP = RV (RSP + LSP) + (bias)n$$

***Via the GX Tool***

Make a connection between the source point and RS@ in the destination control module.

***Via the SX Tool***

Configure the software connection by entering the source address of the selected remote setpoint at the **RS@** Item (RI.11) location in the defined PID module.

**Reference  
Variable  
Connection RV@**

The Reference Variable (RV) is an analog variable to the control module, which causes the control module to perform as a ratio controller. Its effect is a multiplier in the working setpoint calculation. If the input is not connected, the controller will use the default value 1.

$$WSP = RV (RSP + LSP) + (bias)n$$

***Via the GX Tool***

Make a connection between the source point and RV@ in the destination control module.

## Proportional Band

### ***Via the SX Tool***

The software connection is configured by entering the source address of the selected reference variable at the **RV@** Item (RI.12) location in the defined PID module.

The proportional band is a number that defines the action and sensitivity of the control module. A negative number defines a reverse acting control module; an increase of the process variable produces a decrease in the output signal. A positive number defines a direct acting control module; an increase of the process variable produces an increase in the output signal.

The number itself is an analog input connection (**PB@**) or value (**PB**) that is expressed as a percentage of the process variable range. When the process variable is one of the eight analog inputs to the DX-9100 Controller, the PV range is the range of the active analog input or the control range of the passive analog input. Otherwise, the range defaults to 0-100 (including all XP analog inputs). The connection is used for an application requiring a dynamic proportional band, and if this input is not connected, the controller will use the proportional band value of PB.

The number itself defines the percentage of the process variable range change that will produce a full output signal change. For example, if the process variable has a control range of 0 to 100, a proportional band of 2% indicates that a change of 2 in the process variable will cause the control module output signal to change by 100%. If the process variable range is 0-40, a proportional band of 10% indicates that a change of 4 in the process variable will cause the control module output signal to change by 100%.

### ***Via the GX Tool***

Select the defined PID. Then select **Data** in the module menu. In the Data Window, select **Data-2** to go to page 2. At the **Proport. Band (PB)** field, enter the required value.

Alternatively, make a connection between the source point and **PB@** of the control module.

### ***Via the SX Tool***

Under **Program Modules**, select the PID module. The software connection is configured by entering the source address of the selected proportional band at the **PB@** Item (RI.13) location in the defined PID module; *or*, enter a value for the proportional band at the **PB** Item (RI.27) location.

## Reverse Action Connection RA@

The Reverse Action Connection is a logic input to the control module, which changes its action from direct to reverse or vice versa.

If the input is not connected, the controller uses the default value 0 and the function is disabled such that the defined action in PB is always used. The reverse action connection should not normally be used when the controller is configured as symmetric.

The DX front panel will *not* show that the PB has been reversed by this connection.

### ***Via the GX Tool***

Make a connection between the source point and the RA@ point of the destination control module.

### ***Via the SX Tool***

Configure the software connection by entering the source address of the selected reverse action logic variable at the RA@ Item (RI.16) location in the defined PID modules.

## Output Bias

The Output Bias Connection or OB@ is an analog input to the control module which biases the value of the output. If the input is not connected, the controller uses the output bias value **OB**. This option is normally used in a proportional-only control module where the value of **OB** determines the output of the control module when the PV is equal to the WSP.

### ***Via the GX Tool***

Make a connection between the source point and the OB@ destination point.

Select the defined PID. Then select **Data** in the module menu. In the Data Window, select **Data-2** to go to page 2. At the **Output Bias (OB)** field, enter a value from 0 to 100. In a P-only controller, this will be the output value when PV = WSP.

### ***Via the SX Tool***

Configure the software connection by entering the source address of the selected output bias at the OB@ Item (RI.20) location. Alternatively, enter the output bias value at the OB Item (RI.34) location.

## Local Setpoint

The local setpoint or LSP is a value that represents the basic setpoint of the control module. It is a number that should be within the range of the process variable. The LSP is disabled (ignored) in Remote mode. When a WSP adjustment is made from the front panel, it is the LSP that is actually changed according to the formula below:

$$\text{WSP} = \text{RV} (\text{RSP} + \text{LSP}) + \text{bias}$$

### *Via the GX Tool*

Select the defined PID. Then select **Data** in the module menu. In the Data Window, select **Data-2** to go to page 2. At the **Local Setpoint (LSP)** field, enter the setpoint of the module.

To enable the Remote mode, enter a 1 at the **Remote mode: 0 = N** field. If 1, the setpoint will be calculated as follows:

$$\text{WSP} = \text{RV} (\text{RSP}) + \text{bias}$$

### *Via the SX Tool*

Under **Program Modules**, select the PID module and enter a value for the local setpoint at the **LSP Item (RI.26)** location. To enable the Remote mode, set Alg. Item **REM (RI.01)**, bit X8 to 1.

## Reset Action

Reset action or TI is a number that defines the integration time for proportional-integral type control modules and is expressed in repeats per period of 1 minute, between 0 and 60, with one decimal place. The integral time  $T_n$  may be computed from this number using the formula:  $T_n = 1/\text{TI}$ . Reset action should normally be set to 0 for symmetrical action controllers.

Note: To clear the reset action from the DX front panel, set the value to any negative number.

### *Via the GX Tool*

Select the defined PID. Then select **Data** in the module menu. In the Data Window, select **Data-2** to go to page 2. At the **Reset Action (TI)** field, enter a value between 0 and 60.

### *Via the SX Tool*

Under Program Modules, select the PID module and enter a value for the reset action at the **TI Item (RI.28)** location. A zero number and all negative numbers will disable the integral action of the controller.

## Rate Action

Rate action or TD defines the derivative action decay time parameter and is entered in minutes, between 0 and 5, with one decimal place. Rate action should normally be set to 0 for symmetrical action controllers.

Note: To clear the rate action from the DX front panel, set the value to any negative number.

### *Via the GX Tool*

Select the defined PID. Then select **Data** in the module menu. In the Data Window, select **Data-2** to go to page 2. At the **Rate Action (TD)** field, enter a value between 0 and 5.

### *Via the SX Tool*

Under **Program Modules**, select the PID module and enter a value for the rate action at the **TD** Item (RI.29) location. A zero number and all negative numbers will disable the rate action of the controller.

## Output High Limit

The High Limit or HIL is a number in percent of the output, which defines a high limit value for the control module output. The default value is 100, and must always be higher than the low limit.

### *Via the GX Tool*

Select the defined PID. Then select **Data** in the module menu. In the Data Window, select **Data-2** to go to page 2. At the **Out High Lmt (HIL)** field, enter the high limit in terms of percentage.

### *Via the SX Tool*

Enter the high limit value at Item **HIL** (RI.36) in the defined PID module.

## Output Low Limit

The Low Limit or LOL is a number in percent of the output, which defines a low limit value for the control module output. The default value is 0, and must always be lower than the high limit. The lower limit is overridden when the control module is in Off mode and the output falls to 0.

### *Via the GX Tool*

Select the defined PID. Then select **Data** in the module menu. In the Data Window, select **Data-2** to go to page 2. At the **Out Low Lmt (LOL)** field, enter the lower limit in terms of percentage.

### Via the SX Tool

Enter the low limit value at Item **LOL** (RI.37) in the defined PID module.

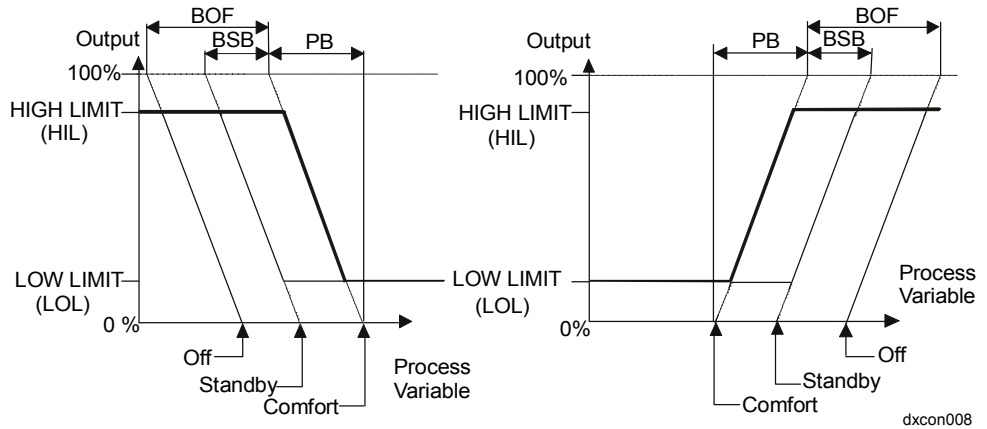

**Figure 8: Reverse Acting Controller (Negative PB)/  
Direct Acting Controller (Positive PB)**

### Deviation Alarm Values

The *deviation alarm values* define the values which, when exceeded by the difference between the process variable and the working setpoint, will automatically generate a deviation alarm.

A *low low deviation alarm* indicates that the process variable is lower than the working setpoint by more than the low low deviation alarm value.

### Via the GX Tool

Select the defined PID. Then select **Data** in the module menu. In the Data Window, select **Data-2** to go to page 2. At the **Dev L. L. Limit (DLL)** field, enter a value in units of PV.

### Via the SX Tool

The low low deviation alarm value can be entered at Alg. Item **DLL** (RI.41).

A *low deviation alarm* indicates that the process variable is lower than the working setpoint by more than the low deviation alarm value.

### ***Via the GX Tool***

Select the defined PID. Then select **Data** in the module menu. In the Data Window, select **Data-2** to go to page 2. At the **Dev Low Limit (DL)** field, enter a value in units of PV.

### ***Via the SX Tool***

The *low deviation alarm* value can be entered at Alg. Item **DL** (RI.40). A high deviation alarm indicates that the process variable exceeds the working setpoint by more than the high deviation alarm value.

### ***Via the GX Tool***

Select the defined PID. Then select **Data** in the module menu. In the Data Window, select **Data-2** to go to page 2. At the **Dev High Limit (DH)** field, enter a value in units of PV.

### ***Via the SX Tool***

The high deviation alarm value can be entered at Alg. Item **DH** (RI.39). A *high high deviation alarm* indicates that the process variable exceeds the working setpoint by more than the high high deviation alarm value.

### ***Via the GX Tool***

Select the PID. Then select **Data** in the module menu. In the Data Window, select **Data-2** to go to page 2. At the **Dev H. H. Limit (DHH)** field, enter a value in units of PV.

### ***Via the SX Tool***

The high high deviation alarm value can be entered at Alg. Item **DHH** (RI.38).

Note: Except for the PID to P changeover described next, deviation alarms do not affect the control program operation unless the associated logic variables are used in other programmable modules. Deviation alarms do not light the LED on the DX front panel.

## **Enable PID to P**

If a PID control module is in a high high or low low deviation alarm condition, it will operate as a proportional-only control module when Enable PID to P is set. The Enable PID to P change on deviation alarm feature sets the integral term to zero when the process variable is far from setpoint, and the controller will convert from a PI or PID controller to a proportional only controller. This is done to prevent wind-up of the integration term when the process variable is outside of the normal control range.



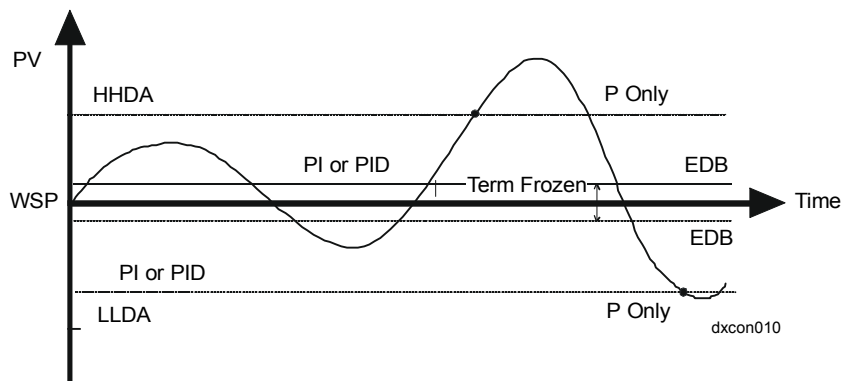

**Figure 9: Enable PID to P**

***Via the GX Tool***

Select the defined PID. Then select **Data** in the module menu. At the **Ena PID to P: 0=N** field, entering a 1 will enable this feature.

***Via the SX Tool***

This parameter is defined through **Program Modules** at PM Item **PMnOPT (RI.01)** in the PID module, with the following bit structure:

X7 = 1 PIDP Enable PID to P change automatically on the Deviation Alarm (LLDA or HHDA).

**Error Deadband**

The *error deadband* is defined in % of the proportional band PB. When the process error (PV-WSP) is within this deadband, the integral term is frozen. The deadband is applied above and below setpoint and in the units of the PV is equal to:

$$(EDB/100) * (PB/100) * \text{Range of the PV (AIn)}$$

or

$$(EDB/100) * (PB/100) * 100 \text{ (all other numeric values)}$$

***Via the GX Tool***

Select the defined PID. Then select **Data** in the module menu. In the Data Window, select **Data-2** to go to page 2. At the **Err Dadband (EDB)** field, enter the value for the desired error deadband.

***Via the SX Tool***

The error deadband is entered in Item **EDB (RI.33)** in the PID Module.

## Symmetrical Transfer Function

The control algorithm may be configured to operate as a P controller with a *symmetrical transfer function*, where the comfort cooling setpoint is calculated by adding a constant symmetry band to the comfort heating setpoint and the control module action is reversed. When the control module is in Standby or Off mode, there is a shift of the setpoints as shown in the figure below. For correct symmetrical operation, the controller must normally be set up as a reverse acting (heating) proportional controller, with no integral or derivative action, and the reverse action connection RA@ is not used.

Use this option when you need a single setpoint for two control loops. Use a dual module for two setpoints.

### Via the GX Tool

Select the defined PID. Then select **Data** in the module menu. At the **Ena Symm** mode: 0=N field, enter 1 to enable this feature.

Then select **Data-2** to go to page 2, and at the **Symmetry Band (SBC)** field, enter a value to add to the setpoint to determine the cooling setpoint.

### Via the SX Tool

This symmetric operation is enabled under **Program Modules** at PM Item **PMnOPT**, bit X5 (RI.01) in the PID module. The symmetry band constant is entered at Item **SBC** (RI.32).

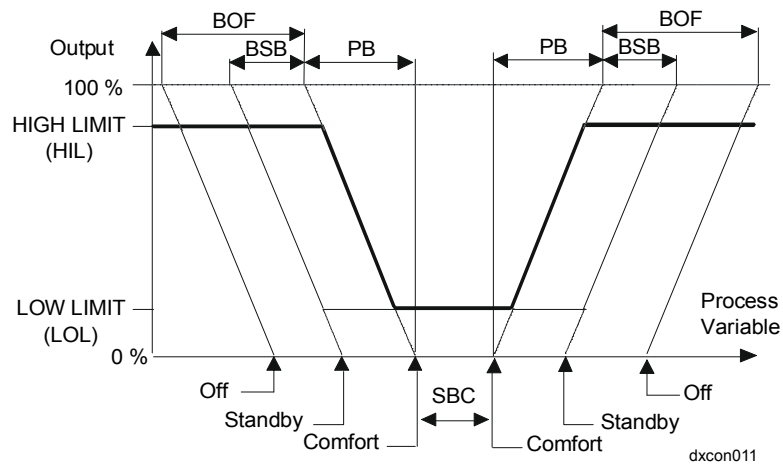

**Figure 10: Controller with Symmetric Operation (Proportional Controller Only)**

## Notes

1. The output, biases, PB, rate, and reset parameters can be read and modified from the DX front panel. See *Display Panel and Keypads* in the *DX-9100 Extended Digital Controller Technical Bulletin (LIT-6364020)* in *FAN 636.4* or *1628.4*.
2. With the SX Tool, the various outputs of the control algorithm can be seen at Items **OCM** (RI.60), **WSP** (RI.61), **PV** (RI.62), **RSP** (RI.66), and **RV** (RI.67).
3. The logic status of the control algorithm can be seen at PM Item **PMnST** (RI.72) with the SX Tool, with the following bit structure:

|         |      |   |
|---------|------|---|
| X1 = 1  | CML  | Controller Output at Low Limit  |
| X2 = 1  | CMH  | Controller Output at High Limit   |
| X3 = 1  | FORC | Force-back to OCM from AO is active.<br><br>FORC is set when the connected AO (analog output) is in Hold mode. The value of the AO is also forced back, or set into the OCM, to provide bumpless override control for a PID module with an integral action. |
| X5 = 1  | LLDA | Low Low Deviation Alarm   |
| X6 = 1  | LDA  | Low Deviation Alarm   |
| X7 = 1  | HDA  | High Deviation Alarm  |
| X8 = 1  | HHDA | High High Deviation Alarm   |
| X9 = 1  | SOF  | Shutoff mode Active   |
| X10 = 1 | STA  | Startup mode Active   |
| X11 = 1 | EF   | External Forcing Active   |
| X12 = 1 | OF   | Off Mode Active   |
| X13 = 1 | SB   | Standby Mode Active   |
| X14 = 1 | RA   | Reverse Action Mode   |
| X15 = 0 | HEAT | (Cooling Controller or PV above center of SBC in Symmetric Operation)   |
| X15 = 1 | HEAT | (Heating Controller or PV below center of SBC in Symmetric Operation)   |

Status Items can be used as logic (digital) connections using the GX Tool or SX Tool.

## GX Labels

### Source Points (Outputs)

|                |   |
|----------------|---|
| <b>PMnCMH</b>  | A 1 when a control module's output is equal to its output <i>high</i> limit.  |
| <b>PMnCML</b>  | A 1 when a control module's output is equal to its output <i>low</i> limit.   |
| <b>PMnCMP</b>  | A 1 when the control module's WSP is being overridden by a BAS (Computer mode).   |
| <b>PMnEF</b>   | A 1 when this control module is being <i>externally forced</i> .  |
| <b>PMnHDA</b>  | A 1 when the difference PV - WSP is larger than the <i>high deviation alarm</i> value.  |
| <b>PMnHEAT</b> | A 1 when, in a symmetric control module, the PV is below the center of the symmetry band, and a 0 when above center; or a 1 when, in a dual control module, Loop 1 is active. |
| <b>PMnHHDA</b> | A 1 when the difference PV - WSP is larger than the <i>high high deviation alarm</i> value.   |
| <b>PMnHLD</b>  | A 1 when the program module is in the Hold mode, being overridden by the SX Tool or a BAS.  |
| <b>PMnLDA</b>  | A 1 when the difference WSP - PV is larger than the <i>low deviation alarm</i> value.   |
| <b>PMnLLDA</b> | A 1 when the difference WSP - PV is larger than the <i>low low deviation alarm</i> value.   |
| <b>PMnLSP</b>  | The value of the local setpoint. (This value is changed when adjusting the WSP from the DX front panel.)  |
| <b>PMnOCM</b>  | The value of the PID control module output in percent; either a 1 or 0 for an On/Off control module.  |
| <b>PMnSOF</b>  | A 1 when this control module is in the Shutoff mode, which occurs when enable shutoff = 1 and the BAS has commanded it On.  |
| <b>PMnSTA</b>  | A 1 when this control module is in the Startup mode, which occurs when enable startup = 1 and the BAS has commanded it On.  |
| <b>PMnWSP</b>  | The value of a control module <i>working setpoint</i> .   |

### ***Destination Points (Inputs)***

|              |   |
|--------------|---|
| <b>EF@</b>   | The connection to the <i>external forcing</i> point of control modules.   |
| <b>MNWS@</b> | The connection to the <i>minimum working setpoint</i> of a control module. The WSP cannot be adjusted below this value. |
| <b>MXWS@</b> | The connection to the <i>maximum working setpoint</i> of a control module. The WSP cannot be adjusted above this value. |
| <b>OB@</b>   | The connection of an <i>output bias</i> value of a PID module.  |
| <b>OF@</b>   | The connection to the <i>off-mode</i> source point of a control module.   |
| <b>PB@</b>   | The connection to <i>proportional band</i> , which replaces the value PB if there is a connection.                      |
| <b>PV@</b>   | The connection to the <i>process variable</i> of a PID or an On/Off.  |
| <b>RA@</b>   | The connection to the <i>reverse action</i> point of a control module.  |
| <b>RS@</b>   | The connection to a <i>remote setpoint</i> , which is used in the calculation for the working setpoint.                 |
| <b>RV@</b>   | The connection to <i>reference variable</i> which is a multiplier in the calculation for the working setpoint.          |
| <b>SB@</b>   | The connection to the <i>standby</i> source point of a control module.  |

---

## Algorithm 02 - On/Off Control Module

### Setting Supervisory Control Options

These options are a series of parameters that define how the On/Off Control Module operates and reacts to BAS commands.

#### ***Via the GX Tool***

Select the defined On/Off module. Then select **Data** in the module menu. At the **Ena Shutoff: 0=N** field, enter a 1 to enable this function.

At the **Shutoff Out Level** field, enter 0 for Off and 1 for On. It will go to the specified state if Shutoff is enabled *and* the BAS has set **Shutoff** in the controller.

At the **Ena Startup: 0=N** field, enter a 1 to enable the function.

At the **Startup Out Level** field, enter 0 for Off and 1 for On. It will go to the specified state if Startup is enabled, *and* the BAS has set **Startup** in the controller.

#### ***Via the SX Tool***

These parameters are defined under **Program Modules** at PM Item **PMnOPT** (RI.01) of the On/Off module, with the following bit structure:

|        |      |                              |
|--------|------|------------------------------|
| X1 = 1 | SOFE | Enable Shutoff mode from BAS |
| X2     | SOFL | 0=0, 1=1 Shutoff out level   |
| X3 = 1 | STAE | Enable Startup mode from BAS |
| X4     | STAL | 0=0, 1=1 Startup out level   |

### Process Variable Connection PV

The Process Variable (PV) is an analog value connection to the control module. When the process variable is not equal to the setpoint, the controller responds by changing its output value in accordance with the On/Off parameters.

#### ***Via the GX Tool***

Make a connection between the source point and PV@ in the destination control module.

#### ***Via the SX Tool***

Configure the software connection by entering the source address of the selected process variable at Alg. Item **PV@** (RI.10) in the defined On/Off module.

**Remote Setpoint  
Connection RS@**

The Remote Setpoint (RSP) is an analog variable in the control module, in units of PV, which produces a bias in the local setpoint. If the input is not connected, the controller will use the default value 0.

$$WSP = RV (RSP + LSP) + bias$$

***Via the GX Tool***

Make a connection between the source point and RS@ in the destination control module.

***Via the SX Tool***

Configure the software connection by entering the source address of the selected remote setpoint at Alg. Item **RS@** (RI.11) in the defined On/Off module.

**Reference  
Variable  
Connection RV@**

The Reference Variable (RV) is an analog variable to the control module, which causes the control module to perform as a ratio controller. Its effect is a multiplier in the working setpoint calculation. If the input is not connected, the controller will use the default value 1.

$$WSP = RV (RSP + LSP) + bias$$

***Via the GX Tool***

Make a connection between the source point and RV@ in the destination control module.

***Via the SX Tool***

Configure the software connection by entering the source address of the selected reference variable at Alg. Item **RV@** (RI.12) in the defined On/Off module.

**Reverse Action  
Connection RA@**

The Reverse Action connection or **RA@** is a logic input to the control module which changes its action from direct to reverse or vice versa. If the input is not connected, the controller will use the default value 0 and the function is disabled such that the defined action in ACT is always used.

Note: When reverse action is a logic 1, the DX front panel PB will *not* show that it has been reversed.

### ***Via the GX Tool***

Make a connection between the source point and RA@ in the destination control module.

### ***Via the SX Tool***

Configure the software connection by entering the source address of the selected reverse action logic variable at Alg. Item RA@ (RI.16).

## **Local Setpoint**

The Local Setpoint or LSP is a value that represents the basic setpoint of the control module. It is a number that should be within the range of the process variable. The LSP is disabled when Remote mode is enabled. When a WSP adjustment is made from the front panel, it is the LSP that is actually changed according to the formula below:

$$\text{WSP} = \text{RV} (\text{RSP} + \text{LSP}) + \text{bias}$$

### ***Via the GX Tool***

Select On/Off. Then select **Data** in the module menu. In the Data Window, select **Data-2** to go to page 2. At the **Local Set Pt (LSP)** field, enter the setpoint of the module.

### ***Via the SX Tool***

Under **Program Modules**, select the On/Off module and enter a value for the local setpoint at Alg. Item **LSP** (RI.26).

## **Action Mode**

The Action mode or ACT is a value that defines the action of the control module. A -1 will define a reverse acting control module; a *decrease* of the process variable below WSP will cause the output to switch to On (1). A +1 will define a direct acting control module; an *increase* of the process variable above WSP will cause the output to switch to On (1).

### ***Via the GX Tool***

Select On/Off. Then select **Data** in the module menu. In the Data Window, select **Data-2** to go to page 2. At the **Action (ACT)** field, enter 1 or -1.

### ***Via the SX Tool***

Under **Program Modules**, select the On/Off module and enter 1 or -1 as the Action mode at Alg. Item **ACT** (RI.27).



## Differential

The differential or DIF is a number that defines the change in process variable required to initiate Off transitions once the output is On. It is used to eliminate short-cycling.

### **Via the GX Tool**

Select On/Off. Then select **Data** in the module menu. In the Data Window, select **Data-2** to go to page 2. At the **Differential (DIF)** field, enter the amount of change to cause an Off transition in the units of the PV.

### **Via the SX Tool**

Configure the software by entering a value for the selected differential logic variable at Alg. Item **DIF** (RI.28) in the On/Off module.

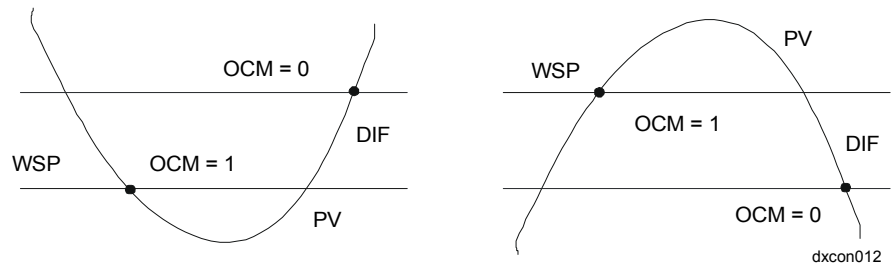

**Figure 11: Reverse Acting Controller/Direct Acting Controller**

## Deviation Alarm Values

The *deviation alarm values* define the value which, when exceeded by the difference between the process variable and the working setpoint, will automatically generate a deviation alarm.

A *low low deviation* alarm indicates that the process variable is lower than the working setpoint by more than the low low deviation alarm value.

### **Via the GX Tool**

Select On/Off. Then select **Data** in the module menu. In the Data Window, select **Data-2** to go to page 2. At the **Dev L. L. Limit (DLL)** field, enter a value in units of PV.

### **Via the SX Tool**

Enter the low low deviation alarm value at Alg. Item **DLL** (RI.41).

A *low low deviation* alarm indicates that the process variable is lower than the working setpoint by more than the low deviation alarm value.

### ***Via the GX Tool***

Select On/Off. Then select **Data** in the module menu. In the Data Window, select **Data-2** to go to page 2. At the **Dev Low Limit (DL)** field, enter a value in units of PV.

### ***Via the SX Tool***

Enter the low deviation alarm value at Alg. Item **DL** (RI.40).

A *high deviation* alarm indicates that the process variable exceeds the working setpoint by more than the high deviation alarm value.

### ***Via the GX Tool***

Select On/Off. Then select **Data** in the module menu. In the Data Window, select **Data-2** to go to page 2. At the **Dev High Limit (DH)** field, enter a value in units of PV.

### ***Via the SX Tool***

Enter the high deviation alarm value at Alg. Item **DH** (RI.39).

A *high high deviation* alarm indicates that the process variable exceeds the working setpoint by more than the high deviation alarm value.

### ***Via the GX Tool***

Select On/Off. Then select **Data** in the module menu. In the Data Window, select **Data-2** to go to page 2. At the **Dev H. H. Limit (DHH)** field, enter a value in units of PV.

### ***Via the SX Tool***

Enter the high high deviation alarm value at Alg. Item **DHH** (RI.38).

Note: Deviation alarms do not affect the control program operation unless the associated logic variables are used in other programmable modules. Deviation alarms do not light the LED on the DX front panel.

## **Symmetrical Transfer Function**

The control algorithm may be configured to operate as an On/Off controller with a *symmetrical transfer function*, where the comfort cooling setpoint is calculated by adding a constant *symmetry band* to the comfort heating setpoint and the control module action is reversed.

When the control module is in Standby or Off mode, there is a shift of the setpoints, as shown in the Figure 12. When the controller is configured as direct action (ACT = +1) the output is at 1 within the symmetry band (SBC).

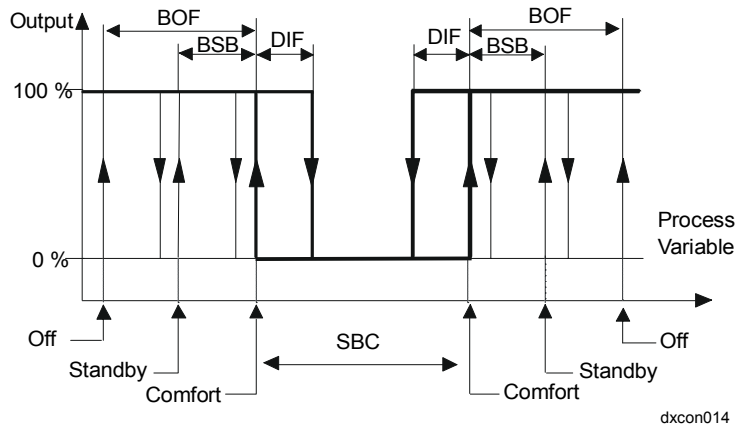

**Figure 12: On/Off Controller with Symmetric Operation (ACT = -1)**

**Via the GX Tool**

Select On/Off. Then select **Data** in the module menu. At the **Ena Symm** mode 0=N field, enter 1 to enable or 0 to disable this function.

If enabled, select **Data-2** to go to page 2. At the **Symmetry Band (SBC)** field, enter a value to add to the setpoint to determine the cooling setpoint.

**Via the SX Tool**

This symmetric operation is enabled at bit X5, PM Type **PMnOPT** (RI.01) in the On/Off module. The symmetry band is entered at Alg. Item **SBC** (RI.32).

**Notes**

1. The WSP, output, biases, and action mode values can be read and modified from the DX front panel. See *Display Panel and Keypads* in the *DX-9100 Extended Digital Controller Technical Bulletin (LIT-6364020)* in *FAN 636.4* or *1628.4*.
2. With the SX Tool, the active values of the control algorithm can be seen at Alg. Items **WSP** (RI.61), **PV** (RI.62), **RSP** (RI.66), and **RV** (RI.67).
3. The output of the control algorithm can be seen at PM Item **PMnDO** (RI.71) bit X1 (Alg. Item **OCM**).

4. The logic status of the control algorithm can be seen at PM Item **PMnST** (RI.72), with the following bit structure:

|         |      |   |
|---------|------|---|
| X1 = 1  | CML  | Controller Output at 0  |
| X2 = 1  | CMH  | Controller Output at 1  |
| X5 = 1  | LLDA | Low Low Deviation Alarm   |
| X6 = 1  | LDA  | Low Deviation Alarm   |
| X7 = 1  | HDA  | High Deviation Alarm  |
| X8 = 1  | HHDA | High High Deviation Alarm   |
| X9 = 1  | SOF  | Shutoff Mode Active   |
| X10 = 1 | STA  | Startup Mode Active   |
| X11 = 1 | EF   | External Forcing Active   |
| X12 = 1 | OF   | Off Mode Active   |
| X13 = 1 | SB   | Standby Mode Active   |
| X14 = 1 | RA   | Reverse Action Mode   |
| X15 = 0 | HEAT | (Cooling Controller or PV above center of SBC in Symmetric Operation) |
| X15 = 1 | HEAT | (Heating Controller or PV below center of SBC in Symmetric Operation) |

Status Items can be used as logic (digital) connections using the GX Tool or SX Tool.

## GX Labels

### Source Points (Outputs)

|                |   |
|----------------|---|
| <b>PMnCMH</b>  | A 1 when a control module's output is equal to its output <i>high</i> limit.  |
| <b>PMnCML</b>  | A 1 when a control module's output is equal to its output <i>low</i> limit.   |
| <b>PMnCMP</b>  | A 1 when the control module's WSP is being overridden by a BAS (Computer mode).   |
| <b>PMnEF</b>   | A 1 when this control module is being <i>externally forced</i> .  |
| <b>PMnHDA</b>  | A 1 when the difference PV - WSP is larger than the <i>high deviation alarm</i> value.  |
| <b>PMnHEAT</b> | A 1 when, in a symmetric control module, the PV is below the center of the symmetry band, and a 0 when above center; or a 1 when, in a dual control module, Loop 1 is active. |
| <b>PMnHHDA</b> | A 1 when the difference PV - WSP is larger than the <i>high high deviation alarm</i> value.   |

|                |  |
|----------------|--|
| <b>PMnHLD</b>  | A 1 when the program module is in the Hold mode, being overridden by the SX Tool or a BAS.                                 |
| <b>PMnLDA</b>  | A 1 when the difference WSP - PV is larger than the <i>low deviation alarm</i> value.                                      |
| <b>PMnLLDA</b> | A 1 when the difference WSP - PV is larger than the <i>low low deviation alarm</i> value.                                  |
| <b>PMnLSP</b>  | The value of the local setpoint. (This value is changed when adjusting the WSP from the DX front panel.)                   |
| <b>PMnOCM</b>  | The value of the PID control module output in percent, either a 1 or 0 for an On/Off control module.                       |
| <b>PMnSOF</b>  | A 1 when this control module is in the Shutoff mode, which occurs when enable shutoff = 1 and the BAS has commanded it On. |
| <b>PMnSTA</b>  | A 1 when this control module is in the Startup mode, which occurs when enable startup = 1 and the BAS has commanded it On. |
| <b>PMnWSP</b>  | The value of a control module working setpoint.  |

#### ***Destination Points (Inputs)***

|              |   |
|--------------|---|
| <b>EF@</b>   | The connection to the <i>external forcing</i> point of control modules.   |
| <b>MNWS@</b> | The connection to the <i>minimum working setpoint</i> of a control module. The WSP cannot be adjusted below this value. |
| <b>MXWS@</b> | The connection to the <i>maximum working setpoint</i> of a control module. The WSP cannot be adjusted above this value. |
| <b>OF@</b>   | The connection to the <i>off-mode</i> source point of a control module.   |
| <b>PV@</b>   | The connection to the <i>process variable</i> of a PID or an On/Off.  |
| <b>RA@</b>   | The connection to the <i>reverse action</i> point of a control module.  |
| <b>RS@</b>   | The connection to a <i>remote setpoint</i> , which is used in the calculation for the working setpoint.                 |
| <b>RV@</b>   | The connection to <i>reference variable</i> , which is a multiplier in the calculation for the working setpoint.        |
| <b>SB@</b>   | The connection to the <i>standby</i> source point of a control module.  |

---

**Algorithm 03 -  
Heating/Cooling  
PID Control  
Module  
(Dual PID)**

The heating/cooling PID Control Module algorithm has two PID control loops, which share the same process variable and control output, and have one set of status variables, but have two different sets of tuning parameters. In Version 1.1 or later, two independent control outputs are also provided, one for each loop. Only one of the two loops will be active, depending on the control status:

PV < WSP1                                      Loop 1 is active.

PV > WSP2                                      Loop 2 is active.

Abs(PV - WSP1) <= Abs(PV - WSP2)      Loop 1 is active.

Note: WSP2 must always be greater than WSP1. Abs stands for absolute.

**Setting  
Supervisory  
Options**

The options are a series of parameters that define how the PID Control Module operates and reacts to BAS commands.

***Via the GX Tool***

Click on **PM** in the toolbar, select **Control**, then **Dual PID**, and position the module (box) on the screen. Select the module and then **Data** to call up the Data Window. At the **Ena Shutoff: 0=N** field, enter a 1 to enable this function.

At the **Shutoff Out Level** field, enter a value for the output to go to if Shutoff is enabled *and* the BAS has set **Shutoff** in the controller.

At the **Ena Startup: 0=N** field, enter a 1 to enable the function.

At the **Startup Out Level** field, enter a value for the output to go to if Startup is enabled *and* the BAS has set **Startup** in the controller.

At the **Ena Off Trans: 0=N** field, enter a 1 so the module will operate in **Off** mode if the BAS has set Shutoff *and* the process variable is below the Off mode WSP. This is only used in a reverse acting loop (negative proportional band) for heating applications for low temperature protection.

***Via the SX Tool***

These parameters are defined under **Program Module** at PM Item **PMnOPT (RI.01)** in the DUAL PID module, with the following bit structure:

X1 = 1 SOFE              Enable Shutoff Mode from BAS

X3 = 1 STAE              Enable Startup Mode from BAS

X9 = 1 SOTO              Enable Shutoff to Off change

**Process Variable  
PV@**

The Process Variable (PV) is an analog value connection to the control module. When the process variable is not equal to the setpoint, the controller responds by changing its output value in accordance with the PID parameters.

***Via the GX Tool***

Make a connection between the source point and PV@ in the destination control module.

***Via the SX Tool***

Configure the software connection by entering the source address of the selected process variable under **Program Modules** at Alg. Item PV@ (RI.10) in the defined DUAL PID module.

**Remote Setpoint  
RS1@, RS2@**

Each of the two remote setpoints (**RSP1, RSP2**) is an analog variable in the control module, in units of PV, which produces a bias in the respective local setpoint. If the input is not connected, the controller will use the default value 0.

$$WSP_n = RV_n (RSP_n + LSP_n) + (bias)_n \quad n = 1, 2$$

***Via the GX Tool***

Make a connection between the source point and RS1@ in the destination control module. Make a connection between the source point and RS2@ in the destination control module.

***Via the SX Tool***

Configure the software connection by entering the source address of the selected remote setpoints under **Program Modules** at Alg. Items RS1@ (RI.11) and RS2@ (RI.18) in the defined DUAL PID module.

**Reference  
Variables RV1@,  
RV2@**

Each of the two reference variables (**RV1, RV2**) is an analog input to the control module, which causes the respective loop in the control module to perform as a ratio controller. Its effect is a multiplier in the working setpoint calculation. If the input is not connected, the controller will use the default value 1.

$$WSP_n = RV_n (RSP_n + LSP_n) + (bias)_n \quad n = 1, 2$$

***Via the GX Tool***

Make a connection between the source point and RV1@ in the destination control module. Make a connection between the source point and RV2@ in the destination control module.

### ***Via the SX Tool***

Configure the software connection by entering the source address of the selected reference variables under **Program Modules** at Alg. Item **RV1@** (RI.12) and **RV2@** (RI.19) in the defined DUAL PID module.

## **Proportional Band**

The proportional band is a number that defines the action and sensitivity of the control module. A negative number defines a reverse acting control module; an increase of the process variable produces a decrease in the output signal. A positive number defines a direct acting control module; an increase of the process variable produces an increase in the output signal.

The number itself is an analog input connection (**PB@**) or value (**PB1 or PB2**) that is expressed in percent of the process variable range. When the process variable is one of the eight analog inputs to the DX-9100 Controller, the PV range is the range of the analog input. Otherwise, the range defaults to 0-100 (including all XP analog inputs). The connection is used for an application requiring a dynamic proportional band and if this input is not connected, the controller will use the proportional band value of PB1 or PB2.

The number itself defines the percentage of the process variable range change that will produce a full output signal change. For example, if the process variable has a control range of 0 to 100, a proportional band of 2% indicates that a change of 2 in the process variable will cause the control module output signal to change by 100%. If the process variable range is 0-40, a proportional band of 10% indicates that a change of 4 in the process variable will cause the control module output signal to change by 100%.

### ***Via the GX Tool***

Make a connection between the source point and **PB1@** in the destination control module. Make a connection between the source point and **PB2@** in the destination control module.

Alternately, select the defined Dual PID. Then select **Data** in the module menu. In the Data Window, select **Data-2** to go to page 2. At the **Proport. Band (PB1)** and **Proport. Band (PB2)** fields, enter the required values.

### ***Via the SX Tool***

Under **Program Modules**, select the DUAL PID module. The software connection is configured by entering the source addresses of the selected proportional band at Alg. Items **PB1** (RI.27) and **PB2** (RI.44); *or*, enter a value for the proportional bands at the PB Items (RI.27, RI.44) location.



## Reverse Action Connection RA@

The reverse action connection is a logic input to the control module, which changes the action of both controllers from direct to reverse or vice versa. Extreme caution is advised when using this connection when setpoint biases are also being used as the sign of the biases is not reversed. For correct controller operation, WSP2 must always be greater than WSP1.

If the input is not connected, the controller will use the default value 0 and the function is disabled such that the defined action in **PB@**, PB1 or PB2 is always used.

### *Via the GX Tool*

Make a connection between the source point and the RA@ point of the destination control module.

### *Via the SX Tool*

Configure the software connection by entering the source address of the selected reverse action logic variable under **Program Modules** at Alg. Item **RA@** (RI.16) in the defined DUAL PID module.

## Output Bias

Each of the two output bias connections (**OB1@**, **OB2@**) is an analog input to the respective loop of the control module which biases the value of the output. If the input is not connected, the controller will use the output bias value **OB1** or **OB2**. This option is normally used in a proportional only control module where the value of **OBn** determines the output of the respective control module when the PV is equal to the WSP.

### *Via the GX Tool*

Make a connection between the source point and the OB1@ point of the destination control module. Make a connection between the source point and the OB2@ destination point.

Select **Dual PID**. Then select **Data** in the module menu. In the Data Window, select **Data-2** to go to page 2. Enter a value at:

- Output Bias #1 (OB1)
- Output Bias #2 (OB2)

### *Via the SX Tool*

Configure the software connection by entering the source address of the selected output bias at Items **OB1@** (RI.20) and **OB2@** (RI.21).

Alternatively, the internal output bias values are set under **Program Modules** at Alg. Items **OB1** (RI.34) or **OB2** (RI.50).

## Local Setpoint

Each of the two local setpoints is a value that represents the basic setpoint of the respective loop in the control module. It is a number that should be within the range of the process variable. **LSP1** and **LSP2** are disabled when Remote mode is enabled. When a WSP1 or WSP2 is adjusted from the front panel, the respective LSP is changed according to the formula below:

$$\text{WSP}_n = \text{RV}_n (\text{RSP}_n + \text{LSP}_n) + (\text{bias})_n \quad n=1,2$$

### *Via the GX Tool*

Select Dual PID. Then select **Data** in the module menu. In the Data Window, select **Data-2** to go to page 2. At the **Local SP #1 (LSP1)** and **Local SP #2 (LSP2)** fields, enter a value in units of PV.

### *Via the SX Tool*

Under **Program Modules**, select the DUAL PID module and enter values for the local setpoints at Alg. Items **LSP1** (RI.26) and **LSP2** (RI.43).

## Reset Actions

Each of the two reset actions is a number which defines the integration time for proportional-integral type control modules and is expressed in repeats per period of 1 minute, between 0 and 60. The integral time (Tn) may be computed from this number using the formula:  $T_n = 1/TI$ .

Note: The integral term of each control loop is frozen when the loop becomes inactive and therefore determines the initial output of the loop when it again becomes active.

### *Via the GX Tool*

Select Dual PID. Then select **Data** in the module menu. In the Data Window, select **Data-2** to go to page 2. At the **Reset Action #1 (TI1)** and **Reset Action #2 (TI2)** fields, enter a value.

### *Via the SX Tool*

Enter a value for the selected reset actions under **Program Modules** at Alg. Items **TI1** (RI.28) or **TI2** (RI.45).

## Rate Actions

Each of the two rate actions defines the derivative action decay time value and is entered in minutes, between 0 and 5.

### *Via the GX Tool*

Select Dual PID. Then select **Data** in the module menu. In the Data Window, select **Data-2** to go to page 2. At the **Rate Action #1 (TD1)** and **Rate Action #2 (TD2)** fields, enter a value.

### *Via the SX Tool*

Enter a value for the selected rate actions under **Program Modules** at Alg. Items **TD1** (RI.29) or **TD2** (RI.46).

## Output High Limits

Each of the two high limits is a percent of the output, which defines a high limit value for the control module output in the respective loop. The default value is 100 for each limit, and must always be higher than the low limit.

### *Via the GX Tool*

Select Dual PID. Then select **Data** in the module menu. In the Data Window, select **Data-2** to go to page 2. At the **Out H Lmt #1 (HIL1)** and **Out H Lmt #2 (HIL2)** fields, enter a value.

### *Via the SX Tool*

Enter a value for the selected high limit under **Program Modules** at Alg. Items **HIL1** (RI.36) and **HIL2** (RI.53).

## Output Low Limits

Each of the two low limits is a percent of the output, which defines a low limit value for the control module output in the respective loop. The default value is 0 for each limit, and must always be lower than the high limit. The low limits are overridden when the control module is in Off mode and the output falls to 0.

### *Via the GX Tool*

Select Dual PID. Then select **Data** in the module menu. In the Data Window, select **Data-2** to go to page 2. At the **Out L Lmt #1 (LOL1)** and **Out L Lmt #2 (LOL2)** fields, enter a value.

### *Via the SX Tool*

Enter a value for the selected low limit under **Program Modules** at Alg. Items **LOL1** (RI.37) and **LOL2** (RI.54).

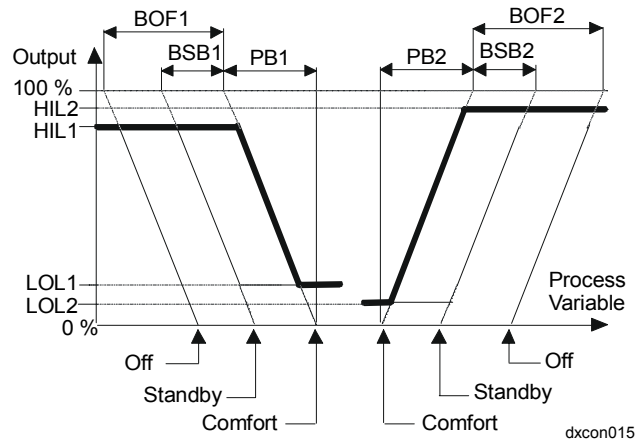

**Figure 13: Heating/Cooling Module Operation**

**Deviation Alarm Values**

The deviation alarm values define the value which, when exceeded by the difference between the process variable and the actual working setpoint, will automatically generate a deviation alarm.

A *low low deviation* alarm indicates that the process variable is lower than the working setpoint of the respective loop by more than the low low deviation alarm value.

**Via the GX Tool**

Select **Dual PID**. Then select **Data** in the module menu. In the Data Window, select **Data-2** to go to page 2. At the **Dev LL Lmt #1 (DLL1)** and **Dev LL Lmt #2 (DLL2)** fields, enter a value in units of PV.

**Via the SX Tool**

The low low deviation alarm value for the respective loop can be entered under **Program Modules** at Alg. Item **DLL1 (RI.41)** and **DLL2 (RI.58)**.

A *low deviation* alarm indicates that the process variable is lower than the working setpoint of the respective loop by more than the low deviation alarm value.

**Via the GX Tool**

Select **Dual PID**. Then select **Data** in the module menu. In the Data Window, select **Data-2** to go to page 2. At the **Dev L Lmt #1 (DL1)** and **Dev L Lmt #2 (DL2)** fields, enter a value in units of PV.

### ***Via the SX Tool***

The low deviation alarm value for the respective loop can be entered under **Program Modules** at Alg. Item **DL1** (RI.40) and **DL2** (RI.57).

A *high deviation* alarm indicates that the process variable exceeds the working setpoint of the respective loop by more than the high deviation alarm value.

### ***Via the GX Tool***

Select **Dual PID**. Then select **Data** in the module menu. In the Data Window, select **Data-2** to go to page 2. At the **Dev H Lmt #1 (DH1)** and **Dev H Lmt #2 (DH2)** fields, enter a value in units of PV.

### ***Via the SX Tool***

The high deviation alarm value for the respective loop can be entered under **Program Modules** at Alg. Item **DH1** (RI.39) and **DH2** (RI.56).

A *high high deviation* alarm indicates that the process variable exceeds the working setpoint of the respective loop by more than the high high deviation alarm value.

### ***Via the GX Tool***

Select **Dual PID**. Then select **Data** in the module menu. In the Data Window, select **Data-2** to go to page 2. At the **Dev HH Lmt #1 (DHH1)** and **Dev HH Lmt #2 (DHH2)** fields, enter a value in units of PV.

### ***Via the SX Tool***

The high high deviation alarm value for the respective loop can be entered under **Program Modules** at Alg. Item **DHH1** (RI.38) and **DHH2** (RI.55).

Note: Except for the PID to P changeover described below, deviation alarms do not affect the control program operation unless the associated logic variables are used in other programmable modules. Deviation alarms do not light the LED on the DX front panel.

### **Enable PID to P**

If a PID control loop has a high high or low low deviation alarm, it will operate as a proportional only loop when the PID to P feature is enabled. (Refer to Figure 9.)

### ***Via the GX Tool***

Select DUAL PID. Then select **Data** in the module menu. At the **Ena PID to P: 0=N** field, enter 1 to enable PID to P transition, or 0 to disable this feature.

### ***Via the SX Tool***

This feature is enabled when Alg. Item PIDP (RI.01) bit X7 is set to 1 under Program Modules.

## **Error Deadband**

The error deadband is expressed in percent of the active proportional band PB1 or PB2. When the process error (PV-WSP) is within this deadband, the integral term is frozen. The deadband is applied above and below setpoint and in the units of the PV is equal to:

$$(EDB/100) * (PB/100) * \text{Range of the PV (AIn)}$$

or

$$(EDB/100) * (PB/100) * 100 \text{ (all other numeric values)}$$

### ***Via the GX Tool***

Select **Dual PID**. Then select **Data** in the module menu. In the Data Window, select **Data-2** to go to page 2. At the **Err Dd Bnd #1 (EDB1)** and **Err Dd Bnd #2 (EDB2)** fields, enter a value in percent of PB.

### ***Via the SX Tool***

The error deadbands are entered under **Program Modules** at Alg. Items **EDB1** (RI.33) and **EDB2** (RI.49).

## **Enable Zero Output Changeover**

When this option is enabled, the changeover from one loop to another will only take place when the output of the active loop is at its low limit. This feature is used when the control loops have integral or derivative action and the process variable can change very quickly. It prevents a loop becoming inactive when its output is above the low limit value due to the integral or derivative term.

When this option is not enabled, the output of the loop will go to its low limit when the loop becomes inactive, and when the loop becomes active again, the output will immediately return to the value at the time of the previous changeover. This may cause unnecessary instability.

When a long integral time is configured, the effect of enabling this option will be to slow down the changeover from heating to cooling or vice-versa when the process variable changes rapidly. The changeover cannot occur until the integral and derivative terms have decayed such that the output is at the low limit value. This feature is available with x.3 controllers or later.

### ***Via the GX Tool***

Select the module and then **Data** to call up the Data Window.

At the Ena zero c/o: 0=N field, enter a 1 to enable this function.

### ***Via the SX Tool***

This parameter is defined under Program Module at PM Item **PMnOPT** (RI.01) in a DUAL PID module as follows:

X10 = 1 EZCO Enable Zero Output Changeover

### **Notes**

1. The WSP1, WSP2, PB1, PB2, OCM, PV, TI1, TI2, TD1, TD2, BOF1, BOF2, BSB1, and BSB2 can be read and modified from the DX front panel. See *Display Panel and Keypads* in the *DX-9100 Extended Digital Controller Technical Bulletin (LIT-6364020)* in *FAN 636.4* or *1628.4*.
2. With the SX Tool, the various outputs of the control algorithm can be seen at Alg. Items **OCM** (RI.60), **WSP1** (RI.61), **WSP2** (RI.62), **PV** (RI.63), **RSP** (RI.66), **RV** (RI.67), **OCM1** (RI.68), and **OCM2** (RI.69).
3. OCM represents the output of the active loop. OCM1 and OCM2, which are only available for Version 1.1 and later, represent the outputs of Loops 1 and 2, respectively.

4. The logic status of the control algorithm can be seen at PM Item **PMnST** (RI.72), with following bit structure:

|        |      |   |
|--------|------|---|
| X1 = 1 | CML  | Controller Output at Low Limit  |
| X2 = 1 | CMH  | Controller Output at High Limit   |
| X3 = 1 | FORC | Force-back to OCM from AO is active.<br><br>FORC is set when the connected AO (analog output) is in Hold mode. The value of the AO is also forced back, or set into the OCM, to provide bumpless override control for a PID module with an integral action.<br><br>Force-back is not active when the AO is connected to OCM1 or OCM2. |
| X5 = 1 | LLDA | Low Low Deviation Alarm   |
| X6 = 1 | LDA  | Low Deviation Alarm   |
| X7 = 1 | HDA  | High Deviation Alarm  |
| X8 = 1 | HHDA | High High Deviation Alarm   |
| X9 = 1 | SOF  | Shutoff Mode Active   |
| X10= 1 | STA  | Startup Mode Active   |
| X11= 1 | EF   | External Forcing Active   |
| X12= 1 | OF   | Off Mode Active   |
| X13= 1 | SB   | Standby Mode Active   |
| X14= 1 | RA   | Reverse Action Mode   |
| X15= 0 | HEAT | Cooling (Loop 2 active) (PV above WSP2)   |
| X15= 1 | HEAT | Heating (Loop 1 active) (PV below WSP1)   |

Status Items can be used as logic (digital) connections using the GX Tool or SX Tool.

## GX Labels

### **Source Points (Outputs)**

|               |   |
|---------------|---|
| <b>PMnCMH</b> | A 1 when a control module's output is equal to its output <i>high</i> limit.    |
| <b>PMnCML</b> | A 1 when a control module's output is equal to its output <i>low</i> limit.     |
| <b>PMnCMP</b> | A 1 when the control module's WSP is being overridden by a BAS (Computer mode). |
| <b>PMnEF</b>  | A 1 when this control module is being <i>externally forced</i> .                |



|                |   |
|----------------|---|
| <b>PMnHEAT</b> | A 1 when, in a symmetric control module, the PV is below the center of the symmetry band, and a 0 when above center; or a 1 when, in a dual control module, Loop 1 is active. |
| <b>PMnHDA</b>  | A 1 when the difference PV - WSP is larger than the <i>high deviation alarm</i> value.  |
| <b>PMnHHDA</b> | A 1 when the difference PV - WSP is larger than the <i>high high deviation alarm</i> value.   |
| <b>PMnHLD</b>  | A 1 when the program module is in the Hold mode, being overridden by the SX Tool or a BAS.  |
| <b>PMnLDA</b>  | A 1 when the difference WSP - PV is larger than the <i>low deviation alarm</i> value.   |
| <b>PMnLLDA</b> | A 1 when the difference WSP - PV is larger than the <i>low low deviation alarm</i> value.   |
| <b>PMnLSP1</b> | The value of the <i>local setpoint</i> of Loop 1 of a dual control module. (This value is directly changed when adjusting the WSP1 from the DX front panel.)                  |
| <b>PMnLSP2</b> | The value of the <i>local setpoint</i> of Loop 2 of a dual control module. (This value is changed when adjusting the WSP2 from the DX front panel.)                           |
| <b>PMnMNWS</b> | The value of the <i>minimum working setpoint</i> allowed for a control module.  |
| <b>PMnMXWS</b> | The value of the <i>maximum working setpoint</i> allowed for a control module.  |
| <b>PMnOCM</b>  | The value of the dual PID <i>control module output</i> in percent.  |
| <b>PMnOCM1</b> | The value of the Loop 1 <i>output</i> in a dual PID <i>control module</i> in percent.   |
| <b>PMnOCM2</b> | The value of the Loop 2 <i>output</i> in a dual PID <i>control module</i> in percent.   |
| <b>PMnSOF</b>  | A 1 when this control module is in the Shutoff mode, which occurs when enable shutoff = 1 and the BAS has commanded it On.  |
| <b>PMnSTA</b>  | A 1 when this control module is in the Startup mode, which occurs when enable startup = 1 and the BAS has commanded it On.  |
| <b>PMnWSP1</b> | The value of the <i>working setpoint</i> of Loop 1 of a dual control module.  |
| <b>PMnWSP2</b> | The value of the <i>working setpoint</i> of Loop 2 of a dual control module.  |

### **Destination Points (Inputs)**

|              |   |
|--------------|---|
| <b>EF@</b>   | The connection to the <i>external forcing</i> point of control modules.   |
| <b>MNWS@</b> | The connection to the <i>minimum working setpoint</i> of a control module. The WSP cannot be adjusted below this value. |
| <b>MXWS@</b> | The connection to the <i>maximum working setpoint</i> of a control module. The WSP cannot be adjusted above this value. |
| <b>OB1@</b>  | The connection for Loop 1 of a dual PID <i>output bias</i> .  |
| <b>OB2@</b>  | The connection for Loop 2 of a dual PID <i>output bias</i> .  |
| <b>OF@</b>   | The connection to the <i>off-mode</i> source point of a control module.   |
| <b>PB@</b>   | The connection to <i>proportional band</i> , which replaces the value PB if there is a connection.                      |
| <b>PV@</b>   | The connection to the <i>process variable</i> of a control module.  |
| <b>RA@</b>   | The connection to the <i>reverse action</i> point of a control module.  |
| <b>RS1@</b>  | The connection for Loop 1 of a dual control module <i>remote setpoint</i> .   |
| <b>RS2@</b>  | The connection for Loop 2 of a dual control module <i>remote setpoint</i> .   |
| <b>RV1@</b>  | The connection for Loop 1 of a dual control module <i>reference variable</i> .  |
| <b>RV2@</b>  | The connection for Loop 2 of a dual control module <i>reference variable</i> .  |
| <b>SB@</b>   | The connection to the <i>standby</i> source point of a control module.  |

---

#### **Algorithm 04 - Heating/ Cooling On/Off Control Module (Dual On/Off)**

The heating/cooling On/Off algorithm has two On/Off Control loops that share the same process variable and control output, and have one set of status variables, but have two different sets of tuning parameters. In Version 1.1 or later, two independent control outputs are also provided, one for each loop. Only one of the two loops will be active, depending on the control status:

|                                      |                   |
|--------------------------------------|-------------------|
| $PV \leq WSP1$                       | Loop 1 is active. |
| $PV \geq WSP2$                       | Loop 2 is active. |
| $Abs(PV - WSP1) \leq Abs(PV - WSP2)$ | Loop 1 is active. |

Note: WSP2 must always be greater than WSP1.

## Setting Supervisory Control Options

The *options* are series of parameters that define how the On/Off Control Module operates and reacts to BAS commands.

### ***Via the GX Tool***

Click on **PM** in the toolbar, select **Control**, then **Dual On/Off** and position the module (box) on the screen. Select the module and then **Data** to call up the Data Window. At the **Ena Shutoff: 0=N** field, enter a 1 to enable this function.

At the **Shutoff Out Level** field, enter 0 for Off and 1 for On. It will go to the specified state if Shutoff is enabled *and* the BAS has set **Shutoff** in the controller.

At the **Ena Startup: 0=N** field, enter a 1 to enable the function.

At the **Startup Out Level** field, enter 0 for Off and 1 for On. It will go to the specified state if Startup is enabled *and* the BAS has set **Startup** in the controller.

### ***Via the SX Tool***

These parameters are defined under Item **PMnOPT** (RI.01) of the D On/Off module, with the following bit structure:

X1 = 1 SOFE Enable Shutoff mode from Supervisory System

X2 SOFL 0=0, 1=1 Shutoff out level

X3 = 1 STAE Enable Startup mode from Supervisory System

X4 STAL 0=0, 1=1 Startup out level

## Process Variable Connection PV@

The Process Variable (PV) is an analog value connection to the control module. When the process variable is not equal to the setpoint, the controller responds by changing its output value in accordance with the On/Off parameters.

### ***Via the GX Tool***

Make a connection between the source point and PV@ in the destination control module.

### ***Via the SX Tool***

Configure the software connection by entering the source address of the selected process variable under **Program Modules** at Item **PV@** (RI.10) in the defined D On/Off module.

**Remote Setpoint Connections  
RS1@, RS2@**

Each of the two remote setpoints (RSP1, RSP2) is an analog variable to the control module, in units of the PV, which produces a bias in the respective local setpoint. If the input is not connected, the controller will use the default value 0.

$$WSPn = RVn (RSPn + LSPn) + (bias)n \quad n = 1, 2$$

***Via the GX Tool***

Make a connection between the source point and RS1@ in the destination control module. Make a connection between the source point and RS2@ destination point.

***Via the SX Tool***

Configure the software connection by entering the source addresses of the selected remote setpoint under **Program Modules** at Alg. Items **RS1@** (RI.11) and **RS2@** (RI.18).

**Reference Variable Connection  
RV1@, RV2@**

Each of the two reference variables (**RV1**, **RV2**) is an analog input to the control module, which causes the respective loop in the control module to perform as a ratio controller. Its effect is a multiplier in the working setpoint calculation. If the input is not connected, the controller will use the default value 1.

$$WSPn = RVn (RSPn + LSPn) + (bias)n \quad n = 1, 2$$

***Via the GX Tool***

Make a connection between the source point and RV1@ in the destination control module. Make a connection between the source point and RV2@ destination point.

***Via the SX Tool***

Configure the software connection by entering the source addresses of the selected reference variable under **Program Modules** at Alg. Items **RV1@** (RI.12) and **RV2@** (RI.19).

**Reverse Action Connection RA@**



**CAUTION:** The reverse action connection is a logic input to the control module which changes the action of both controllers from direct to reverse or vice versa. Extreme caution is advised with this connection when setpoint biases are also being used as the sign of the biases is not reversed. For correct controller operation, WSP2 must always be greater than WSP1.

If the input is not connected, the controller will use the default value 0 and the function is disabled such that the defined action in **ACT1** or **ACT2** is always used.

***Via the GX Tool***

Make a connection between the source point and RA1@ in the destination control module.

***Via the SX Tool***

Configure the software connection by entering the source address of the selected reverse action logic variable under **Program Modules** at Alg. Item **RA@** (RI.16).

**Local Setpoint**

Each of the two local setpoints is a value that represents the basic setpoint of the respective loop in the control module. It is a number that should be within the range of the process variable. The **LSP1** and **LSP2** are disabled when Remote mode is enabled. When a WSP1 or WSP2 is adjusted from the front panel, the respective LSP is changed according to the formula below:

$$WSP_n = RV_n (RSP_n + LSP_n) + (bias)_n \quad n=1, 2$$

***Via the GX Tool***

Click on **PM** in the toolbar, select **Control**, then **Dual On/Off** and position the module (box) on the screen. Select the module and then **Data** to call up the Data Window. At the **Local SP #1 (LSP1)** and **Local SP #2 (LSP2)** fields, enter setpoint values.

***Via the SX Tool***

Enter a value for the selected local setpoints under **Program Modules** at Alg. Items **LSP1** (RI.26) and **LSP2** (RI.43).

**Action Modes**

Each of the two action modes defines the action of the respective loop in the control module. A -1 will define a reverse acting control module; an increase of the process variable will cause the output to switch to Off (0). A +1 will define a direct acting control module; an increase of the process variable will cause the output to switch to On (1). ACT 1 will normally be -1 and ACT 2 will normally be +1 to define a heating/cooling controller.

### Via the GX Tool

Click on **PM** in the toolbar, select **Control**, then **Dual On/Off** and position the module (box) on the screen. Select the module and then **Data** to call up the Data Window. Go to the second page. At the **Action #1 (ACT1)** and **Action #2 (ACT2)** fields, enter a value.

### Via the SX Tool

Enter -1 or +1 for the selected Action mode under **Program Modules** at Alg. Items **ACT1 (RI.27)** and **ACT2 (RI.44)**.

## Differential

Each of the two differential values is a number that defines the change in deviation value required to initiate Off transitions once outputs are On.

### Via the GX Tool

Click on **PM** in the toolbar, select **Control**, then **Dual On/Off** and position the module (box) on the screen. Select the module and then **Data** to call up the Data Window. At the **Differential #1 (DIF1)** and **Differential #2 (DIF2)** fields, enter the amount of change to cause an Off transition in units of the PV.

### Via the SX Tool

Enter a value for the selected differential under **Program Modules** at Alg. Items **DIF1 (RI.2)** or **DIF2 (RI.45)**.

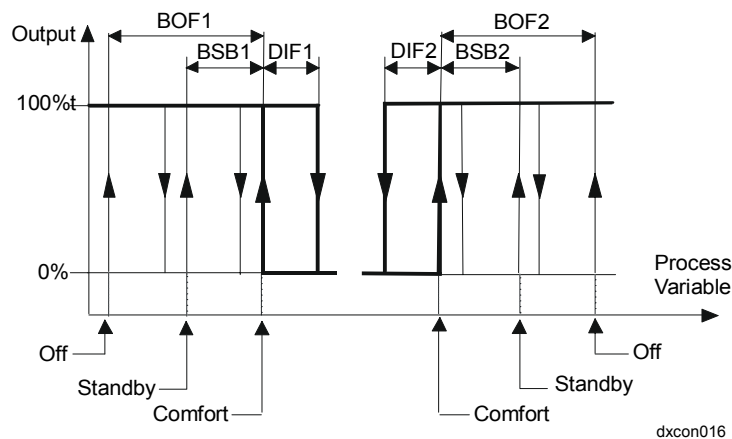

**Figure 14: Heating/Cooling On/Off Module Operation**

## Deviation Alarm Values

The *deviation alarm values* define the value which, when exceeded by the difference between the process variable and the actual working setpoint, will automatically generate a deviation alarm.

A *low low deviation* alarm indicates that the process variable is lower than the working setpoint of the respective loop by more than the low low deviation alarm value.

#### ***Via the GX Tool***

Click on **PM** in the toolbar, select **Control**, then **Dual On/Off**, and position the module (box) on the screen. Select the module and then **Data** to call up the Data Window. At the **Dev LL Lmt #1 (DLL1)** and **Dev LL Lmt #2 (DLL2)** fields, enter a value in units of PV.

#### ***Via the SX Tool***

The low low deviation alarm value for the respective loop can be entered under **Program Modules** at Alg. Item **DLL1** (RI.41) and **DLL2** (RI.58).

A low deviation alarm indicates that the process variable is lower than the working setpoint of the respective loop by more than the low deviation alarm value.

#### ***Via the GX Tool***

Click on **PM** in the toolbar, select **Control**, then **Dual On/Off**, and position the module (box) on the screen. Select the module and then **Data** to call up the Data Window. At the **Dev Low Lmt #1 (DL1)** and **Dev Low Lmt #2 (DL2)** fields, enter a value in units of PV.

#### ***Via the SX Tool***

The low deviation alarm value for the respective loop can be entered under **Program Modules** at Alg. Item **DL1** (RI.40) and **DL2** (RI.57).

A *high deviation* alarm indicates that the process variable exceeds the working setpoint of the respective loop by more than the high deviation alarm value.

#### ***Via the GX Tool***

Click on **PM** in the toolbar, select **Control**, then **Dual On/Off** and position the module (box) on the screen. Select the module and then **Data** to call up the Data Window. At the **Dev H Lmt #1 (DH1)** and **Dev H Lmt #2 (DH2)** fields, enter a value in units of PV.

#### ***Via the SX Tool***

The high deviation alarm value for the respective loop can be entered under **Program Modules** at Alg. Item **DH1** (RI.39) and **DH2** (RI.56).

A *high high deviation* alarm indicates that the process variable exceeds the working setpoint of the respective loop by more than the high high deviation alarm value.

### ***Via the GX Tool***

Click on **PM** in the toolbar, select **Control**, then **Dual On/Off** and position the module (box) on the screen. Select the module and then **Data** to call up the Data Window. At the **Dev HH Lmt #1 (DHH1)** and **Dev HH Lmt #2 (DHH2)** fields, enter a value in units of PV.

### ***Via the SX Tool***

The high high deviation alarm value for the respective loop can be entered under **Program Modules** at Alg. Item **DHH1** (RI.38) and **DHH2** (RI.55).

Note: Deviation alarms do not affect the control program operation unless the associated logic variables are used in other programmable modules. Deviation alarms do not light the LED on the DX front panel.

## **Notes**

1. The WSP1, WSP2, PV, OCM, ACT1, DIF1, BOF1, BSB1, ACT2, DIF2, BOF2, and BSB2 can be read and modified from the DX front panel. See *Display Panel and Keypads* in the *DX-9100 Extended Digital Controller Technical Bulletin (LIT-6364020)* in *FAN 636.4* or *1628.4*.
2. With the SX Tool, the various outputs of the control algorithm can be seen under **Program Modules** at Alg. Items **WSP1** (RI.61), **WSP2** (RI.62), **PV** (RI.63), **RSP** (RI.66), and **RV** (RI.67).
3. The output of the control algorithm can be seen under **Program Modules** at PM Item **PMnDO** (RI.71). OCM represents the output of the active loop. OCM1 and OCM2, which are only available from Version 1.1 and later, represent the outputs of Loops 1 and 2, respectively:  
OCM = bit X1  
OCM1 = bit X2  
OCM2 = bit X3



4. The logic status of the control algorithm can be seen at PM Item **PMnST** (RI.72) with following bit structure:

|        |      |                           |
|--------|------|---------------------------|
| X1 = 1 | CML  | Controller Output at 0    |
| X2 = 1 | CMH  | Controller Output at 1    |
| X5 = 1 | LLDA | Low Low Deviation Alarm   |
| X6 = 1 | LDA  | Low Deviation Alarm       |
| X7 = 1 | HDA  | High Deviation Alarm      |
| X8 = 1 | HHDA | High High Deviation Alarm |
| X9 = 1 | SOF  | Shutoff Mode Active       |
| X10= 1 | STA  | Startup Mode Active       |
| X11= 1 | EF   | External Forcing Active   |
| X12= 1 | OF   | Off Mode Active           |
| X13= 1 | SB   | Standby Mode Active       |
| X14= 1 | RA   | Reverse Action Mode       |
| X15= 0 | HEAT | Cooling (Loop 2 active)   |
| X15= 1 | HEAT | Heating (Loop 1 active)   |

Status Items can be used as logic (digital) connections using the GX Tool or SX Tool.

## GX Labels

### Source Points (Outputs)

|                |   |
|----------------|---|
| <b>PMnCMH</b>  | A 1 when a control module's output is equal to its output <i>high</i> limit.                |
| <b>PMnCML</b>  | A 1 when a control module's output is equal to its output <i>low</i> limit.                 |
| <b>PMnCMP</b>  | A 1 when the control module's WSP is being overridden by a BAS (Computer mode).             |
| <b>PMnEF</b>   | A 1 when this control module is being <i>externally forced</i> .                            |
| <b>PMnHDA</b>  | A 1 when the difference PV - WSP is larger than the <i>high deviation alarm</i> value.      |
| <b>PMnHHDA</b> | A 1 when the difference PV - WSP is larger than the <i>high high deviation alarm</i> value. |
| <b>PMnHLD</b>  | A 1 when the program module is in the Hold mode, being overridden by the SX Tool or a BAS.  |
| <b>PMnLDA</b>  | A 1 when the difference WSP - PV is larger than the <i>low deviation alarm</i> value.       |
| <b>PMnLLDA</b> | A 1 when the difference WSP - PV is larger than the <i>low low deviation alarm</i> value.   |

|                |  |
|----------------|--|
| <b>PMnLSP1</b> | The value of the <i>local setpoint</i> of Loop 1 of a dual control module. (This value is directly changed when adjusting the WSP1 from the DX front panel.) |
| <b>PMnLSP2</b> | The value of the <i>local setpoint</i> of Loop 2 of a dual control module. (This value is changed when adjusting the WSP2 from the DX front panel.)          |
| <b>PMnOCM</b>  | The value of the dual On/Off <i>control module output</i> ; either a 1 or 0  |
| <b>PMnOCM1</b> | The value of the Loop 1 <i>output</i> in a dual On/Off <i>control module</i> ; either a 1 or 0   |
| <b>PMnOCM2</b> | The value of the Loop 2 <i>output</i> in a dual On/Off <i>control module</i> ; either a 1 or 0   |
| <b>PMnSOF</b>  | A 1 when this control module is in the Shutoff mode, which occurs when enable shutoff = 1 and the BAS has commanded it On.                                   |
| <b>PMnSTA</b>  | A 1 when this control module is in the Startup mode, which occurs when enable startup = 1 and the BAS has commanded it On.                                   |
| <b>PMnWSP1</b> | The value of the <i>working setpoint</i> of Loop 1 of a dual control module.   |
| <b>PMnWSP2</b> | The value of the <i>working setpoint</i> of Loop 2 of a dual control module.   |

#### ***Destination Points (Inputs)***

|              |   |
|--------------|---|
| <b>EF@</b>   | The connection to the <i>external forcing</i> point of control modules.   |
| <b>MNWS@</b> | The connection to the <i>minimum working setpoint</i> of a control module. The WSP cannot be adjusted below this value. |
| <b>MXWS@</b> | The connection to the <i>maximum working setpoint</i> of a control module. The WSP cannot be adjusted above this value. |
| <b>OF@</b>   | The connection to the <i>off-mode</i> source point of a control module.   |
| <b>PV@</b>   | The connection to the <i>process variable</i> of a control module.  |
| <b>RA@</b>   | The connection to the <i>reverse action</i> point of a control module.  |
| <b>RS1@</b>  | The connection for Loop 1 of a dual control module <i>remote setpoint</i> .   |

- RS2@** The connection for Loop 2 of a dual control module *remote setpoint*.
- RV1@** The connection for Loop 1 of a dual control module *reference variable*.
- RV2@** The connection for Loop 2 of a dual control module *reference variable*.
- SB@** The connection to the *standby* source point of a control module.

---

**Numerical  
Calculation and  
Other Function  
Module  
Configurations**

Each of the twelve programmable function modules can be defined as a numerical calculation module or other type of control module, capable of executing a mathematical or control algorithm.

Each module can accept numeric and logic variable inputs and each module provides a numeric and/or logic output that can be connected to either a programmable function module or output module.

---

**Algorithm 11 -  
Average**

The average algorithm calculates the arithmetic average of up to eight connected inputs. If one of the inputs is not connected, the calculation module will assume a value of 1 for the corresponding variable.

Each input may be weighted with a constant K.

$$\frac{(I1*K1 + I2*K2 + \dots + I8*K8)}{K0}$$

K0

In@ = Input Variable Connection      n = 1-8

Kn = Constant      n = 0-8

Note: If K0 = 0, the average module will not update its output.

**Function**

**Via the GX Tool**

Click on **PM** in the toolbar, select **Numeric**, then **Average** and position the module (box) on the screen. Make connections between source points and destination points In@, as applicable. Select the module (box) on screen and then **Data** to call up the Data Window. Under numbers 0 through 8, enter appropriate values to complete the calculation.

### ***Via the SX Tool***

An Average Calculation Algorithm of a DX-9100 Controller is assigned to a programmable function module when the value 11 is configured, under **Program Modules**, in PM Item **PMnTYP** (RI.00).

To connect to the Input Variable Connection, enter the source addresses at Alg. Item **In@**, (RI.10 - RI.17).

Enter the values for the constants at Alg. Item **Kn**, (RI.26 - RI.34).

### **High/Low Limits**

The output of the module is limited by the high and low limits. Use these limits to keep the output within a reasonable range in case of the failure of an input.

### ***Via the GX Tool***

Select the average module on screen and then **Data** to call up the Data Window. Enter a value at the **High Limit** and **Low Limit** fields.

If the calculation > high limit, then NCM = high limit

If the calculation < low limit, then NCM = low limit

### ***Via the SX Tool***

The low limit value is entered under **Program Modules** at Alg. Item **LOL** (RI.37) and the high limit at Alg. Item **HIL** (RI.36).

### **Notes**

1. On the SX Tool, the output of the algorithm can be seen under **Program Modules** at Alg. Item **NCM** (RI.60).
2. The logical status of the algorithm can be seen on the SX Tool under **Program Modules** at PM Item **PMnST** (RI.72), with the following bit structure:  

|        |     |                                    |
|--------|-----|------------------------------------|
| X1 = 1 | NML | Calculated Output is at Low Limit  |
| X2 = 1 | NMH | Calculated Output is at High Limit |
3. The module can be put in Hold mode by entering the value 1 in Alg. Item **HLD** (RI.70) bit X1. (This can only be done via the PLC or SX Tool.) Its numeric output (NCM) can be modified in the Hold mode by a BAS or SX Tool.
4. As the numeric output cannot be read at the DX front panel, it is recommended that this algorithm is used in the higher PM numbers, reserving the lower PM numbers for algorithms that can be displayed.

Status Items can be used as logic (digital) connections using the GX Tool or SX Tool.

## GX Labels

### Source Points (Outputs)

- PMnHLD** A 1 when the program module is in the Hold mode, being overridden by the SX Tool or a BAS.
- PMnNCM** The calculation result of a numeric module.
- PMnNMH** A 1 when the calculated output is equal to or greater than the *numeric module high* limit.
- PMnNML** A 1 when the calculated output is less than or equal to the *numeric module low* limit.

### Destination Points (Inputs)

- In@** *Analog input* connections to a programmable module.

---

## Algorithm 12 - Minimum Select

The Minimum Select algorithm selects the minimum value of up to eight input variables.

Each input may be weighted with a constant K. If an input is not connected, the corresponding variable is automatically excluded from the calculation. If one of the inputs is required to be a constant, connect an analog constant (ACO).

$$K0 + \text{MIN.} (I1 * K1, I2 * K2, \dots, I8 * K8)$$

In@ = Input Variable Connection      n = 1-8

Kn = Constant      n = 0-8

## Function

### Via the GX Tool

Click on **PM** in the toolbar, select **Numeric**, then **Minimum** and position the module (box) on the screen. Make connections between source points and destination points In@ as applicable. Select the module (box) on screen and then **Data** to call up the Data Window. Under numbers 0 through 8, enter appropriate values to complete the calculation.

### Via the SX Tool

This algorithm is assigned to a programmable function module when the value 12 is configured in PM Item **PMnTYP** (RI.00).

To connect to the Input Variable Connection, enter the source addresses at Alg. Item **In@**, (RI.10 - RI.17).

Enter the values for constants at Alg. Item **Kn**, (RI.26-RI.34).

## High/Low Limits

The output of the module is limited by the high and low limits. Use these limits to keep the output within a reasonable range in case of the failure of an input.

### ***Via the GX Tool***

Select the minimum module on screen and then **Data** to call up the Data Window. Then enter the appropriate values in the **High Limit** and **Low Limit** fields.

If the calculation > high limit, then NCM = high limit

If the calculation < low limit, then NCM = low limit

### ***Via the SX Tool***

The low limit value is entered under **Program Modules** at Alg. Item **LOL** (RI.37) and the high limit at Alg. Item **HIL** (RI.36).

## **Notes**

1. On the SX Tool, the output of the algorithm can be seen under **Program Modules** at Alg. Item **NCM** (RI.60).
2. The logical status of the algorithm can be seen under **Program Modules** on the SX Tool at PM Item **PMnST** (RI.72) with following bit structure:  
X1 = 1 NML Calculated Output is at Low Limit  
X2 = 1 NMH Calculated Output is at High Limit
3. The module can be put in Hold mode by entering the value 1 in PM Item **PMnHDC** (RI.70) at bit X1. (This can only be done via the PLC or SX Tool.) Its numeric output (NCM) can be modified in the Hold mode by a BAS or SX Tool.
4. As the minimum select output cannot be read at the DX front panel, it is recommended that this algorithm is used in the higher PM numbers, reserving the lower PM numbers for algorithms that can be displayed.

## **GX Labels**

### ***Source Points (Outputs)***

- PMnHLD** A 1 when the program module is in the Hold mode, being overridden by the SX Tool or a BAS.
- PMnNCM** The calculation result of a *numeric module*.
- PMnNMH** A 1 when the calculated output is equal to or greater than the *numeric module high* limit.
- PMnNML** A 1 when the calculated output is less than or equal to the *numeric module low* limit.

### ***Destination Points (Inputs)***

- In@** *Analog input* connections to a programmable module.

---

**Algorithm 13 -  
Maximum  
Select**

The Maximum Select algorithm selects the maximum values of up to eight input variables.

Each input may be weighted with a constant K. If an input is not connected, the corresponding variable is automatically excluded from the calculation. If one of the inputs is required to be a constant, connect an analog constant (ACO).

$K0 + \text{MAX.} (I1 * K1, I2 * K2, \dots, I8 * K8)$

In@ = Input Variable Connection      n = 1-8

Kn = Constant                              n = 0-8

**Function**

***Via the GX Tool***

Click on **PM** in the toolbar, select **Numeric**, then **Maximum** and position the module (box) on the screen. Make connections between source points and destination points In@, as applicable. Select the module (box) on screen and then **Data** to call up the Data Window. Under numbers 0 through 8, enter appropriate values to complete the calculation.

***Via the SX Tool***

This algorithm is assigned to a programmable function module when the value 13 is configured in PM Item **PMnTYP** (RI.00).

To connect to the Input Variable Connection, enter the source addresses at Alg. Item **In@**, (RI.10-RI.17).

Enter the values for the constants at Alg. Item **Kn**, (RI.26-RI.34).

**High/Low Limits**

The output of the module is limited by the high and low limits. Use these limits to keep the output within a reasonable range in case of the failure of an input.

***Via the GX Tool***

Select the maximum module on screen and then **Data** to call up the Data Window. Then enter the appropriate values in the **High Limit** and **Low Limit** fields.

If the calculation > high limit, then NCM = high limit

If the calculation < low limit, then NCM = low limit

***Via the SX Tool***

The module output can be limited by a low limit value entered at Alg. Item **LOL** (RI.37) and a high limit at Alg. Item **HIL** (RI.36).

## Notes

1. On the SX Tool, the output of the algorithm can be seen under **Program Modules** at Alg. Item **NCM** (RI.60).
2. The logical status of the algorithm can be seen on the SX Tool under **Program Modules** at PM Item **PMnST** (RI.72) with following bit structure:  
X1 = 1      NML      Calculated Output is at Low Limit.  
X2 = 1      NMH      Calculated Output is at High Limit.
3. The module can be put in Hold mode by entering the value 1 in PM Item **PMnHDC** (RI.70) bit X1. (This can only be done via the PLC or SX Tool.) Its numeric output (NCM) can be modified in the Hold mode by a BAS or SX Tool.
4. As the maximum select output cannot be read at the DX front panel, it is recommended that this algorithm is used in the higher PM numbers, reserving the lower PM numbers for algorithms that can be displayed.

Status Items can be used as logic (digital) connections using the GX Tool or SX Tool.

## GX Labels

### **Source Points (Outputs)**

- PMnHLD**    A 1 when the program module is in the Hold mode, being overridden by the SX Tool or a BAS.
- PMnNCM**    The calculation result of a *numeric module*.
- PMnNMH**    A 1 when the calculated output is equal to or greater than the *numeric module high* limit.
- PMnNML**    A 1 when the calculated output is less than or equal to the *numeric module low* limit.

### **Destination Points (Inputs)**

- In@**    *Analog input* connections to a programmable module.



---

**Algorithm 14 -  
Psychrometric  
Calculation °C**

Note: Only one Programmable Module within a DX controller may be configured as Algorithm 14 or 15.

This Psychrometric algorithm provides two calculation channels, each with an output that is a function of two inputs, one representing humidity, and the other temperature.

**Function*****Via the GX Tool***

Click on **PM** in the toolbar, select **Numeric**, then **Psychrometric** and position the module (box) on the screen. Select the module and then **Data** to call up the Data Window. In the **FUNCTION TYPE** fields, enter a value describing the type of each of the two channels as follows:

- 0 = Disabled
- 1 = Enthalpy calculation
- 2 = Wet bulb calculation (Channel 1 only)
- 3 = Dew point calculation (Channel 1 only)

***Via the SX Tool***

This algorithm is assigned to a programmable function module when the value 14 is configured in PM Item **PMnTYP** (RI.00). You must first define the function of each channel of the algorithm. Select Alg. Items **FUN1** (RI.02) or **FUN2** (RI.03) and define them as follows:

- X2X1 = 00 Disabled
- X2X1 = 01 Enthalpy calculation KJ/Kg
- X2X1 = 10 Wet Bulb calculation (Channel 1 only)
- X2X1 = 11 Dew Point calculation(Channel 1 only)

**Humidity and  
Temperature**

Next, define the analog input variables:

***Via the GX Tool***

Make connections between the source points and the destination points TEMP1@, HUMID1@, TEMP2@, and HUMID2@ as applicable for:

- Temperature Source Channel 1
- Relative Humidity Source Channel 1
- Temperature Source Channel 2
- Relative Humidity Source Channel 2

***Via the SX Tool***

TM1@ = Input variable connection for temperature value  
(T) - Channel 1 (RI.10)

RH1@ = Input variable connection for relative humidity value  
(F) - Channel 1 (RI.11)

TM2@ = Input variable connection for temperature value  
(T) - Channel 2 (RI.12)

RH2@ = Input variable connection for relative humidity value  
(F) - Channel 2 (RI.13)

**Atmospheric  
Pressure**

***Via the GX Tool***

Select the psychrometric module and then **Data** to call up the Data Window. At the **Atm. Press. no. 1 (mbar)** and **Atm. Press no. 2 (mbar)** fields, enter the atmospheric pressure (mbar) appropriate for your area.

***Via the SX Tool***

The atmospheric pressure (in mbar) can be specified for each channel at Alg. Item **ATP1** (RI.38) and **ATP2** (RI.55).

**High/Low Limits**

The output of the module is limited by the high and low limits. Use these limits to keep the output within a reasonable range in case of the failure of an input.

***Via the GX Tool***

Select the psychrometric module and then **Data** to call up the Data Window. Enter values in the **High Limit** and **Low Limit** fields.

If the calculation > high limit, then NCM = high limit

If the calculation < low limit, then NCM = low limit

***Via the SX Tool***

The module output can be limited by a low limit value entered at Alg. Item **LOL** (RI.37 and 54) and a high limit at Alg. Item **HIL** (RI.36 and 53).

## Notes

1. On the SX Tool, the output of each channel can be seen under **Program Modules** at Alg. Item **NCM1** (RI.60) and **NCM2** (RI.61).
2. The logic status of each channel can be seen on the SX Tool under **Program Modules** at PM Item **PMnST** (RI.72), with following bit structure:  
X1 = 1 NML1 Calculated Output is at Low Limit - Channel 1  
X2 = 1 NMH1 Calculated Output is at High Limit - Channel 1  
X3 = 1 NML2 Calculated Output is at Low Limit - Channel 2  
X4 = 1 NMH2 Calculated Output is at High Limit - Channel 2
3. Status Items can be used as logic (digital) connections using the GX Tool or SX Tool.
4. Channel 2 is only available on DX-9100 Version 1.1 or later, and provides only an enthalpy calculation.
5. The module channels can be put in Hold mode by entering the value 1 in PM Item **PMnHDC** (RI.70), HLD1 at bit X1 for Channel 1, HLD2 at bit X2 for Channel 2. (This can only be done via the SX Tool.) Its numeric outputs (NCM1 and NCM2) can be modified in the Hold mode.
6. As the numeric output cannot be read at the DX front panel, it is recommended that this algorithm is used in the higher PM numbers, reserving the lower PM numbers for algorithms that can be displayed.
7. Only one Programmable Module within a DX controller may be configured as Algorithm 14 or 15.

## GX Labels

### Source Points (Outputs)

- PMnHLDm** A 1 when the channel of the program module has been overridden (in hold) from an SX service module or a BAS.
- PMnNCMm** The calculation result of a channel of a *numeric module*.
- PMnNMHm** A 1 when the psychrometric *numeric module* output is equal to or greater than the *high* limit of the channel.
- PMnNMLm** A 1 when the psychrometric *numeric module* output is less than or equal to the *low* limit of the channel.

### Destination Points (Inputs)

- HUMIDn@** The *relative humidity* sensor connections for psychrometric calculations.
- TEMPn@** The *temperature* sensor connections for psychrometric calculations.

---

**Algorithm 15 -  
Psychrometric  
Calculation °F**

Note: Only one programmable module within a DX controller may be configured as Algorithm 14 or 15.

This Psychrometric algorithm provides two calculation channels, each with an output that is a function of two inputs, one representing humidity, and the other temperature.

**Function*****Via the GX Tool***

Click on **PM** in the toolbar, select **Numeric**, then **Psychrometric**, and position the module (box) on the screen. Select the module and then **Data** to call up the Data Window. In the **Function Type** fields, enter a value describing the type of each of the two channels as follows:

- 0 = Disabled
- 1 = Enthalpy calculation
- 2 = Wet bulb calculation (Channel 1 only)
- 3 = Dew point calculation (Channel 1 only)

***Via the SX Tool***

This algorithm is assigned to a programmable function module when the value 15 is configured in PM Item **PMnTYP** (RI.00). You must first define the function of each channel of the algorithm. Select Alg. Items **FUN1** (RI.02) or **FUN2** (RI.03) and define them as follows:

- X2X1 = 00      Disabled
- X2X1 = 01      Enthalpy calculation Btu/lb
- X2X1 = 10      Wet Bulb calculation °F (Channel 1 only)
- X2X1 = 11      Dew Point calculation °F (Channel 1 only)

**Humidity and  
Temperature**

Next, define the analog input variables:

***Via the GX Tool***

Make connections between the source points and the destination points TEMP1@, HUMID1@, TEMP2@, and HUMID2@ as applicable for:

- Temperature Source Channel 1
- Relative Humidity Source Channel 1
- Temperature Source Channel 2
- Relative Humidity Source Channel 2

***Via the SX Tool***

- TM1@ = Input variable connection for temperature value Channel 1 (RI.10)
- RH1@ = Input variable connection for relative humidity value Channel 1 (RI.11)
- TM2@ = Input variable connection for temperature value Channel 2 (RI.12)
- RH2@ = Input variable connection for relative humidity value Channel 2 (RI.13)

**Atmospheric Pressure**

***Via the GX Tool***

Select the psychrometric module and then **Data** to call up the Data Window. At the **Atm. Press. no. 1 (mbar)** and **Atm. Press no. 2 (mbar)** fields, enter the atmospheric pressure (mbar) appropriate for your area.

***Via the SX Tool***

The atmospheric pressure (in mbar) can be specified for each channel at Alg. Item **ATP1** (RI.38) and **ATP2** (RI.55).

Notes: Standard Sea Level barometric pressure is 1000 mbar or 29.92 in. HG. To convert barometric pressure from inches of mercury (in. HG) to mbar, use this formula:

$$\text{Pressure (mbar)} = 33.42 \times \text{Pressure (in. HG)}$$

**High/Low Limits**

The output of the module is limited by the high and low limits. Use these limits to keep the output within a reasonable range in case of the failure of an input.

***Via the GX Tool***

Select the psychrometric module and then **Data** to call up the Data Window. Enter values in the **High Limit** and **Low Limit** fields.

If the calculation > high limit, then NCM = high limit.

If the calculation < low limit, then NCM = low limit.

***Via the SX Tool***

The module output can be limited by a low limit value entered at Alg. Item **LOL** (RI.37 and 54) and a high limit at Alg. Item **HIL** (RI.36 and 53).

## Notes

1. On the SX Tool, the output of each channel can be seen under **Program Modules** at Alg. Item **NCM1** (RI.60) and **NCM2** (RI.61).
2. The logic status of each channel can be seen on the SX Tool under **Program Modules** at PM Item **PMnST** (RI.72), with the following bit structure:
  - X1 = 1 NML1 Calculated Output is at Low Limit - Channel 1
  - X2 = 1 NMH1 Calculated Output is at High Limit - Channel 1
  - X3 = 1 NML2 Calculated Output is at Low Limit - Channel 2
  - X4 = 1 NMH2 Calculated Output is at High Limit - Channel 2
3. Status Items can be used as logic (digital) connections using the GX Tool or SX Tool.
4. Channel 2 is only available on DX-9100 Version 1.1 or later, and provides only an enthalpy calculation.
5. The module channels can be put in Hold mode by entering the value 1 in PM Item **PMnHDC** (RI.70), HLD1 at bit X1 for Channel 1, HLD2 at bit X2 for Channel 2. (This can only be done via the PLC or SX Tool.) Its numeric output (NCM) can be modified in the Hold mode by a BAS or SX Tool.
6. As the numeric output cannot be read at the DX front panel, it is recommended that this algorithm is used in the higher PM numbers, reserving the lower PM numbers for algorithms that can be displayed.
7. Only one programmable module within a DX controller may be configured as Algorithm 14 or 15.

## GX Labels

### **Source Points (Outputs)**

- PMnHLDm** A 1 when the channel of the program module has been overridden (in hold) from an SX service module or a BAS.
- PMnNMHm** A 1 when the psychrometric *numeric module* output is equal to or greater than the *high* limit of the channel.
- PMnNMLm** A 1 when the psychrometric *numeric module* output is less than or equal to the *low* limit of the channel.

### **Destination Points (Inputs)**

- HUMIDn@** The *relative humidity* sensor connections for psychrometric calculations.
- TEMPn@** The *temperature* sensor connections for psychrometric calculations.

---

**Algorithm 16 -  
Line Segment**

The Line Segment Algorithm output is a nonlinear function of the input variable I1 defined on an X,Y plane using up to 17 break points. This is typically used to linearize input from a nonlinear sensor, or for a complex reset schedule.

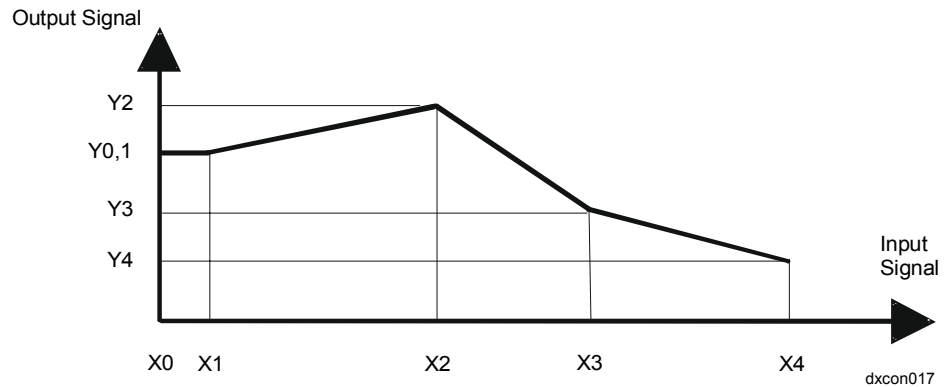

**Figure 15: Line Segment Function**

**Function*****Via the GX Tool***

Click on **PM** in the toolbar, select **Numeric**, then **Segment**, and position the module (box) on the screen. Select the module and then **Data** to call up the Data Window. On pages 1 and 2, enter the X and Y coordinates as required. Make connections between the source point and destination point In@ of the line segment module.

***Via the SX Tool***

This algorithm is assigned to a programmable function module when the value 16 is configured in PM Item **PMnTYP** (RI.00).

I1@ = Input Variable Connection (RI.10)

Break point 0: coordinates X0,Y0

X0 = RI.26, X1 = RI.28 ... X16 = RI.58 (evens)

Y0 = RI.27, X1 = RI.29 ... Y16 = RI.59 (odds)

Break point 16: coordinates X16,Y16

X0 = RI.26, X1 = RI.28 ... X16 = RI.58 (evens)

Y0 = RI.27, X1 = RI.29 ... Y16 = RI.59 (odds)

## Notes

1. On the SX Tool, the output of the algorithm can be seen under **Program Modules** at Alg. Item **NCM (RI.60)**.
2. Coordinates must be defined for the complete range of the input variable (x) so that the output can always be calculated. X values *must* be entered in ascending order and the same number may *not* be entered twice.
3. A line segment module may be chained to the next programmable function module (in numerical sequence) by:

GX Tool: Select the line segment module and then **Data** to call up the Data Window. Go to page 2. At the **Chain (0=N)** field, enter 1 if you need more than 17 break points. Define the next PM as a SEGMENT module where breakpoints X0, Y0 ... X16, Y16 will act as break points X17, Y17 ... X33, Y33 for the Analog Input in the first defined module. No analog input connection is required in the second module.

SX Tool: Set bit X16 in the PM Item **PMnOPT (RI.01)** to 1. In this case, the next programmable function module must be defined as a line segment module where Break Point 0-16 will act a Break Points 17-33 for the input connected at **I1@** in the first module. No connection at **I1@** is required in the second module.

4. The module can be put in Hold mode by entering the value 1 at PM Item **PMnHDC (RI.70)** bit X1. (This can only be done via the PLC or SX Tool.) Its numeric output (NCM) can be modified in the Hold mode by a BAS or SX Tool.
5. As the numeric output cannot be read at the DX front panel, it is recommended that this algorithm is used in the higher PM numbers, reserving the lower PM numbers for algorithms that can be displayed.

## GX Labels

### **Source Points (Outputs)**

**PMnHLD** A 1 when the program module is in the Hold mode, being overridden by the SX Tool or a BAS.

**PMnNCM** The calculation result of a *numeric module*.

### **Destination Points (Inputs)**

**In@** *Analog input* connections to a programmable module.



---

**Algorithm 17 -  
Input Selector**

The Input Selector algorithm selects one of its four analog input connections as its output. The selection is determined by the state of the Digital Inputs 5 and 6.

**Table 3 : Algorithm 17 - Input Selector**

| Input | I5  | I6  | Output              |
|-------|-----|-----|---------------------|
| I1    | Off | Off | $I1 \times K1 + C1$ |
| I2    | On  | Off | $I2 \times K2 + C2$ |
| I3    | Off | On  | $I3 \times K3 + C3$ |
| I4    | On  | On  | $I4 \times K4 + C4$ |

If an analog input **In@** is not connected and is selected by the status of Logical Inputs I5 and I6, the output is not updated and maintains the previously selected output value. It is recommended that each input that can be selected is connected to a numeric Item with a known value. The same numeric Item can be connected to more than one input.

If a logic input is not connected, a value of 0 (Off) is assumed.

**Function****Via the GX Tool**

Click on **PM** in the toolbar, select **Numeric**, then **Select** and position the module (box) on the screen. Select the module and then **Data** to call up the Data Window. Enter the appropriate Kn and Cn values to achieve the desired results. Make connections between source points and destination points In@ in the selector module, as applicable.

**Via the SX Tool**

This algorithm is assigned to a programmable function module when the value 17 is configured in PM Item **PMnTYP** (RI.00).

In@ = Analog Input Variable Connection      n = 1-4 (RI.10 to RI.13)

In@ = Logic Input Variable Connection      n = 5-6 (RI.14 to RI.15)

Cn, Kn = constants      n = 1-4 (RI.26 to RI.33)

Kn (even RI)

Cn (odd RI)

**High/Low Limits**

The output of the module is limited by the high and low limits. Use these limits to keep the output within a reasonable range in case of the failure of an input.

### ***Via the GX Tool***

Click on the select module and then **Data** to call up the Data Window. At the **High Limit** and **Low Limit** fields, set the required limits:

- If the calculation > high limit, then NCM = high limit
- If the calculation < low limit, then NCM = low limit

### ***Via the SX Tool***

The module output can be limited by a low limit value entered at Alg. Item **LOL** (RI.37) and a high limit at Alg. Item **HIL** (RI.36).

## **Notes**

1. On the SX Tool, the output of the algorithm can be seen under **Program Modules** at Alg. Item **NCM** (RI.60).
2. The logical status of the algorithm can be seen on the SX Tool under **Program Modules** at PM Item **PMnST** (RI.72), with following bit structure:  
X1 = 1    NML        Calculated Output at Low Limit  
X2 = 1    NMH        Calculated Output at High Limit  
Status Items can be used as logic (digital) connections using the GX Tool or SX Tool.
3. The module can be put in Hold mode by entering the value 1 at PM Item **PMnHDC**, (RI.70) at bit X1. (This can only be done via the PLC or SX Tool.) Its numeric output (NCM) can be modified in the Hold mode by a BAS or SX Tool.
4. As the numeric output cannot be read at the DX front panel, it is recommended that this algorithm is used in the higher PM numbers, reserving the lower PM numbers for algorithms that can be displayed.

## **GX Labels**

### ***Source Points (Outputs)***

- PMnHLD**    A 1 when the program module is in the Hold mode, being overridden by the SX Tool or a BAS.
- PMnNCM**    The calculation result of a *numeric module*.
- PMnNMH**    A 1 when the calculated output is equal to or greater than the *numeric module high* limit.
- PMnNML**    A 1 when the calculated output is less than or equal to the *numeric module low* limit.

### ***Destination Points (Inputs)***

- In@**        *Input* connections to a programmable module.

---

**Algorithm 18 -  
Calculator**

The Calculator function is an algebraic expression of up to eight input variables. When an input is not connected, a value of 1 is assumed and the corresponding constant (Kn) must be set to the required value. If the denominator is 0, the equation outputs the last reliable calculation.

The equation choices are listed below:

Equation 1 (linear):

$$K0 + \frac{((K1 * I1 + K2 * I2 + K3) * I3 + K4) * I4}{((K5 * I5 + K6 * I6 + K7) * I7 + K8) * I8}$$

Equation 2 (polynomial):

$$K0 + \frac{K1 * I1^3 + K2 * I2^2 + K3 * I3 * (K4 * I4 - K5 * I5) + K6 * \sqrt{I6} + K9}{K7 * I7 + K8 * I8}$$

Equation 2 (as seen in GX):

$$K0 + \frac{K1 * I1^3 + K2 * I2^2 + K3 * I3 * (K4 * I4 - K5 * I5) + K6 * I6^{0.5} + K9}{K7 * I7 + K8 * I8}$$

**Function****Via the GX Tool**

Click on **PM** in the toolbar, select **Numeric**, then **Calculator**, and position the module (box) on the screen. Select the module and then **Data** to call up the Data Window. At the **Eq. (1 or 2)** field, enter the appropriate equation needed.

Enter values for the constants for the desired calculated output. Be especially careful of the order and combinations of inputs and constants.

Make connections between source points and In@ inputs of the Calculator Module, as required.

**Via the SX Tool**

This algorithm assigned to a programmable function module when the value 18 is configured in PM Item **PMnTYP** (RI.00).

The bit structure of the Alg. Item **FUN** (RI.02) defines the function of the algorithm:

X2X1 = 00          Not used

X2X1 = 01          Equation 1

X2X1 = 10          Equation 2

In = Input Variable          n = 1 to 8          (RI.10 to RI.17)

Kn = Constant                  n = 0 to 8/9        (RI.26 to RI.35)

**High/Low Limits**

The output of the module is limited by the high and low limits. Use these limits to keep the output within a reasonable range in case of an input failure.

### ***Via the GX Tool***

Select the calculator module and then **Data** to call up the Data Window. Then make entries in the **High Limit** and **Low Limit** fields.

If the calculation > high limit, then output = high limit

If the calculation < low limit, then output = low limit

### ***Via the SX Tool***

The module output can be limited by a low limit value entered at Alg. Item **LOL** (RI.37) and a high limit at Alg. Item **HIL** (RI.36).

## **Notes**

1. On the SX Tool, the output of the algorithm can be seen under **Program Modules** at Alg. Item **NCM** (RI.60).
2. The logical status of the algorithm can be seen on the SX Tool under **Program Modules** at PM Item **PMnST** (RI.72), with the following bit structure:  

|        |     |                                     |
|--------|-----|-------------------------------------|
| X1 = 1 | NML | Calculated Output is at Low Limit.  |
| X2 = 1 | NMH | Calculated Output is at High Limit. |

Status Items can be used as logic (digital) connections using the GX Tool or SX Tool.
3. The module can be put in Hold mode by entering the value 1 at PM Item **PMnHDC** (RI.70) bit X1. (This can only be done via the PLC or SX Tool.) Its numeric output (NCM) can be modified in the Hold mode by a BAS or SX Tool.
4. As the numeric output cannot be read at the DX front panel, it is recommended that this algorithm is used in the higher PM numbers, reserving the lower PM numbers for algorithms that can be displayed.

## **GX Labels**

### ***Source Points (Outputs)***

- PMnHLD** A 1 when the program module is in the Hold mode, being overridden by the SX Tool or a BAS.
- PMnNCM** The calculation result of a *numeric module*.
- PMnNMH** A 1 when the calculated output is equal to or greater than the *numeric module high* limit.
- PMnNML** A 1 when the calculated output is less than or equal to the *numeric module low* limit.

### ***Destination Points (Inputs)***

- In@** *Analog input* connections to a programmable module.

**Algorithm 19 -  
Timer  
Functions**

The Timer Algorithm provides an eight channel time delay unit. Each channel has two inputs and provides one logic output that can be connected to an output module or used in the PLC module. Each channel provides a numerical output that displays the amount of time remaining until the end of the delay time defined.

**Timers**

**Pulse Type**

The output goes high for a time period  $T$  after an input transition from low to high. Further transitions during the timing cycle will not influence the cycle. A 1 on the reset input forces the output to 0, clearing the time cycle. At the end of the time period, the output will go off whether the input is high or low.

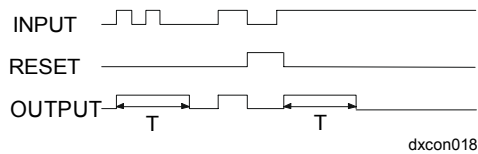

**Figure 16: Pulse Type**

**Retriggerable Pulse**

Similar to above, with the exception that the timing period begins from the last input transition. A 1 on the reset input forces the output to 0, clearing the time cycle.

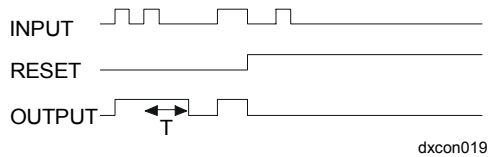

**Figure 17: Retriggerable Pulse**

**On Delay with Memory**

The output goes high after a time period ( $T$ ) from the input going high. If the input is high for a period less than ( $T$ ), the output will never go high. The output goes low only after the reset goes high. A 1 on the reset input forces the output to 0, clearing the time cycle.

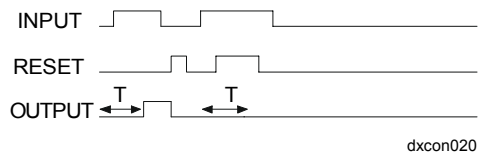

**Figure 18: On Delay with Memory**

### On Delay

The output goes high after a time period (T) from the input going high. If the input is high for a period less than (T), the output will never go high. The output goes low immediately when the input goes low. A 1 on the reset input forces the output to 0, clearing the time cycle.

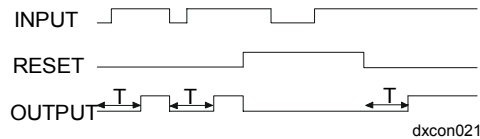

**Figure 19: On Delay**

### Off Delay

The output goes high immediately when the input goes high. The output goes low after a time period (T) from the input going low. If the input goes high during the period less than (T), the output will not go low. A 1 on the reset input forces the output to 0, clearing the time cycle.

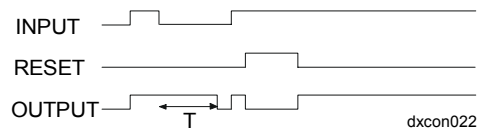

**Figure 20: Off Delay**

### Via the GX Tool

Click on **PM** in the toolbar, select **Numeric**, then **Timer**, and position the module (box) on the screen. Select the module and then **Data** to call up the Data Window. At the **Timer #n type** field, enter the number for the desired timer output action:

- 0 = Disabled
- 1 = Pulse
- 2 = Retriggerable Pulse
- 3 = On delay with memory
- 4 = On delay
- 5 = Off delay

At the **Time Units #n** field, enter a value to determine the time scale:

- 0 = seconds
- 1 = minutes
- 2 = hours

At the **Time Period** field, enter the delay time as a whole number (no decimal) in the units chosen under the **Time Units #n** field. The module will round up or down any decimal value to the nearest whole number.

Make connections between source points and destination points In@ (for input connection) and RSn@ (for reset connection).

Whenever a source point entered at **Reset Connection #n** goes On, the output immediately goes Off and the timer is reset. A reset connection is always required for Timer Type 3.

### ***Via the SX Tool***

A Timer Algorithm is assigned to a programmable function module when the value 19 is configured in PM Item **PMnTYP** (RI.00). The bit structure of the Alg. Item **FUNn** (n = 1-8) (RI.02 to RI.09) defines the function of each channel of the algorithm:

|              |  |         |
|--------------|--|---------|
| X3X2X1 = 000 | Channel Disabled   |         |
| X3X2X1 = 001 | Pulse  |         |
| X3X2X1 = 010 | Retriggerable Pulse  |         |
| X3X2X1 = 011 | On Delay with Memory   |         |
| X3X2X1 = 100 | On Delay   |         |
| X3X2X1 = 101 | Off Delay  |         |
| X6X5 = 00    | Time in seconds  |         |
| X6X5 = 01    | Time in minutes  |         |
| X6X5 = 10    | Time in hours  |         |
| In@ =        | Input Variable Connection for Channel #n<br>(even numbers, RI.10 to RI.24) | n = 1-8 |
| RSn@ =       | Reset Variable Connection for Channel #n<br>(odd numbers, RI.11 to RI.25)  | n = 1-8 |
| Tn =         | Time period Channel #n (0 - 3276)<br>(RI.26 to RI.33)                      | n = 1-8 |
| TIMn =       | Time to end of period Channel #n<br>(RI.60 to RI.67)                       | n = 1-8 |

## Notes

1. Each channel can be put in Hold mode using the SX Tool by entering the value 1 at PM Item **PMnHDC** (n = 1-8), (RI.70); HLD1 = bit X1...HLD8 = bit X8. Its logic output can be modified in the Hold mode.
2. The logical output status of the algorithm can be seen on the SX Tool at PM Item **PMnDO** (RI.71); TDO1 = bit X1...TDO8 = bit X8.
3. A 1 on the reset input always forces the output to 0, clearing the time cycle.
4. Do not modify the time base (seconds, minutes, hours) while the timer is active. Modifying the time period once it has started has no effect until the timer is re-triggered based on type and input. The SX is a good tool to use to see how much time remains on a timer at Item TIMn.
5. As the timer functions cannot be read at the DX front panel, it is recommended that this algorithm is used in the higher PM numbers, reserving the lower PM numbers for algorithms that can be displayed.

## GX Labels

### **Source Points (Outputs)**

- PMnHLDm** A 1 when the channel of the program module has been overridden (in hold) from an SX service module or a BAS.
- PMnTDOM** A 1 when the numeric *timer* channel output is On.
- PMnTIMm** The numeric *timer* module timer value of each channel. It will be 0 when the channel is not triggered or the timer has expired; or it will be the number of seconds (or minutes, or hours) left as the timer decrements.

### **Destination Points (Inputs)**

- In@** *Analog input* connections to a programmable module.
- RSn@** The connection to the *reset* function of a timer module channel (to reset the output).



---

**Algorithm 20 -  
Totalization**

The Totalization module provides an eight channel totalization algorithm. Channels can be configured for Event, Integrator, or Time totalization. In Firmware Version 1.1 or later, an Accumulated Total option is available.

**Event Counter**

The Event Counter performs the counting of binary transitions from 0 to 1 of a logic source connected to the input of the channel. The number of transitions is scaled to generate a numeric output of total transitions. The output is incremented whenever the number of the transitions counted is equal to the value set in the scaling factor field. The input connection to an Event Counter must be a logic type.

**Integrator**

The Integrator performs the integration of the value of an analog variable connected to the input of the channel. The integration rate is determined by the time constant (FTC) (in minutes) and the result read as a numeric output. In other words, the Integrator will count up to the value of the numerical input in a period of time equal to the time constant (assuming that the input remains constant during this period). For example, if the input is equal to 30 and the time constant is five minutes, the output will count up to 30 in five minutes (at a rate of 0.1 per second), to 60 in ten minutes, and so on, until it reaches the full scale limit.

To integrate kW into kWh, set the time constant to 60 minutes (one hour).

If the input is in gallons per minute, a time constant of one minute would give a total in gallons. If the actual rate was, for example, 100 gallons per minute, in one hour 6,000 gallons would be totalized, and in one day 144,000 gallons. Since the totalized output only displays to 9999, the time constant could be used to slow down the totalization. By setting the time constant to 1000, the totalization units would be gallons x 1000.

If the input is in liters per second, a time constant of 1/60 (=0.0167) is required to totalize in liters, as one second equals 1/60 minutes. As explained above, this may result in very high numbers very quickly, so it could be slowed down by setting the time constant to 1000 x 0.0167 (=16.67) and totalizing in liters x 1000 (=cubic meters).

As the totalization module has a floating point output, resolution is lost beyond a value of 2,047. (Refer to the *Configuration Tools - Entering Values* section earlier in this document.) Therefore it is necessary to totalize integrated values by using either a cascade of one Integrator and one or more Event Counters, each with a full scale limit of 1,000 and using the Full Scale Limit flag (FSL) to reset the counters in sequence, or by using the Accumulated Total option. When this option is selected, the Accumulated Total for the channel will be incremented whenever the output reaches its full scale limit, and the output will automatically be reset. The Accumulated Total records the number of times the Full Scale has been reached.

The input connection to an Integrator must be analog only.

## Time Counter

The Time Counter function counts the time that the source point is in a 1 condition at a rate entered in the time constant (in seconds). The output is the totalized time value. Typically the time constant would be set at 60 seconds for runtime in minutes or 3600 seconds for runtime in hours. The Accumulated Total option may also be used for a Time Counter if a total of greater than 2047 is required.

### ***Via the GX Tool***

Click on **PM** in the toolbar, select **Totalization** and position the module (box) on the screen. Select the module and then **Data** to call up the Data Window. In the **TOTALIZATION n TYPE** field, enter a value to assign the required function for each channel.

- 0 = Disabled
- 1 = Event Counter
- 2 = Integrator
- 3 = Time Counter

Make connections between source and destination points In@ (for input connection) and RSn@ (for reset connection).

### ***Via SX Tool***

This algorithm is assigned to a programmable function module when the value 20 is configured in PM Item **PMnTYP** (RI.00). The bit structure of the Alg. Item **FUNn** (n = 1-8), (RI.02 to RI.09) defines the function of each channel of the algorithm:

- X2X1 = 00 Not used
- X2X1 = 01 Event Counter of a digital input
- X2X1 = 10 Integrator of an analog input
- X2X1 = 11 Time Counter of a digital input
- In@ = Input Variable Connection for Channel #n n = 1-8  
(even numbers, RI.10 to RI.24)
- RSn@ = Reset Variable Connection for Channel #n n = 1-8  
(odd numbers, RI.11 to RI.25)

**Full Scale Limit****Via GX Tool**

At the **Full Scale Limit #n** field, enter the required value. When the output reaches this value, the output will hold there until reset, or, if the Accumulated Total option is selected, the output will automatically be reset to 0 and the accumulated total for this channel will be incremented.

**Via SX Tool**

The Full Scale Limits are entered at Alg. Items FSLn (RI.26 to RI.33), where n is equal to the channel number (1-8).

**Scale/Time Constant****Via GX Tool**

At the **Scale/Time Const #n** field, enter the required value. For the Integrator, the value is in minutes. For Event, it is the number of On/Off transitions to count as one event. For Runtime, the value is in seconds; 60 would be runtime in minutes, 3600 would be runtime in hours.

Note: Changing values after counts are already there will alter the totals accordingly. For example, if the Event scale was at 1 with 20 counts, and the Event scale was changed to 2, the counts would equal 10.

**Via SX Tool**

The Scaling Factors/Time Constants are entered at Alg. Items FTCn (RI.34 to RI.41), where n is equal to the channel number (1-8).

**Increment Accumulated Total Function****Via GX Tool**

At the **Incrmnt ACC. #n (0=N)** field, enter 1 or 0 (DX-9100 Version 1.1 or later.) This is the Increment Accumulated Total function. It is recommended that the Full Scale Limit should be set to 1,000, 100, or 10. Setting Increment ACC to 1 will enable the counter to count the number of times that the full scale limit is reached. The Accumulated Total is a 4-byte integer and can store up to 9,999,999 counts (32,767 when the Metasys option has been selected, under GLOBAL, Counter Type field).

**Via SX Tool**

The Increment Accumulated Total function is defined by setting bit X8 in Alg. Item FUNn (n=1-8) (RI.02 to RI.09) as follows:

X8 = 1    Increment ACTn and reset TOTn when FSSn = 1 (n=1-8)  
(Version 1.1 or later)

When bit X8 is set to 0 (default) and the output reaches the Full Scale Limit FSL<sub>n</sub>, the algorithm function is frozen until reset. When bit X8 is set to 1 and the output reaches the Full Scale Limit **FSL<sub>n</sub>**, the totalized output is automatically reset to 0 and the Alg. Item **ACT<sub>n</sub>** (RI.73 to RI.80) is incremented by one count.

## Notes

1. You can read and modify the totalized values from the DX front panel. See *Display Panel and Keypads* in the *DX-9100 Extended Digital Controller Technical Bulletin (LIT-6364020)* in *FAN 636.4* or *1628.4*.
2. On the SX Tool, the output of each channel can be seen at Alg. Item TOT<sub>n</sub> (RI.60 to RI.67), and the Accumulated Total can be seen at Alg. Item ACT<sub>n</sub> (RI.73 to RI.80).
3. On the SX Tool, each channel can be put in Hold mode by entering the value 1 at PM Item **PM<sub>n</sub>HDC** (n = 1-8) (RI.70); HLD1 is bit X1, HLD8 is bit X8. Its numeric (TOT<sub>n</sub>) output can be modified in the Hold mode by a BAS.
4. The Full Scale Status of Channel #n can be seen at PM Item **PM<sub>n</sub>ST** (n = 1-8) (RI.72); FSS1 is bit X1...FSS8 is bit X8. These logic variables can be used to signal an alarm or initiate a dial-up to notify an operator that a limit has been reached.
5. A 1 on the Reset input forces the totalized output and the accumulated total to 0.

## GX Labels

### Source Points (Outputs)

- PM<sub>n</sub>FSS<sub>m</sub>** A 1 when the *output* of a channel of a totalization module is at its full scale limit.
- PM<sub>n</sub>HLD<sub>m</sub>** A 1 when the channel of the program module has been overridden (in hold) from an SX service module or a BAS.
- PM<sub>n</sub>TOT<sub>m</sub>** The *totalized* value of a totalization module channel; the number of events, runtime, or integration value.

### Destination Points (Inputs)

- In@** *Analog input* connections to a programmable module.
- RS<sub>n</sub>@** The connection to the *reset* function of a totalization module channel (to reset to 0 and re-start).



Equality Status: Logic Status

$LS_n = 1$  when  $SP_n - DF_n < In < SP_n + DF_n$

$LS_n = 0$  when  $In < SP_n - DF_n$  or  
 $In > SP_n + DF_n$

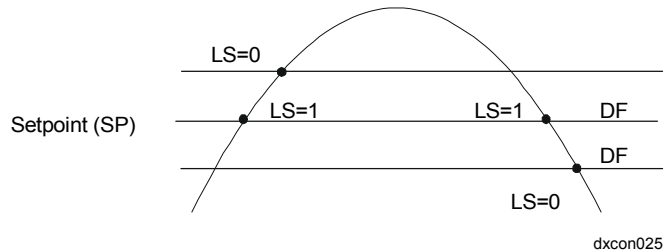

**Figure 23: Comparator Equality Status Function Example**

Dynamic Status: Logic Status

$LS_n = 1$  when  $In$  is changing more than the value of the differential ( $DF_n$ ) in one second.

$LS_n = 0$  when  $In$  is changing less than the value of the differential ( $DF_n$ ) in one second.

## Function

### *Via the GX Tool*

Click on **PM** in the toolbar, select **Numeric**, then **Comparator** and position the module (box) on the screen. Select the module and then **Data** to call up the Data Window. At the **CHANNEL TYPE #n** field, enter the value corresponding to the desired function:

- 0 = Channel Disabled
- 1 = High Limit
- 2 = Low Limit
- 3 = Equality Status
- 4 = Dynamic Status

Then enter the Setpoint and Differential values for each channel.

At the **Differential #n** field, enter a fixed value. The Setpoint #n may be a fixed value or can be sourced from a numerical Item. Make connections between the source points and destination points  $In@$  and  $SPn@$ , as applicable.

### ***Via the SX Tool***

This algorithm is assigned to a programmable function module when the value 21 is configured in PM Item **PMnTYP** (RI.00). The bit structure of the Alg. Item **FUNn** (n = 1-8) (RI.02 to RI.09) defines the function of each channel of the algorithm:

X3X2X1 = 000      Channel Disabled

X3X2X1 = 001      High Limit

X3X2X1 = 010      Low Limit

X3X2X1 = 011      Equality Status

X3X2X1 = 100      Dynamic Status

In@ = Analog Input Variable Connection for Channel #n      n = 1-8  
(even numbers, RI.10 to RI.24)

SPn@ = Setpoint value Variable Connection for Channel #n      n = 1-8  
(odd numbers, RI.11 to RI.25)

NCMn = Deviation (In - SPn) - Channel #n      n = 1-8  
(RI.60 to RI.67)

SPn = Setpoint value (If SPn@ not connected) Channel #n      n = 1-8  
(even numbers, RI.26 to RI.40)

DFn = Differential Channel #n      n = 1-8  
(odd numbers, RI.27 to RI.41)

### **Notes**

1. If there is no connection to Item **SPn@**, the module uses the setpoint value in Item **SPn** (even numbers, RI.26 to RI.40).
2. On the SX Tool, each channel can be put in Hold mode by entering the value 1 at PM Item **PMnHDC** (RI.70); HLD1 = bit X1...HLD8 = bit X8. Its numeric output (NCMn) can be modified in the Hold mode by a BAS.
3. The Logic Status of Channel #n can be seen at PM Item **PMnST** (RI.72); LS1 = bit X1...LS8 = bit X8.
4. As the numeric output cannot be read at the DX front panel, it is recommended that this algorithm is used in the higher PM numbers, reserving the lower PM numbers for algorithms that can be displayed.

## GX Labels

### Source Points (Outputs)

**PMnHLDm** A 1 when the channel of the program module has been overridden (in hold) from an SX service module or a BAS.

**PMnLSm** A 1 when the comparator module channel is at its comparison true *logic state*.

**PMnNCMm** The calculation result of a channel of a *numeric module*.

### Destination Points (Inputs)

**In@** *Analog input* connections to a programmable module.

**SPn@** A setpoint connection for a comparator channel if a remote setpoint is desired, otherwise the entered value for the setpoint will be used.

---

## Algorithm 22 - Sequencer

A Sequencer Algorithm provides the control of one to eight logic outputs as a function of the value of an analog source variable or two logic source variables (increase and decrease signals) and the state of eight logic (disable) inputs.

A sequencer module may be chained to the next module in numerical sequence to provide control of 16 logic outputs in 1 sequencer algorithm. Each logic output represents one stage of the controlled load.

The logic outputs or stages can be grouped into sets, each set having a definable number of stages.

The sequencer module is used to control multi-stage equipment, maintaining minimum On/Off times, interstage delays, and sequencing loads.

The sequencer can be interfaced to the PLC module and to other programmable function modules that provide control, interlocking, and alarm capability.

## Function

### Via the GX Tool

Click on **PM** in the toolbar and select **Sequencer**.

For a Binary Code sequencer (see *Configuring the Options*), click on **PM** in the toolbar and select **Binary Sequencer**.

### Via the SX Tool

This algorithm is assigned to a programmable function module when value 22 is configured in PM Item **PMnTYP** (RI.00).



## Configuring the Options

### Assumptions

The following configuration examples are based on these assumptions:

- Stg #1 first of = 3
- LdFctrStg#n = 33
- Load Differential [%] = 33
- Retroactive [0 = N] = 1]

### Step Mode

The output stages are controlled in sequence according to the *last on, first off* principle. For example, a three stage sequencer controls the output stages in the following sequence: (0 = Off, 1 = On)

**Table 4: Step Mode**

|         | Load Percent |    |    |     |    |    |   |
|---------|--------------|----|----|-----|----|----|---|
|         | 0            | 33 | 66 | 100 | 66 | 33 | 0 |
| Stage 1 | 0            | 1  | 1  | 1   | 1  | 1  | 0 |
| Stage 2 | 0            | 0  | 1  | 1   | 1  | 0  | 0 |
| Stage 3 | 0            | 0  | 0  | 1   | 0  | 0  | 0 |

### Sequential Mode

The sets are controlled in sequence according to the *first on, first off* principle. Stages within a set are controlled to the *last on, first off* principle (like Step mode). For example, a three set sequencer controls the output sets in the following sequence: (0 = Off, 1 = On)

**Table 5: Sequential Mode**

|       | Load Percent |    |    |     |    |    |   |
|-------|--------------|----|----|-----|----|----|---|
|       | 0            | 33 | 66 | 100 | 66 | 33 | 0 |
| Set 1 | 0            | 1  | 1  | 1   | 0  | 0  | 0 |
| Set 2 | 0            | 0  | 1  | 1   | 1  | 0  | 0 |
| Set 3 | 0            | 0  | 0  | 1   | 1  | 1  | 0 |

### Equal Runtime

The On time of the first output stage of each set is totalized. In case of an increase of load requiring the activation of a new set, the set with the lowest On time will be switched on. In case of a decrease of load requiring the switching off of a stage in a set at full load, the set with the highest On time will be switched off first. Stages within a set are controlled to the *last on, first off* principle (Step mode). For example, a three set sequencer controls the output sets in the following sequence: (0 = Off, 1 = On).

**Table 6: Runtime**

|              | Increasing Load (Percent) |   |    |    | Decreasing Load (Percent) |           |     |    |    |   |
|--------------|---------------------------|---|----|----|---------------------------|-----------|-----|----|----|---|
|              | Runtime                   | 0 | 33 | 66 | 100                       | Runtime   | 100 | 66 | 33 | 0 |
| <b>Set 1</b> | 90 hours                  | 0 | 0  | 0  | 1                         | 95 hours  | 1   | 1  | 1  | 0 |
| <b>Set 2</b> | 40 hours                  | 0 | 1  | 1  | 1                         | 110 hours | 1   | 0  | 0  | 0 |
| <b>Set 3</b> | 65 hours                  | 0 | 0  | 1  | 1                         | 99 hours  | 1   | 1  | 0  | 0 |

As the load increases, the set with a runtime of 40 hours starts first. As the load decreases, the set with a runtime of 110 hours stops first.

### **Binary Code**

The output stages must form one set and are controlled in sequence according to a binary code principle. For example, a three stage sequencer controls the output stages in the following sequence:

**Table 7: Binary Code**

| Stage           | 0 kW | 1 kW | 2 kW | 3 kW | 4 kW | 5 kW | 6 kW | 7 kW |
|-----------------|------|------|------|------|------|------|------|------|
| <b>1 (1 kW)</b> | 0    | 1    | 0    | 1    | 0    | 1    | 0    | 1    |
| <b>2 (2 kW)</b> | 0    | 0    | 1    | 1    | 0    | 0    | 1    | 1    |
| <b>3 (4 kW)</b> | 0    | 0    | 0    | 0    | 1    | 1    | 1    | 1    |

As load % increases ----->

Notes: The Binary Code mode is intended for use only with electric heaters or other nonmechanical devices.

The binary code sequencer will always select the appropriate stage combination for the requested output, with a stage delay between the changing of a stage combination. The sequencer will not step through successive combinations when a large change in requested output occurs.

When the Binary Code mode is selected, the algorithm will automatically assign load factors that will summate to 100%, and the differential will be set to 20% of the minimum (first stage) load factor with a maximum of 3% of the total load.

### ***Via the GX Tool***

Select the sequencer module and then **Data** to call up the Data Window. At the **Sequen. Module** mode field, enter the value that defines the desired mode:

- 0 = Disable
- 1 = Step mode
- 2 = Sequential
- 3 = Not Applicable (Use *Binary Sequence* for Binary Code)
- 4 = Equal Runtime

(For the binary sequence module, the Sequence Module mode is automatically set to binary code.)

### ***Via the SX Tool***

The Algorithm mode is defined by bits X3 X2 X1 of PM Item **PMnOPT** (RI.01), as follows:

|                |               |
|----------------|---------------|
| X3 X2 X1 = 000 | Disabled      |
| X3 X2 X1 = 001 | Step Mode     |
| X3 X2 X1 = 010 | Sequential    |
| X3 X2 X1 = 011 | Binary Code   |
| X3 X2 X1 = 100 | Equal Runtime |

## **Analog Input Connection**

The analog control input determines the required output in percent of the total output, and would normally be the output of a PID module. The percent load factor for each output stage and the differential must be specified (see *Configuring the Load Factors and Differential* in this section), except for a Binary Code sequence, where the load factors are calculated automatically by the module.

### ***Via the GX Tool***

Make a connection between the analog source point and the INC@ destination point, which also represents the analog input connection, in the sequencer module.

### ***Via the SX Tool***

Set bit X8 of PM Item **PMnOPT** (RI.01) to 0 to define the input as analog. Connect the analog source point at Alg. Item **INC@** (RI.18).

## Digital Input Connection

One digital control input increases the required output value and a second input decreases the output value. When digital inputs are connected, a Full Load Ramp Time (sec.) determines the time that the Increase Input must be On for the requested output to change from 0 to 100% or the Decrease Input must be On for the requested output to change from 100 to 0%.

### *Via the GX Tool*

Make a connection between the digital source point and the INC@ destination point. Also make a connection from the Decrease digital source point to the DEC@ destination point.

Select the sequencer or binary sequencer module and then **Data** to call up the Data Window. Go to page 2. At the **Full Load Rmp (sec)** field, enter the value corresponding to the desired Full Load Ramp Time action.

### *Via the SX Tool*

Assign the input type by setting bit X8 of PM Item **PMnOPT** (RI.01) to 1 to define the input as digital. Enter the increase source point at Alg. Item **INC@** (RI.18). Enter the decrease source point at Alg. Item **DEC@** (RI.19). Set the Full Load Ramp Time at Alg. Item **FLR** (RI.44).

## Sequencer Control

The sequencer control is either proactive or retroactive.

### *Proactive*

The first stage selected by the sequencer is always On unless the Fast Step Down input is active. The second stage is switched On when the first stage is at its load factor, the third stage when the second stage is at its load factor, and so on. This mode is normally required for equipment with its own modulating control, for example, centrifugal refrigeration compressors.

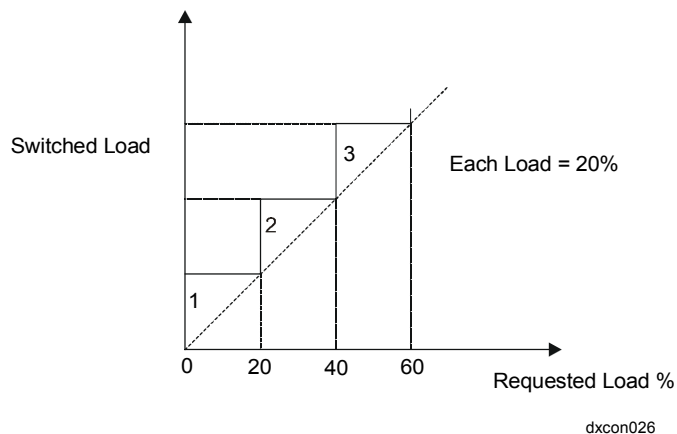

**Figure 24: Proactive Sequencer**

### **Retroactive**

The first stage is not switched On until the required load is equal to its load factor. Each subsequent stage is not switched until its load factor is required. This mode is normally required for equipment without modulating control, for the control of electric heaters, for example.

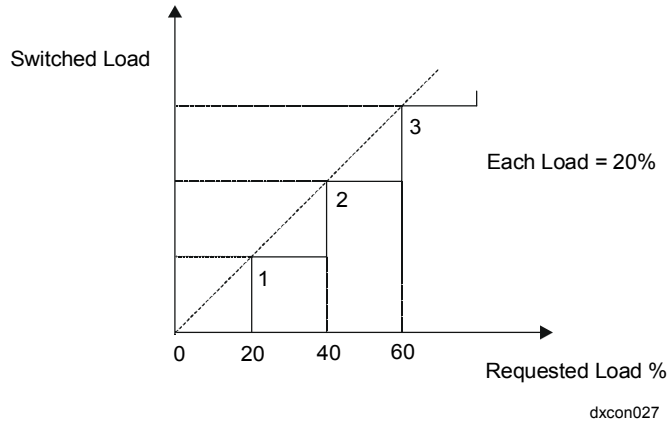

**Figure 25: Retroactive Sequencer Control**

### **Via the GX Tool**

Select the sequencer module and then **Data** to call up the Data Window. Go to page 2. At the **Retroactive (0=N)** field, enter 0 for Proactive, or 1 for Retroactive. (A binary sequencer module is automatically set to Retroactive.)

### **Via the SX Tool**

Bit X9 of PM Item **PMnOPT** defines the Sequencer Control mode as follows:

X9 = 0 Proactive Control

X9 = 1 Retroactive Control

## Configuring the Sets and Stages

This setting configures the number of stages in each set. For example, when the first set contains three stages, NST1 (Stg 1 first of ) is defined as 3, and NST2 (Stg 2 first of ) and NST3 (Stg 3 first of ) are defined as 0. A second set is then defined by NST4 (Stg 4 first of) with the required stages for that set, and the following Alg. Items NSTn in numerical sequence are defined as 0, and so on, until all required stages are defined. A binary code sequence will only operate on the first set as defined by NST1. In Version 1.1 or later; an option is available to reverse the action of all stages within sets, except the first stages. When this option is enabled, all stages within a set are switched on when the first stage of a set is switched on, and then the second and subsequent stages are switched off as the load increases. As the load decreases, stages are switched on again. A set cannot be switched off until all its stages are on. This option is applicable to chiller compressor control where the stages are connected to unloader solenoids.

### ***Via the GX Tool***

Select the sequencer module and then **Data** to call up the Data Window. At the **Stg #n first of** field, enter a value to determine the number of stages in the set. If there are no sets, enter 1 at each **Stg #n first of** field for the number of individual stages needed. At the **Invert Stgs in set** field on page 2, enter 1 to reverse the action of stages in sets.

For a binary sequencer module, select the binary sequencer module, and then **Data** to call up the Data Window. At the **Number of Stages** field, enter the number of outputs to be controlled as one binary coded set.

### ***Via the SX Tool***

Enter the appropriate values at Alg. Item **NSTn** (n = 1-8) (RI.02 to RI.09).

The reverse stages in sets option is defined in bit X6 of PM Item **PMnOPT** as follows:

|                             |  |
|-----------------------------|--|
| X6 =0 Direct Stages in Sets | All stages are switched On for increasing load.  |
| X6 =1 Invert Stages in Sets | Stages within a set are switched On when the set is On and switched Off for increasing load. |

## Configuring the Disable Conditions

This setting configures the disable condition connections for the sequencer. When a stage is disabled by its connection being equal to 1, the sequencer will immediately switch off the stage and automatically select the next available stage according to the Sequencer mode defined. When any stage of a set is disabled, the complete set is considered as disabled and all stages are immediately switched off, and the sequencer will automatically select the next available set. Therefore, only the first stage needs to be disabled in order to disable all stages within a set. A disabled condition in a Binary Code sequencer will disable the sequencer operation. If a stage (or set) is disabled, the sequencer will use the load factors assigned to the enabled stages to run the sequencer.

### *Via the GX Tool*

Make connections between the logic source points and the DISn@ disable points in the sequencer module. In the binary sequencer module make a connection between the logic source point and the DIS@ disable point.

### *Via the SX Tool*

To disable an output stage, enter the address of a logic variable at Alg. Item **DISn@** (n = 1-8) (RI.10 to RI.17).

## Configuring the Load Factors and Differential

The load factor of each stage is entered as a percentage of the maximum load required from all stages controlled by the sequencer module. The sum of the load factors of the stages may be greater than 100% if the controlled plant has standby capacity. For example, if a plant comprises five units where the maximum required load is provided by four units, and one unit acts as a standby, the load factor of each unit (stage) is set at 25%. If the units are not of equal capacity, the appropriate load factors (as a percentage of the maximum required load) may be entered and the algorithm will always switch the appropriate number of units available (i.e., those which are not disabled and have not exceeded their maximum switching cycles limit) to meet the required load.

The load differential must normally be less than the minimum load factor entered for any stage. If the load differential is greater than the load factor of the first stage in a set, that set may not switch off at 0% load in Retroactive Control mode, and more than one stage may remain on at 0% load in Proactive Control mode. This can be avoided in Step mode by setting the load factor of the first stage at a higher value than the load differential, because in Step mode the first stage is always the last to be switched off in the sequence. (In other modes, any stage or set could be the last to be switched off because the algorithm changes the order of operation.)

When the binary code option is selected, the algorithm will automatically assign load factors, which will summate to 100%, and the differential will be set to 20% of the minimum (first stage) load factor with a maximum of 3% of the total load.

#### ***Via the GX Tool***

Select the sequencer module and then **Data** to call up the Data Window. Go to page 2. At the **Ld Fctr Stg #n (%)** field, enter the percent for each stage that has been defined.

At the **Load Diffrential (%)** field, enter a value to determine the differential between successive on and off operations.

#### ***Via the SX Tool***

The output load factor is defined by Alg. Item **OLFn** (n = 1-8) (RI.26 to RI.33). The differential between successive on and off operations is set in Alg. Item **LDF** (RI.45).

### **Configuring the Timers**

A series of delay times have to be defined to control the sequencing steps. A set or stage cannot be switched until the delay time of the previous set or stage has expired.

Note: The sequencer module will only switch one set or stage during each program cycle, which occurs every second. Therefore, the minimum effective time delay between sets or stages is one second. Time values of less than one second will result in a delay time of one second.

#### ***Via the GX Tool***

Select the sequencer module and then **Data** to call up the Data Window. Go to page 2. Set the following values (in seconds):

First set on delay: Delay between the first and second stages of the first set, or delay between the first and second set if the first set has only one stage.

Stage on delay: Delay between stages, and delay between the last stage of one set and the first stage of the next set.

Set on delay: Delay between stage one and stage two of a set other than the first set, or delay between sets other than the first set if the sets have only one stage.

Stage off delay: Off delay between stages.



Set off delay: Off delay between the last stage to be switched off one set and the first stage to be switched off the next set, or off delay between sets if the sets only have one stage.

At the **Minimum On Time (sec)** field, enter a value . It defines the time in seconds that a stage must be On before it may be switched Off.

At the **Minimum Off Time (sec)** field, enter a value. It defines the time in seconds that a stage must be Off before it may be switched On.

If the Minimum On Time and Minimum Off Time are only applied to the first stages in each set, then at the **Min On/Off for set** field, enter a 1.

For a BIN SEQ, select **DATA** and set **Interstage Delay** (in seconds).

### ***Via the SX Tool***

Define the sequencing timing control as follows:

|    |                    |        |         |
|----|--------------------|--------|---------|
| T1 | First Set On Delay | [sec.] | (RI.34) |
| T2 | Stage On Delay     | [sec.] | (RI.35) |
| T3 | Set On Delay       | [sec.] | (RI.36) |
| T4 | Stage Off Delay    | [sec.] | (RI.37) |
| T5 | Set Off Delay      | [sec.] | (RI.38) |

The Minimum On Time for a stage or set is defined by Alg. Item **TON** (RI.41). It defines the time in seconds that a stage must be On before it may be switched Off.

The Minimum Off Time for a stage or set is defined by Alg. Item **TOFF** (RI.42). It defines the time in seconds that a stage must be Off before it may be switched On.

If bit X7 of PM Type **PMnOPT** (RI.01) is set to 1, the Items **TON** and **TOFF** will only be applied to the first stage in a set and not to the other stages in the same set (if any).

A Binary Code sequencer does not use the Minimum On and Off time parameter.

## Configuring Maximum Switching Cycles

The sequencer algorithm controls the starting of the first stage in each set such that the number of starts in one hour does not exceed the defined Maximum Switching Cycles value (MAXC). The algorithm does this by calculating the minimum time between start commands using the formula:  $3600 \text{ sec.}/\text{MAXC}$ . The first stage in a set is effectively locked out and prevented from restarting within this period of time. This time is typically longer than the Minimum Off Time.

When operating in Step or Sequential mode, the sequencer will wait for a set to become available again after a previous start command. In Equal Runtime mode, a set that is unavailable will be skipped and the set with the next lowest runtime will be selected.

In a Binary Code sequencer, the MAXC parameter is not used.

### *Via the GX Tool*

Select the sequencer module and then **Data** to call up the Data Window. At the **Max Switch Cycl/hr** field, enter a value for cycles per hour. For example, if equal to 6, a stage will only be allowed one start every ten minutes.

### *Via the SX Tool*

The maximum number of switching cycles allowed for the first stage of each set in one hour is defined by Alg. Item **MAXC** (RI.43).

## Configuring Fast Step Down

A digital input connection will initiate a Fast Step Down cycle of the sequencer. The Fast Step Down cycle is controlled by a Fast Step Down Stage Delay and a Fast Step Down Set Delay. The Fast Step Down cycle does not respect the Minimum On Time parameter. Once the procedure is activated, it cannot be interrupted until the switching-off sequence is completed and all stages are off. The Fast Step Down connection is also used to switch off the final proactive load in the sequence when the plant is shut down.

### *Via the GX Tool*

Make a connection between the Fast Step Down logic source point and the FST@ input in the sequencer or binary sequencer module. Select the module and then **Data** to call up the Data Window. Enter values (in seconds) for the following fields:

Fast Step Dwn (Stg): Off delay between stages.

Fast Step Dwn (Set): Off delay between the last stage to be switched off of one set and the first stage to be switched off of the next set, or off delay between sets if the sets only have one stage.

### ***Via the SX Tool***

A digital input connected to Alg. Item **FSD@** (RI.20) initiates the Fast Step Down cycle of the sequencer. The Fast Step Down cycle is controlled by the Fast Step Down Stage Delay **T4F** (RI.39) and the Fast Step Down Set Delay **T5F** (RI.40).

### **Notes**

1. You can view and override the sequencer output value and totalized runtime (in hours) of each stage using the DX front panel. See *Display Panel and Keypads* in the *DX-9100 Extended Digital Controller Technical Bulletin (LIT-6364020)* in *FAN 636.4* or *1628.4*.
2. The output status of each stage can be seen on the SX Tool at PM Item **PMnDO** (RI.71) bits X1 to X8.
3. The requested load can be seen on the SX Tool at Alg. Item **OUT** (RI.60).
4. The output difference of the algorithm can be seen on the SX Tool at Alg. Item **OUTD** (RI. 61). It represents the required load minus the sum of the loads of all stages that are On. It can be used to control a modulating device between the switching of stages to provide continuous control over the complete range (sometimes referred to as Vernier control).
5. The sum of the loads of all stages that are On can be seen on the SX Tool at Alg. Item **OUTS** (RI.62).
6. The runtime (in hours) of each stage can be seen on the SX Tool at Alg. Item **RTn** (n = 1-8) (RI.73 to RI.80).
7. The sequencer module can be put in Hold mode by entering the value 1 in Alg. Item **PMnHDC** (RI.70, bit X1). The requested output Alg. Item **OUT** can be modified in the Hold mode by a BAS.
8. The output disabled status (1 for Disabled) of each stage can be seen on the SX Tool at Alg. Item **PMnST** (RI.72, bits X1 to X8).
9. The status of the maximum switching cycles per hour timer for each stage can be seen at Alg. Item **PMnST** (RI.72, bits X9 to X16).
10. When a stage is switched on, the respective bit is set to 1 to indicate that it cannot be switched on again until its timer expires (if it is the first stage in a set).

11. A sequencer module may be chained to the next programmable function module (in numerical sequence) by setting bit X16 in the PM Item **PMnOPT** (RI.01) to 1. (For GX: Select the sequencer module and then **Data** to call up the Data Window. In the **Chain Next PM (0=N)** field, enter 0 for No, 1 for Yes.) When a sequencer module is chained, the next programmable function module must be defined as a sequencer module where Stages 1-8 will act as Stages 9-16 and use the same data for Items INC@, DEC@ and FSD@, T1 - T5, T4F and T5F, TON, TOF, MAXC, FLR, and LDF in the first module. Only NSTn, OLFn, and DISn@ are required in the second module and its outputs OUT, OUTD, and OUTS have no meaning. (In the GX Tool only: Stage# first of, Output Load Fctr, and Disable are required.)

## GX Labels

### Source Points (Outputs)

- PMnHLD** A 1 when the program module is in the Hold mode, being overridden by the SX Tool or a BAS.
- PMnMCSm** A 1 as long as the *maximum cycles status* timer for an output stage is active.
- PMnOUT** The analog value of the requested *output* load % (percent) of a sequencer.
- PMnOUTD** The *output difference* between the required load minus the sum of the loads of stages that are On in a Sequencer mode. This can be used for Vernier control.
- PMnSTOm** A 1 when the *staged output* of a sequencer module is requested to be On.

### Destination Points (Inputs)

- DEC@** The connection to decrement an analog type output, PAT/DAT digital type output or a sequencer module. While connection is a logic 1, the output will *decrease* at a rate dependent on the type of module.
- DISn@** A connection in a sequencer to *disable* the corresponding stage or set number.
- FST@** The connection to set the sequencer module into *Fast Step Down* mode.
- INC@** The connection to increment an analog type output, PAT/DAT digital type output or a sequencer module. While connection is a logic 1, the output will *increase* at a rate dependent on the type of module.

## Configuration Examples

The following examples show a sequencer with eight stages, subdivided into one set of two stages and two sets of three stages:

### ***Via the GX Tool***

|                      |                      |
|----------------------|----------------------|
| Stage 1 first of = 2 | Stage 5 first of = 0 |
| Stage 2 first of = 0 | Stage 6 first of = 3 |
| Stage 3 first of = 3 | Stage 7 first of = 0 |
| Stage 4 first of = 0 | Stage 8 first of = 0 |

The sequencer is defined by connecting an analog source point to **INC@**. Proactive control is defined by entering 0 under the **Retroactive (0=N)** field on page 2.

The output load factors are defined (in percentages) as follows:

|                        |                        |
|------------------------|------------------------|
| Ld Fctr Stg 1 (%) = 10 | Ld Fctr Stg 5 (%) = 10 |
| Ld Fctr Stg 2 (%) = 10 | Ld Fctr Stg 6 (%) = 20 |
| Ld Fctr Stg 3 (%) = 10 | Ld Fctr Stg 7 (%) = 20 |
| Ld Fctr Stg 4 (%) = 10 | Ld Fctr Stg 8 (%) = 10 |

The Load Differential is set to 2% via **Load Diffrential (%) = 2** field.

### ***Via the SX Tool***

Alg. Items **NSTn** (RI.02 to RI.09) must be defined as follows:

|          |          |
|----------|----------|
| NST1 = 2 | NST5 = 0 |
| NST2 = 0 | NST6 = 3 |
| NST3 = 3 | NST7 = 0 |
| NST4 = 0 | NST8 = 0 |

The sequencer is defined with an analog input connected to **INC@** (X8 = 0), and Stage 1 is On at 0% load (proactive control X9=0).

The output load factors **OFL** 1 to 8 (RI.26 to RI.33) are defined as follows:

|           |           |
|-----------|-----------|
| OLF1 = 10 | OLF5 = 10 |
| OLF2 = 10 | OLF6 = 20 |
| OLF3 = 10 | OLF7 = 20 |
| OLF4 = 10 | OLF8 = 10 |

The differential **LDF** (RI.45) is defined as 2%.

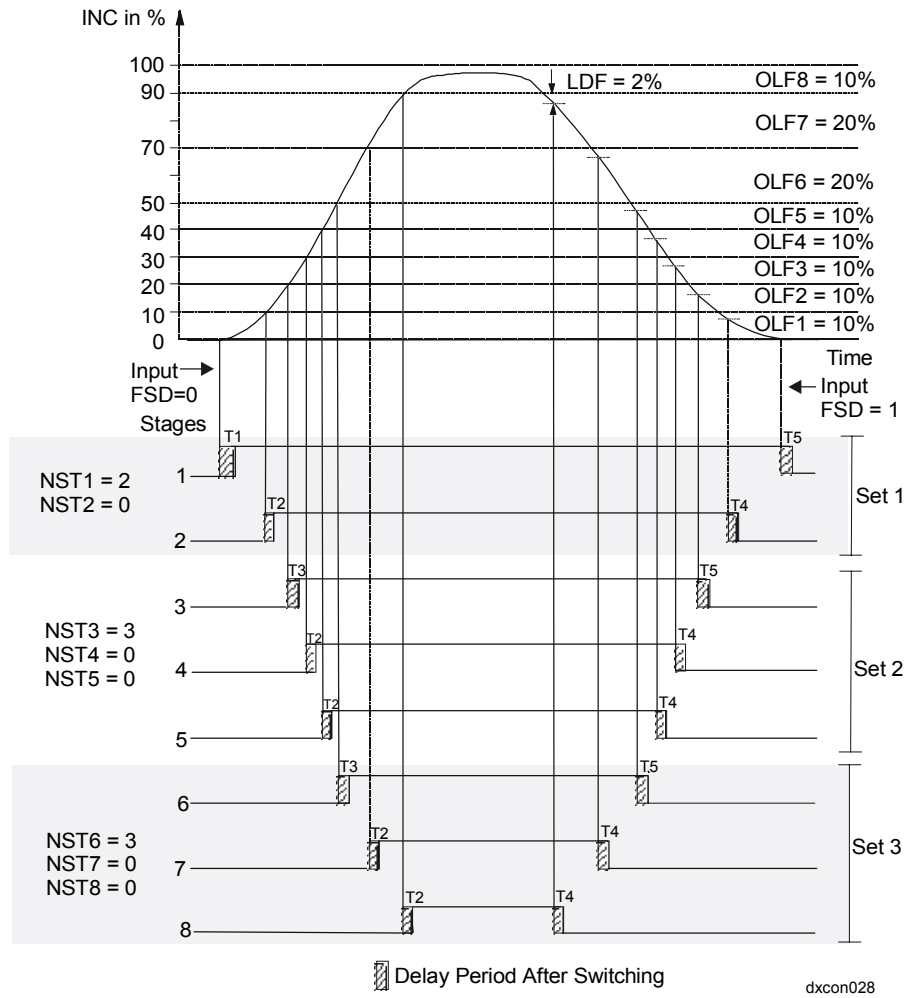

**Figure 26: Sequencer Module Example 1, Step Mode**

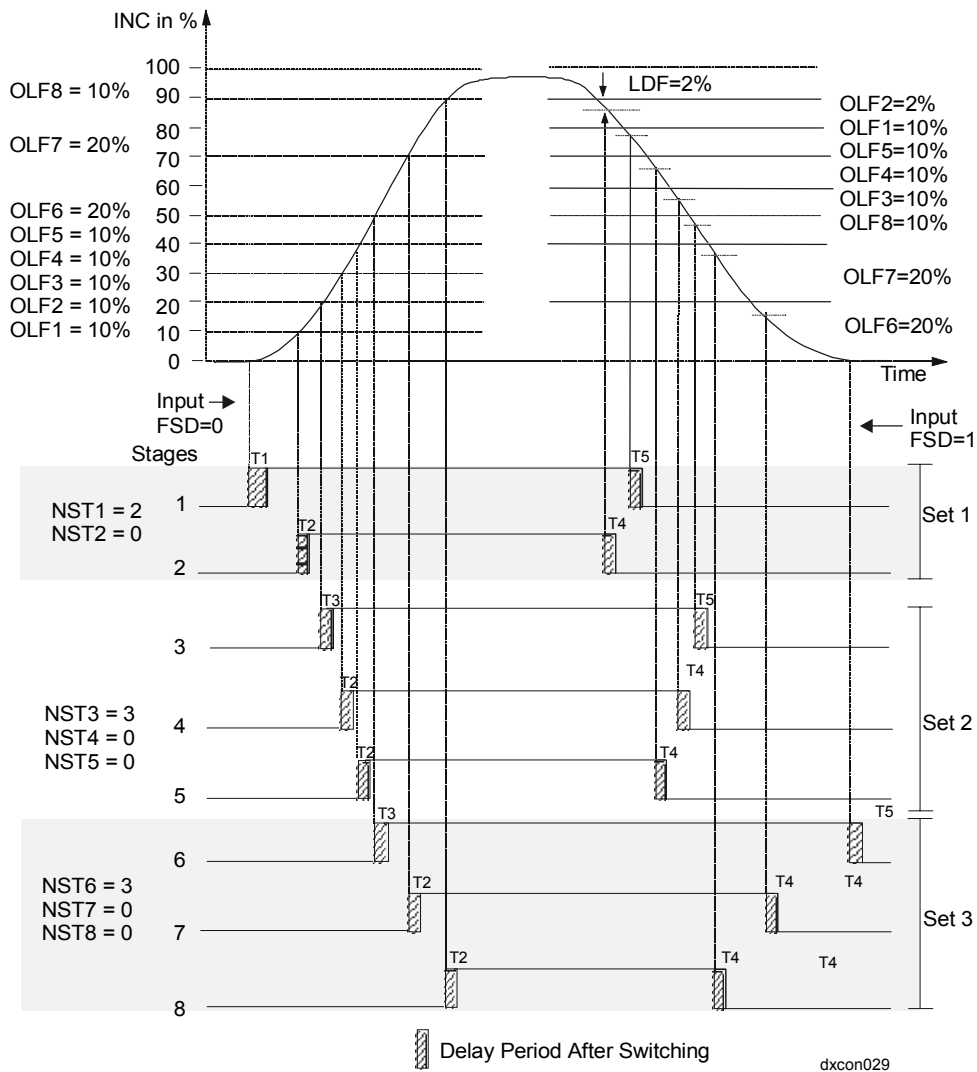
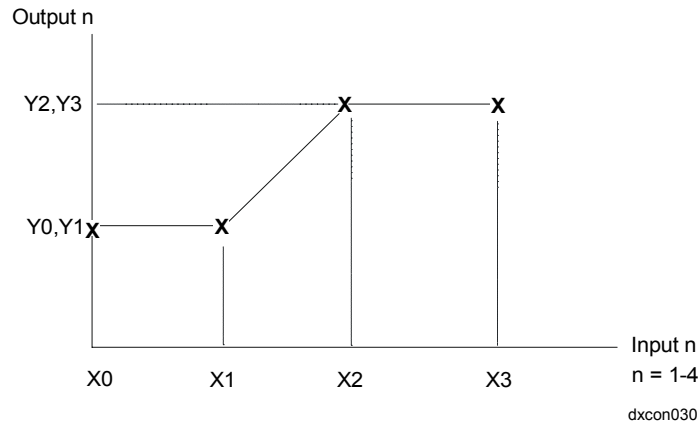

**Figure 27: Sequencer Module Example 2, Sequential Mode**

---

**Algorithm 23 –  
Four Channel  
Line Segment  
(Version 1.1 or  
Later)**

Each channel of a four channel line segment has an output, which is a nonlinear function of its input variable defined on an X,Y plane using four break points. The function is linear between break points. The input break values must go in increasing order, although the output break values can increase or decrease. This is typically used for a simple reset schedule.



**Figure 28: Example of a Line Segment Function**

**Function**

***Via the GX Tool***

Click on **PM** in the toolbar, select **Numeric**, then **Four-Segment**, and position the module (box) on the screen. Make connections between the numeric source points and In@ inputs, as applicable.

Select the module and then **Data** to call up the Data Window.

Under **CH #n**, in the **X** column, enter input (X) break values at the 0, 1, 2, and 3 fields. In the **Y** column, in each field, enter the output (Y) break value, which corresponds to the input entry. Define the values of X for the complete range of the input.



### **Via the SX Tool**

This algorithm is assigned to a programmable function module when the value 23 is configured in PM Item **PMnTYP** (RI.00).

For Channel n (n = 1-4):

In@ = Input Variable Connection (RI.10 to RI.13)

Break Point 0 defined by coordinates X0-n,Y0-n  
(X0-n; RI.26, .34, .42, .50; Y0-n; RI.27, .35, .43, .51)

Break Point 1 defined by coordinates X1-n,Y1-n  
(X1-n; RI.28, .36, .44, .52; Y1-n; RI.29, .37, .45, .53)

Break Point 2 defined by coordinates X2-n,Y2-n  
(X2-n; RI.30, .38, .46, .54; Y2-n; RI.31, .39, .47, .55)

Break Point 3 defined by coordinates X3-n,Y3-n  
(X3-n; RI.32, .40, .48, .56; Y3-n; RI.33, .41, .49, .57)

### **Notes**

1. The output of each channel can be seen on the SX Tool at Alg. Item **NCMn** (RI.60 to RI.63).
2. X values *must* be entered in ascending order and the same number may *not* be entered twice. Unlike Algorithm 16, the outputs for inputs outside of the defined range are as follows:  
for  $X < X_0$ ,  $Y=Y_0$   
for  $X > X_3$ ,  $Y=Y_3$
3. Each channel of the module can be put in Hold mode by entering the value 1 in Alg. Item **PMnHDC** (RI.70 bits X1 to X4) on the SX Tool or by the PLC. The channel output may be modified by a BAS when in Hold mode.
4. As the numeric output cannot be read at the DX front panel, it is recommended that this algorithm is used in the higher PM numbers, reserving the lower PM numbers for algorithms that can be displayed.

### **GX Labels**

#### **Source Points (Outputs)**

**PMnHLDm** A 1 when the channel of the program module has been overridden (in hold) from an SX service module or a BAS.

**PMnNCMm** The calculation result of a channel of a *numeric module*.

#### **Destination Points (Inputs)**

**In@** *Analog input* connections to a programmable module.

---

**Algorithm 24 –  
Eight Channel  
Calculator  
(Version 1.1 or  
Later)**

Each channel of an eight channel calculator has an output that is the result of an algebraic expression of two input variables. When an input is not connected, a value of 1 is assumed and the corresponding constant (Kn) must be set to the required value. If the denominator is 0, the equation outputs the last reliable calculation.

The following show how the calculations are actually performed:

$$(K1-n * I1-n) + (K2-n * I2-n)$$

$$(K1-n * I1-n) - (K2-n * I2-n)$$

$$(K1-n * I1-n) * (K2-n * I2-n)$$

$$(K1-n * I1-n) / (K2-n * I2-n)$$

$$\text{MIN} (K1-n * I1-n, K2-n * I2-n)$$

$$\text{MAX} (K1-n * I1-n, K2-n * I2-n)$$

**Function**

**Via the GX Tool**

Click on **PM** in the toolbar, select **Numeric**, then **Eight-Calculator**, and position the module (box) on the screen. Select the module and then **Data** to call up the Data Window. At the **Ch #n Equation Type** field, enter the value to describe the equation type:

- 0 = Disabled
- 1 = Addition
- 2 = Subtraction
- 3 = Multiplication
- 4 = Division
- 5 = Minimum Select
- 6 = Maximum Select

Then enter the constant values for the different channels by selecting the **Constant K1**, **Constant K2**, etc., fields and entering values for the desired calculation.

Make connections between numeric source points and module inputs I1-n@ and I2-n@.

### **Via the SX Tool**

This algorithm is assigned to a programmable function module when the value 24 is configured in PM Item **PMnTYP** (RI.00). The bit structure of the Alg. Item **FUNn** (RI.02 to RI.09) defines the function of the algorithm channel where n = 1-8.

|              |                |
|--------------|----------------|
| X3X2X1 = 000 | Disabled       |
| X3X2X1 = 001 | Addition       |
| X3X2X1 = 010 | Subtraction    |
| X3X2X1 = 011 | Multiplication |
| X3X2X1 = 100 | Division       |
| X3X2X1 = 101 | Minimum        |
| X3X2X1 = 110 | Maximum        |

I1-n@ = Input Variable 1 Channel n. (even numbers RI.10 to RI.24)

I2-n@ = Input Variable 2 Channel n. (odd numbers RI.11 to RI.25)

K1-n = Constant 1 Channel n (even numbers RI.26 to RI.40)

K2-n = Constant 2 Channel n. (odd numbers RI.27to RI.41)

### **Notes**

1. The output of each channel can be seen on the SX Tool at Alg. Item **NCMn** (RI.60 to RI.67).
2. Each channel of the module can be put in Hold mode by entering the value 1 in Alg. Item **PMnHDC** (RI.70, bits X1 to X8) on the SX Tool or by the PLC. The channel output may be modified in the Hold mode by a BAS.
3. As the numeric output cannot be read at the DX front panel, it is recommended that this algorithm is used in the higher PM numbers, reserving the lower PM numbers for algorithms, which can be displayed.
4. To build up more complex equations the output of one channel may be connected to the input of another channel to form a chain. Note that outputs only get transferred to inputs when the module begins execution so that there is always a delay of one second between individual channel calculations in one module when they are chained.

### **GX Labels**

#### **Source Points (Outputs)**

**PMnHLDm** A 1 when the channel of the program module has been overridden (in hold) from an SX service module or a BAS.

**PMnNCMm** The calculation result of a channel of a *numeric module*.

#### **Destination Points (Inputs)**

**In-m@** Analog input connections to an eight channel calculator module.

---

## **Time Program Functions**

### **Real Time Clock**

The following variables are available and may be displayed on the front panel of the controller:

|                |  |   |
|----------------|--|---|
| Year:          | Years  | 1990-2020<br>(up to 2035 in Versions 1.4, 2.3, and 3.3, or later) |
| Month:         | Month of the year  | 1-12  |
| Day:           | Day of the month   | 1-31  |
| Hour:          | Hours since midnight   | 0-23  |
| Minute:        | Minutes after the hour   | 0-59  |
| Day Of Week:   | 1=MONDAY<br>2=TUESDAY<br>3=WEDNESDAY<br>4=THURSDAY<br>5=FRIDAY<br>6=SATURDAY<br>7=SUNDAY |   |
| Exception Day: | 8=HOLIDAY  |   |

The actual day of the week is automatically calculated as a function of the programmed calendar day at the power up initialization and at every date change.

### **Daylight Saving**

This function automatically advances the current time by one hour at the beginning of the daylight saving period and sets the current time back by one hour at the end of the period.

The daylight saving period begins at time 00:00 of the START DATE and ends at 01:00 of the END DATE.

#### ***Via the GX Tool***

To set daylight saving dates, select **Edit-Global Data**. At the **DL Savings Start Date (MM/DD)** field, enter the date of the Sunday when the next daylight saving period begins. At the **DL Savings End Date (MM/DD)** field, enter the date of the Sunday when the current or next daylight saving period ends.

(This function cannot be accessed by the SX Tool, but can be executed from the front panel of the DX controller.)

## Exception Days

An exception day table, composed of up to 30 entries, determines exceptions for the day of the week status. On exception days, holiday status will be set and the day number will be set to 8.

Each entry in the table is described by a START DATE and an END DATE in the format [Month] [Day].

When the DX is at Day 8, the only schedules that will operate are ones that have been programmed with an 8 in the Days for Event.

*Examples:*

For a holiday of December 24 and 25, enter 12:24 as Start and 12:25 as End. For a holiday of January 1, enter 01:01 as Start and 01:01 as End.

### **Via the GX Tool**

Click on **PM** in the toolbar, select **Exception Days**, and position the module (box) on the screen. Select the module and then **Data** to call up the Data Window. At the **#n Start:** field, enter the date to start the holiday. At the **#n End:** field, enter the date to stop the holiday. For a single day holiday, enter the same date for start and end.

(This function cannot be accessed by the SX Tool, but can be executed from the front panel of the DX-9100 Controller.)

---

## **Time Schedule Configuration**

The eight time schedule modules each provide the control of a logic output as a function of a programmable event schedule, the day of the week, exception days condition, and of the realtime clock.

One time schedule can contain up to eight entries, each containing the following information:

- **START TIME:** [Hour][Minute]
- **STOP TIME:** [Hour][Minute]
- **DAYS FOR EVENT:** To select on which days of the week (Mon, Tue, Wed, Thu, Fri, Sat, Sun, and Holiday) the START/STOP command will be issued; the command may be enabled for more than one day.

The event on time can be extended to cover a period greater than one day by programming the STOP TIME of one event as 24:00 and the START TIME of the next event as 00:00. If, for one event, the STOP TIME is earlier than the START TIME, the DX (when downloaded) will automatically change the STOP TIME to one minute after the START TIME.

The time schedule module is executed each minute. If external forcing conditions are not present, the event schedule is examined to verify whether a start/stop command is programmed for the actual time and day of the week.

## **GX Tool**

### ***Via the GX Tool***

Click on **PM** in the toolbar, select **Time Schedule**, and position the module (box) on the screen. Select the module and then **Data** to call up the Data Window. Set the start and stop times in the respective fields:

Start Time Event #n

Stop Time Event #n

Then, at the **Days for Event #n** field, enter a value corresponding to the desired schedule:

1=MONDAY

2=TUESDAY

3=WEDNESDAY

4=THURSDAY

5=FRIDAY

6=SATURDAY

7=SUNDAY

8=HOLIDAY (Exception Day)

0=ALL DAYS (Monday to Sunday - Not Holiday)

9=WEEKDAYS (Monday to Friday)

Example: For days Monday, Tuesday, and Wednesday, enter 123.

## **Output Type**

### ***Via the SX Tool***

Bit X1 of Item **TSnOPT** (RI.00) defines the output type. It should be set to 0 for logic output type, which is the only available output type in the current versions of firmware. (This setting is available only through the SX Tool.)

## **Overriding the Time Schedule**

Three logic inputs can override the normal function of the time schedule module:

- The External Extension Connection defines a logic variable which, if On at a programmed stop time of the module, extends the On period for a programmed extension time. (The extension can also be set from the DX front panel or by a BAS when the module output is On. See the following *Notes* section.)

- The On Forcing Connection forces the output to On, if the connection equals 1.
- The Off Forcing Connection forces the output to Off if the connection equals 1.
- The logic forcing inputs are executed according to following priority: forcing to Off, forcing to On, and extension.

### ***Via the GX Tool***

Select the time schedule module and then **Data** to call up the Data Window.

Make connections between External Forcing On source points and TSnON@ inputs. Similar connections for Off Forcing TSnOF@ and for Extension External TSnEX@ can be made as required.

At the **Extension Time** field, enter a value for the desired extension time in minutes (0 - 255).

### ***Via the SX Tool***

Set the connections via the following Items:

- The External Extension Connection Item = **TSnEX@** (RI.01).
- The On Forcing Connection Item = **TSnON@** (RI.02).
- The Off Forcing Connection Item = **TSnOF@** (RI.03).

The value in Item **TSnXTM**, (RI.04) defines the extension time (0-255minutes).

## **Notes**

1. The time, date, year, extension time, daylight saving dates, time schedule output, and start/stop event days and times can be read and modified using the DX front panel. See *Display Panel and Keypads* in the *DX-9100 Extended Digital Controller Technical Bulletin (LIT-6364020)* in *FAN 636.4* or *1628.4*.
2. The extension can be set from the DX front panel. See *Display Panel and Keypads* in the *DX-9100 Extended Digital Controller Technical Bulletin* in *FAN 636.4* or *1628.4*.
3. On the SX Tool, the value in Item **TSnTIM** (RI.05) indicates the time in minutes to the next change of the logic output TSnOUT. This output will be active when a change of output within the current or next day is scheduled.

4. The bit values in Item **TSnSTA** (RI.06) indicate on the SX Tool the time schedule status as follows:
 

|      |         |   |
|------|---------|---|
| X1=1 | TSnHLD  | Time schedule module is in Hold mode. The output of the module (TSnOUT) can be modified in the Hold mode.   |
| X2   | TSnOUT  | Output status and control is the output of the time schedule module, and can be used as logic input to any of the programmable or output modules.           |
| X3=1 | TSn EXT | Extension command is set by an extension ?? override command from the DX front panel or BAS. This command toggles the extension status (TSnEXS) on and off. |
| X4   | TSnNXO  | Indicates the next scheduled output of the time schedule module (0 or 1).   |
| X5=  | 1TSnEXS | Indicates an active extension from the DX front panel or BAS.   |
| X6=1 | TSnXDI  | Indicates an active extension from a logical (digital) input (via the External Extension Connection).   |
| X7=1 | TSnON   | Indicates a forced On status.   |
| X8=1 | TSnOFF  | Indicates a forced Off status.  |

Status Items can be used as logic (digital) connections using the GX Tool or SX Tool.
5. When an extension is set from the DX front panel or by a BAS, the extension status (TSnEXS) of the module is true (bit X5 = 1). An extension via the DX front panel or BAS is automatically reset when the extension period ends.
6. When an extension is set by the External Extension Connection, the extension status TSnXDI of the module is true (Bit X6 = 1) when the output status (TSnOUT) is true, and remains true until the end of the extension period.
7. When making a connection from a time schedule module to an optimal start/stop module, the Items TSnOUT, TSnNXO, and TSnTIM must be connected via the SX Tool. If using the GX Tool, when TSnOUT is connected, the TSnNXO and TSnTIM are connected internally.
8. When a start or stop time of an event in a time schedule module is changed, the time schedule module will take up to one minute to update its output.
9. Time schedules may be uploaded, modified, and downloaded at the Operator Workstation (OWS). Refer to the *Scheduling Technical Bulletin (LIT-636116)* in *FAN 636*.



## GX Labels

### Source Points (Outputs)

- TSnEXS** A 1 when a *time schedule* module has its *extension* enabled by a BAS or a DX front panel command.
- TSnOUT** A 1 when the real time is currently between the start and stop times of an event of the *time schedule* module and the current day is specified for that event.

### Destination Points

- TSnOF@** A connection to externally force the output of a *time schedule* to Off.
- TSnON@** A connection to externally force the output of a *time schedule* to On.
- TSnEX@** A connection to the external extension of a *time schedule*.

---

## Optimal Start/Stop Configuration

Two optimal start/stop modules each calculate the minimum time needed to bring a controlled zone temperature to a desired condition at occupancy time under heating and/or cooling conditions. The modules also calculate the optimal stop time to maintain the desired conditions up to the end of the occupancy time.

When an optimal start/stop module is configured for heating and cooling, the module assumes a:

- Heating mode for startup if the zone temperature is below setpoint
- Cooling mode for startup if the zone temperature is above setpoint
- Heating mode for shutdown if the outdoor temperature is below the zone on setpoint
- Cooling mode if the outdoor temperature is above the zone on setpoint

## Function

### Via the GX Tool

Click on **PM** in the toolbar, select **Optimum Start/Stop**, and position the module (box) on the screen. Select the module and then **Data** to call up the Data Window. At the **Module Type** field, enter the value corresponding to the desired configuration:

- 1 = Heating
- 2 = Cooling
- 3 = Heating and Cooling

### Via the SX Tool

The **OSnOPT** (RI.00) defines the operating mode of the optimal start/stop module by setting bit X1 and X2 as follows:

- X2X1 = 00 Not used
- X2X1 = 01 Heating mode (heating plant only)
- X2X1 = 10 Cooling mode (cooling plant only)
- X2X1 = 11 Heating and Cooling mode (plant heats and cools)

The status of the mode can be seen at Item **OSnSTA**, bit X3, (OSn HEAT) where 0 = Cooling and 1 = Heating.

### Optimal Start Adaptive Process

The adaptive process monitors how quickly the temperature reaches the halfway point between the setpoint and actual temperature:

- If it takes less than the calculated warmup time based on the building factor, then the building factor will be decreased so that the next calculation will result in a shorter warmup time, all other factors being equal.
- If it takes more than the calculated warmup time based on the building factor, then the building factor will be increased so that the next calculation will result in a longer warmup time, all other factors being equal.

The adaptive process calculation only takes place when the Optimal Start module actually starts the plant.

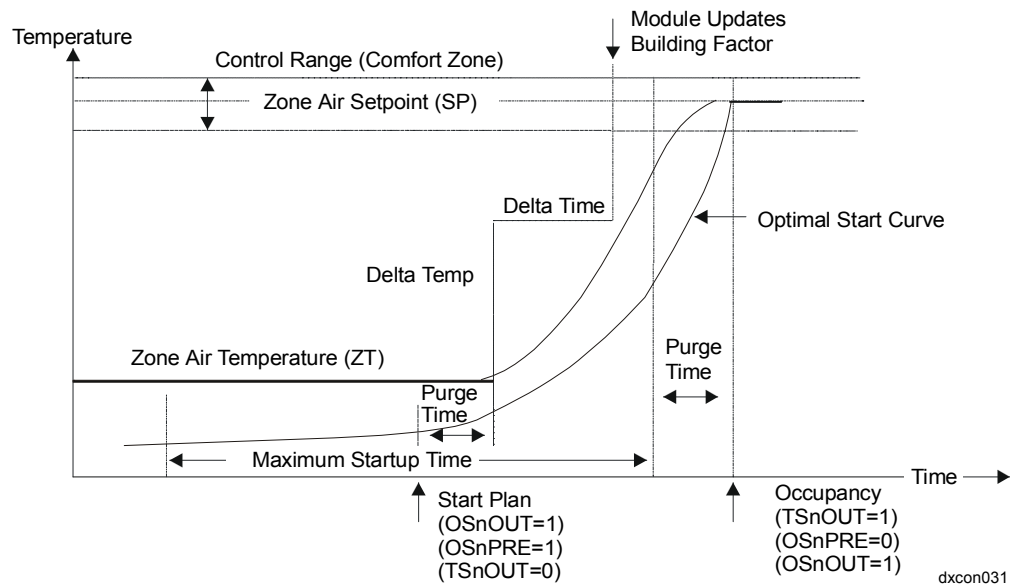

**Figure 29: Optimal Start Module in Heating Mode**

The required startup time is calculated as follows:

$$\text{WarmupTime} = \text{BuildingFactor}(\text{Heating}) \times (\text{SP} - \text{ZT} + \text{TC})^2 + \text{PT}$$

$$\text{TC} = \frac{(\text{HTD} - \text{OT})}{4} \text{ when } \text{HTD} > \text{OT}, \text{ else } \text{TC} = 0$$

$$\text{Cooldown Time} = \text{Building Factor}(\text{Cooling}) \times (\text{ZT} - \text{SP} + \text{TC})^2 + \text{PT}$$

$$\text{TC} = \frac{\text{OT} - \text{CTD}}{4} \text{ when } \text{OT} > \text{CTD}, \text{ else } \text{TC} = 0$$

When the Zone Air Temperature has risen (when in heating mode) or fallen (when in cooling mode) halfway towards the Zone Setpoint, the module updates the corresponding Building Factor value using the following calculation:

$$\text{NBF} = \frac{(100 - \text{FW}) \times \text{OBF} + \text{FW} \times \text{deltaTime} / (\text{deltaTemp})^2}{100}$$

If the Zone Air Temperature does not reach the halfway point, the corresponding Building Factor is automatically increased by a fixed amount equal to 10% of the existing value.

The Building Factor is not updated if the initial Zone Air Temperature is within the Control Range.

- NBF = New Building Factor
- FW = Filter Weight
- OBF = Old Building Factor
- SP = Zone Air Setpoint Temperature
- ZT = Zone Air Temperature
- PT = Min. Heat/Cool Time (Purge Time)
- HTD = Outdoor Design Temperature Heating
- CTD = Outdoor Design Temperature Cooling
- TC = Temperature Compensation
- OT = Outdoor Temperature

The Building Factor (Heating) is updated in the Heating mode and the Building Factor (Cooling) is updated in the Cooling mode.

**Optimal Stop Operation**

If the difference between the outdoor air and the zone temperature is small, the heating equipment can be stopped at an earlier time than if the difference is large.

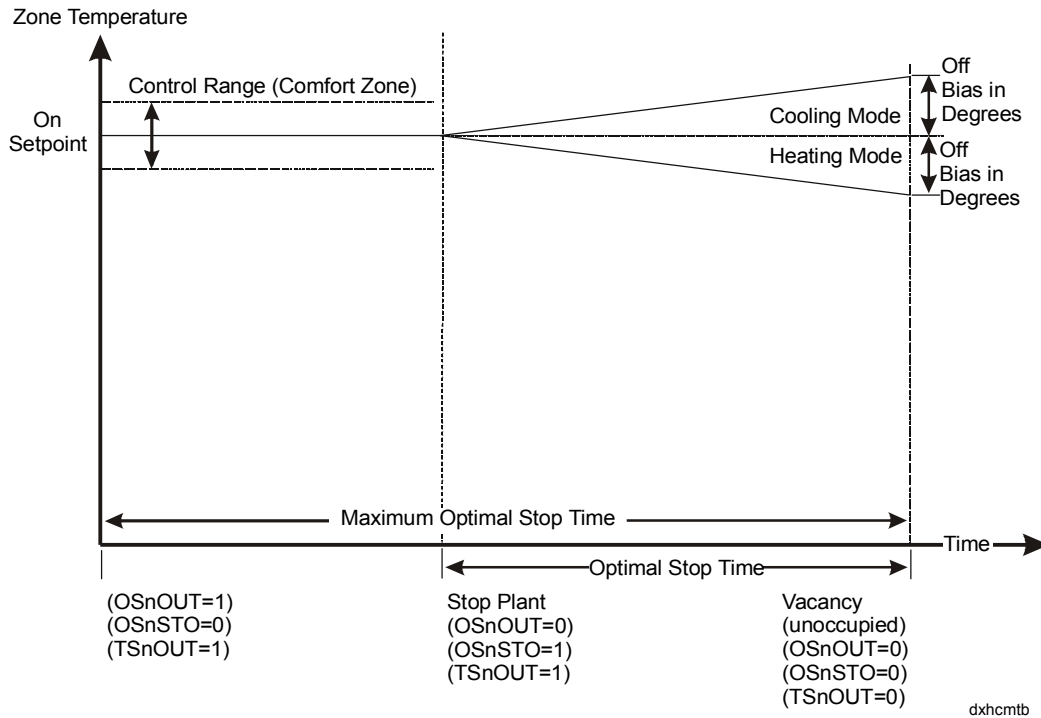

**Figure 30: Optimal Stop Module in Heating/Cooling Mode**

$$\text{Opt. Stop Time} = \frac{\text{Zone Temp. Off Bias} * \text{Shutdown Building Htg/Clg Factor}}{\text{Zone Temp.} - \text{Outdoor Temp.}}$$

or = Maximum Optimal Stop Time  
(whichever is least).

If the Zone Temperature (ZT) is not within the Control Range (CRNG), or Outdoor Temperature (OT) is not connected, the Optimal Stop algorithm is not executed and the output **OSnOUT** is reset at the normal vacancy time (i.e., the Optimal Stop Time set at 0).

**Zone Temperature**

The Zone Temperature is an analog input to the module, which gives the actual temperature of the conditioned zone.

**Via the GX Tool**

Make a connection between the Zone Temperature source point and the OSZT@ input point of the OSn module.

***Via the SX Tool***

Configure this function by entering the source address at Item **OSnZT@** (RI.01).

**Outdoor  
Temperature**

The Outdoor Temperature is an analog input to the module, which gives the actual outdoor temperature. If the input is not connected, the module does not compensate for outdoor temperature and the optimal stop function is disabled.

***Via the GX Tool***

Make a connection between the Outdoor Temperature source point and the OSOT@ input point of the OSn module.

***Via the SX Tool***

Configure this function by entering the source address at Item **OSnOT@** (RI.02).

**Zone  
Temperature  
on Setpoint**

This is the desired zone temperature at the scheduled occupancy time. If the connection is made, it will be the active setpoint. If there is no connection, the value entered as the Zone Temperature setpoint will be used.

***Via the GX Tool***

Make a connection between the Zone Temperature On setpoint source point and the OSSP@ input point of the OSn module. If connected, the value will replace the value entered at Zone Temp. SP.

Or, for a fixed setpoint, select the OSn module and then **Data** to call up the Data Window. At the **Zone Temp. SP** field, enter the desired zone temperature at occupancy.

***Via the SX Tool***

Configure the active setpoint by entering the source address at Item Location **OSnSP@** (RI.03). If no connection is made, the value entered at Item **OSnSP** (RI.21) will be used.

**Zone  
Temperature  
Off Bias**

This is an analog input or value that determines the maximum change in zone temperature during the optimal stop period. If the input is not connected, the module will use the value entered as the *Zone Temp. Off Bias*. For a heating plant only, the value must be negative; for a cooling plant only, the value must be positive. For the Heating and Cooling mode, an absolute value is used, and the Heating or Cooling mode is automatically determined by the module from the outdoor temperature. (Refer to Figure 30.)

***Via the GX Tool***

Make a connection between the Off Bias source point and the *OSOB@* input point of the OSn module. If there is no connection, the module will use the fixed value entered at the **Zn Tmp Off SP Bias** field. Or for a fixed bias, select the OSn module and then **Data** to call up the Data Window. Select the **Zn Tmp Off SP Bias** field, and enter the maximum change in zone temperature during the optimal stop period.

***Via the SX Tool***

The software connection is configured by entering the source address at the **OSnOB@** Item location (RI.04). If no connection is made, the value entered at Item **OSnOB** (RI.22) will be used.

**Disable Module**

This connection is a logic input, which disables the operation of the module. If the input is not connected, the module will use the default value 0 and the module will be enabled. When disabled, the Optimal Start module will simply output the start and stop commands of the Time Schedule module to which it is connected.

***Via the GX Tool***

Make a connection between the disable module source point and the *OSD1@* input point of the OSn module.

***Via the SX Tool***

Enter the logic source address at Item **OSnDI@** (RI.05).

**Disable Adaptive  
Action**

This connection is a logic input, which disables the adaptive operation of the module. If the input is not connected, the module will use the default value 0, and the module will be adaptive. The adaptation should only be disabled after the module has obtained some history and the configuration has been uploaded for safe keeping.

### ***Via the GX Tool***

Make a connection between the Disable Adaptive Action source point and the OSDA@ input point of the OSn module.

### ***Via the SX Tool***

Enter the logic source address under **OPT. ST.** at Item **OSnDA@** (RI.06).

## **Time Schedule Command Source**

The connection at OSnTS@ is a logic input that indicates the occupancy period of the zone controlled by the module. The source is a **TSnOUT** variable from a time schedule module. The optimal start module uses the time information from the time schedule module to determine the normal occupancy time and to calculate earlier start and stop times.

### ***Via the GX Tool***

Only TSnOUT logic variables may be selected.

Note: The Next Output and Time to Next Output mentioned below will automatically be connected by the GX Tool.

Make a connection between the TSnOUT source point and the OSTS@ input point of the OSn module.

### ***Via the SX Tool***

Enter the logic source address under **OPT. ST.** at Item **OSnTS@** (RI.07).

### ***Next Output (SX only)***

The connection at **OSnNX@** (RI.08) is a logic input that indicates the status of the next Start/Stop Command. The software connection is configured by entering the source address at the OSnNX@ Item location. The source is normally the **TSnNXO** variable from the time schedule module connected to the **OSnTS@** (RI.07) Item.

### ***Time to Next Output (SX only)***

The connection at **OSnTIM@** (RI.09) is a numerical input that indicates the time in minutes to the next output. The source is normally the TSnTIM variable from the time schedule module connected to the OSnTS@ Item (RI.07). The software connection is configured by entering the source address at the OSnTIM@ Item (RI.09) location.

## **Minimum Heat/Cool Time**

This parameter is a number, which defines the minimum time the AHU or other equipment should begin operating before occupancy (minutes) to condition the space to comfort setpoint.

***Via the GX Tool***

Select the OSn module and then **Data** to call up the Data Window. Select the **Min Startup Time** field, and enter a value in minutes.

***Via the SX Tool***

Enter a value under **OPT. ST.** at Item **OSnPURGE (RI.10)** in minutes.

**Maximum  
Startup Time**

This parameter is a number, which defines the time period (minutes) given for the module to calculate when to start the heating or air conditioning equipment before occupancy. The module begins its calculation when the maximum startup time is equal to the occupancy time minus the current time. This parameter is used to limit the startup time, and consequently the energy used; if its value is too small the space may not reach comfort setpoint by occupancy time under extreme weather conditions.

***Via the GX Tool***

Select the OSn module and then **Data** to call up the Data Window. Select the **Max Startup Time** field, and enter a value in minutes.

***Via the SX Tool***

Enter a value under **OPT. ST.** at Item **OSnMAXST (RI.11)** in minutes.

**Maximum  
Shutdown Time**

This is a number, which defines the time period (minutes) given for the module to calculate when to stop heating or air conditioning equipment before the end of occupancy. The module begins its calculation when the maximum shutdown time is equal to the normal vacancy time minus the current time.

***Via the GX Tool***

Select the OSn module and then **Data** to call up the Data Window. Select the **Max Shutdown Time** field, and enter a value in minutes.

***Via the SX Tool***

Enter a value under **OPT. ST.** at Item **OSnMAXSO (RI.12)** in minutes.

**Start Mode  
Building Factor  
(Heating)**

This factor is a number, expressed in min./degrees<sup>2</sup>, which defines the initial building factor for the first Optimal Start heating calculation. It will be automatically updated by the module when adapting is enabled. (For an understanding of the effect of different values, refer to the calculations under *Optimal Start/Stop Configuration*.)



### ***Via the GX Tool***

Select the OSn module and then **Data** to call up the Data Window. Select the **Start Heat. Factor** field, and enter an appropriate value or accept the default.

After a few weeks of operation, upload the configuration with the new value for record purposes and stop the adaptive process. (During seasonal transitions, the adaptive process may take longer to stabilize.)

Note: A new download to the controller will override any adaptively changed values with the values stored in the download file.

### ***Via the SX Tool***

Enter a value under **OPT. ST.** at Item **OSnBHK** (RI.13).

## **Start Mode Building Factor (Cooling)**

This factor is a number, expressed in min/degrees<sup>2</sup>, which defines the initial building factor for the first Optimal Start cooling calculation. It will be automatically updated by the module when adapting is enabled. (For an understanding of the effect of different values, refer to the calculations under *Optimal Start/Stop Configuration*.)

### ***Via the GX Tool***

Select the OSn module and then **Data** to call up the Data Window. Select the **Start Cool. Factor** field, and enter an appropriate value or accept the default.

After a few weeks of operation, note the new value for record purposes and stop the adaptive process. (Seasonal transitions may take longer to stabilize.)

Note: A new download to the controller will override any adaptive values with the values stored in the download file.

### ***Via the SX Tool***

Enter a value under **OPT. ST.** at Item **OSnBCK** (RI.14).

## **Stop Mode Building Factor (Heating)**

This factor is a number, expressed in min/degrees, which defines the building factor for the Optimal Stop heating calculation.

### ***Via the GX Tool***

Select the OSn module and then **Data** to call up the Data Window. Select the **Stop Heat Factor** field, and enter an appropriate value or accept the default.

### ***Via the SX Tool***

Enter a value under **OPT. ST.** at Item **OSnSBHK** (RI.15).

**Stop Mode  
Building Factor  
(Cooling)**

This factor is a number, expressed in min/degrees, which defines the building factor for the Optimal Stop cooling calculation.

***Via the GX Tool***

Select the OSn module and then **Data** to call up the Data Window. Select the **Stop Cool Factor** field, and enter an appropriate value or accept the default.

***Via the SX Tool***

Enter a value under **OPT. ST.** at Item **OSnSBCK** (RI.16).

**Adaptive Control  
(Filter Weight)**

This is a number, expressed in percent, which defines the proportion of the latest calculated factor used to update the stored building factor. One percent is a slow update (100 days); 10% is a relatively fast update (10 days); 0% stops the update of building factors and has the same effect as disabling the adaptive process. (For information on the effect of different values, refer to the calculations under *Optimal Start/Stop Configuration*.)

***Via the GX Tool***

Select the OSn module and then **Data** to call up the Data Window. Select the **Filter Weight** field, and enter a value from 0 to 100%.

***Via the SX Tool***

Enter a value under **OPT. ST.** at Item **OSnFW** (RI.17) from 0 to 100%.

**Outdoor Air  
Design  
Temperature  
(Heating)**

This is a number, expressed in degrees, defining the coldest outdoor temperature that the heating equipment is designed to handle. When the outdoor air is below this value, the module will not update the building factors.

Note: For North American applications, these values change based on geographical location, and can be obtained from the *ASHRAE Handbook of Fundamentals*, Chapter 24, Table 1, Climatic Conditions for the United States.

***Via the GX Tool***

Select the OSn module and then **Data** to call up the Data Window. Select the **OA Design Temp Htg** field, and enter the design temperature.

***Via the SX Tool***

Enter a value under **OPT. ST.** at Item **OSnHTD** (RI.18).

**Outdoor Air  
Design  
Temperature  
(Cooling)**

This is a number, expressed in degrees, defining the warmest outdoor temperature that the cooling equipment is designed to handle. When the outdoor air is above this value, the module will not update the building factors.

Note: For North American applications, these values change based on geographical location, and can be obtained from the *ASHRAE Handbook of Fundamentals*, Chapter 24, Table 1, Climatic Conditions for the United States.

***Via the GX Tool***

Select the OSn module and then **Data** to call up the Data Window. Select the **OA Design Temp Clg** field, and enter the design temperature.

***Via the SX Tool***

Enter a value under **OPT. ST.** at Item **OSnCTD** (RI.19).

**Control Range (+/-)**

This is a number, expressed in degrees, that defines the temperature band above and below the zone air temperature setpoint within which the heating/cooling equipment is regulated. The Building Factor is not updated if the initial Zone Air Temperature is within the Control Range. See Figure 30.

***Via the GX Tool***

Select the OSn module and then **Data** to call up the Data Window. Select the **Control Range** field, and enter the temperature band.

***Via the SX Tool***

Enter a value under **OPT. ST.** at Item **OSnCRNG** (RI.20).

## Notes

1. The value in OSnTIM (RI.23) indicates the calculated startup time (in minutes) for the currently active optimal start period (during unoccupied period) or for the last optimal start period to have been active (during occupied period) (Version 1.1 or later).
2. The bit values in Item **OSnSTA** (RI.24) indicate the Operating Status as follows:

|        |         |   |
|--------|---------|---|
| X1 = 1 | OSnHLD  | puts the optimal start/stop module in Hold mode. The output of the module (OSnOUT) can be modified in the Hold mode.  |
| X2     | OSnOUT  | output status and control is the Output of the optimal start/stop module, can be used as logic input to any of the programmable or output modules, and will typically be used to start the main heating, cooling, or AHU equipment. |
| X3 = 1 | OSnHEAT | indicates when the module is in Heating mode and can be used as logic input to any of the programmable or output modules.   |
| X4 = 1 | OSnPRE  | indicates when the module is in precooling or preheating and can be used as logic input to any of the programmable or output modules.   |
| X5 = 1 | OSnSTO  | indicates that the output has been reset (OSnOUT = 0) during the optimal stop period, and can be used as a logic input to any of the programmable or output modules.  |
| X6     | OSnIN   | status of the command input (usually time schedule <b>TSnOUT</b> ).   |
| X7 = 1 | OSnADP  | adapting algorithm disabled.  |
| X8 = 1 | OSnDAS  | module disabled.  |

Status Items can be used as logic (digital) connections using the GX Tool or SX Tool.
3. Optimal Start/Stop values cannot be viewed directly from the DX front panel.

## GX Labels

### Source Points (Outputs)

- OSnHEAT** A 1 when *Optimal Start* module is in the Heating mode.
- OSnOUT** A 1 when the *Optimal Start* module requires equipment to be On. It is the controlling *output* of an *Optimal Start* module to START/STOP heating or cooling equipment.
- OSnPRE** A 1 while the *Optimal Start* module is in the Preconditioning mode (will turn Off at occupancy).
- OSnSTO** A 1 when the *Optimal Start* module is in the Optimal Stop mode (will turn Off at vacancy - unoccupied).

### Destination Points (Inputs)

- OSnDA@** The connection to *disable* the *adaptive* action of an *Optimal Start/Stop* module.
- OSnDI@** The connection to *disable* the *Optimal Start/Stop* module.
- OSnOB@** The connection to the *Off Setpoint Bias*, which replaces the entered value when connected in an *Optimal Start/Stop* module.
- OSnOT@** The connection for the *Outdoor Air Temperature* sensor of an *Optimal Start/Stop* module.
- OSnSP@** The connection for the *Optimal Start Zone Temperature setpoint*. If connected, it replaces the entered setpoint.
- OSnTS@** The connection in an *Optimal Start/Stop* module for the *time schedule* that determines when the building is occupied.
- OSnZT@** The connection for the *Zone Temperature* sensor in an *Optimal Start/Stop* module.

---

## Programmable Logic Control Configuration

### Introduction

The DX-9100 operating system provides a software-implemented Programmable Logic Controller (PLC). Every second the PLC module executes a user-defined program, which operates on a 2,048-bit memory area containing an image of the hardware digital input/outputs, logic variables from function modules, and digital constants. In the memory area each input, output, and logic variable has its own, pre-allocated address. Variables in the memory area are frozen before the execution of the program in the PLC module, and the resulting changes in the logic variables are transferred out of the memory area to the appropriate hardware or function modules at the end of the module execution.

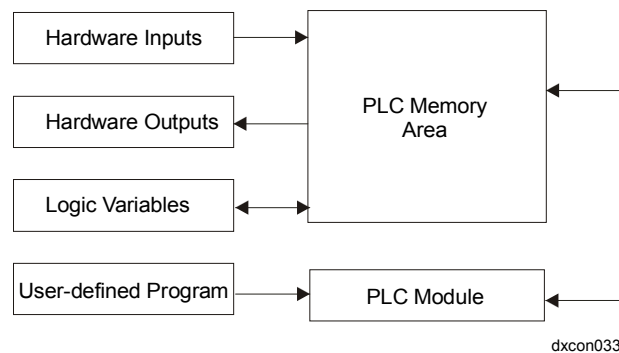

**Figure 31: Programmable Logic Control**

### PLC User-Defined Program

A user-defined program is a sequence of instruction blocks, which contains logic instructions, each leading to a PLC result status. An instruction block always begins with a LOAD or LOAD NOT (like an IF or IF NOT) logic instruction, which initializes the PLC result status, and normally terminates with an instruction performing an output to the memory area using the final result status (THEN).

LOAD and LOAD NOT instructions may also be used within an instruction block to create a logic sub block.

In the GX-9100 Graphic Programming Software, the instructions are laid out in eight pages of ladder diagrams, each containing eight lines of up to eight instructions, graphically depicted as shown below.

The following instructions are available: (1 = On, 0 = Off).

### ***Instruction LOAD***

This instruction begins the operation of an instruction block; the value of the addressed variable (0 or 1) is placed in the result status. This instruction also begins the operation of an ANDB or ORB sub block and saves the current value of the result status; the value of the addressed variable is placed in the sub block result status. (Think of LOAD as an IF statement.) In the figure below, the logic variable DI1 (Digital Input 1) is shown.

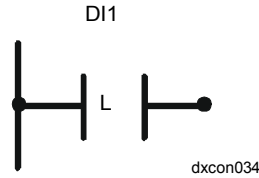

**Figure 32: Load Instruction**

**Table 8: LOAD**

| LOAD Status Of Addressed Variable | Result Status |
|-----------------------------------|---------------|
| 1                                 | 1             |
| 0                                 | 0             |
| IF                                | THEN          |

### ***Instruction LOAD NOT***

This instruction begins the operation of an instruction block; the inverted value of the addressed variable (0 or 1) is placed in the result status. This instruction also begins the operation of an ANDB or ORB sub block and saves the current value of the result status; the value of the addressed variable is placed in the sub block result status. In the figure below, the logic variable AIH8 (high alarm status of Analog Input 8) is shown.

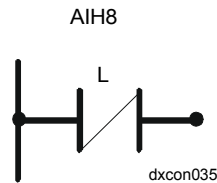

**Figure 33: Load Not Instruction**

**Table 9: LOAD NOT**

| LOAD NOT Status Of Addressed Variable | Result Status |
|---------------------------------------|---------------|
| 0                                     | 1             |
| 1                                     | 0             |
| IF NOT                                | THEN          |

### Instruction AND

This instruction calculates the logical AND between the value of the addressed variable and the result status; the result is placed in the result status. This instruction may also be used within sub blocks. In Figure 34, the logic variable DI2 (Digital Input 2) is shown.



Figure 34: AND Instruction

Table 10: AND

| Previous Result Status | AND Status of Addressed Variable | Result Status |
|------------------------|----------------------------------|---------------|
| 1                      | 1                                | 1             |
| 0                      | 1                                | 0             |
| 1                      | 0                                | 0             |
| 0                      | 0                                | 0             |
| IF                     | AND                              | THEN          |

### Instruction AND NOT

This instruction calculates the logical AND between the inverted value of the addressed variable and the result status; the result is placed in the result status. This instruction may also be used within sub blocks. In Figure 35, the logic variable DI3 (Digital Input 3) is shown.



Figure 35: AND NOT Instruction

Table 11: AND NOT

| Previous Result Status | AND NOT Status of Addressed Variable | Result Status |
|------------------------|--------------------------------------|---------------|
| 1                      | 0                                    | 1             |
| 0                      | 0                                    | 0             |
| 1                      | 1                                    | 0             |
| 0                      | 1                                    | 0             |
| IF                     | AND NOT                              | THEN          |



### Instruction OR

This instruction calculates the logical OR between the value of the addressed variable and the result status; the result is placed in the result status. This instruction may also be used within sub blocks. In Figure 36, the logic variable DI4 (Digital Input 4) is shown.

Note: Only *one* addressed variable can be OR'd, whereas an ORB allows a block of variables linked by AND and OR instructions to be OR'd.

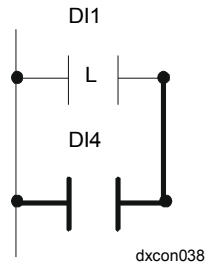

Figure 36: OR Instruction

Table 12: OR

| Previous Result Status | OR Status of Addressed Variable | Result Status |
|------------------------|---------------------------------|---------------|
| 1                      | 1                               | 1             |
| 0                      | 1                               | 1             |
| 1                      | 0                               | 1             |
| 0                      | 0                               | 0             |
| IF                     | OR                              | THEN          |

### Instruction OR NOT

This instruction calculates the logical OR between the inverted value of the addressed variable and the result status; the result is placed in the result status. This instruction may also be used within sub blocks. In Figure 37, the logic variable DI5 (Digital Input 5) is shown.

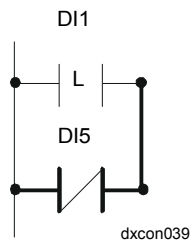

Figure 37: OR NOT Instruction

**Table 13: OR NOT**

| Previous Result Status | OR NOT | Result Status |
|------------------------|--------|---------------|
| 1                      | 0      | 1             |
| 0                      | 0      | 1             |
| 1                      | 1      | 1             |
| 0                      | 1      | 0             |
| IF                     | OR NOT | THEN          |

***Instruction ANDB (AND Block)***

This instruction terminates a logic sub block and indicates that a logical AND operation must be performed between the sub block result status and the result status saved before the execution of the sub block. No logic variable is referenced.

Note: In the GX Tool an AND Block is started with a LOAD or LOADNOT instruction and closed by an ANDB instruction.

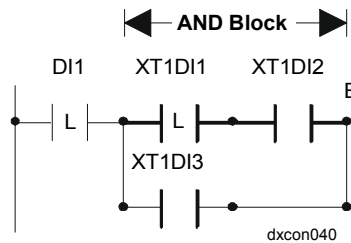

**Figure 38: AND Block Instruction**

**Table 14: AND Block**

| Previous Result Status | Sub Block Result Status | Final Result Status |
|------------------------|-------------------------|---------------------|
| 1                      | 1                       | 1                   |
| 0                      | 1                       | 0                   |
| 1                      | 0                       | 0                   |
| 0                      | 0                       | 0                   |
| IF                     | AND                     | THEN                |

**Instruction ORB**

This instruction terminates a logic sub block and indicates that a logical OR operation must be performed between the sub block result status and the result status saved before the execution of the sub block.

An ORB allows a block of variables linked by AND and OR instructions to be OR'd, whereas a single OR allows only one addressed variable to be OR'd.

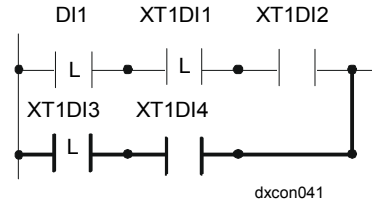

**Figure 39: OR Block Instruction**

**Table 15: ORB**

| Previous Result Status | Sub Block Result Status | Final Result Status |
|------------------------|-------------------------|---------------------|
| 1                      | 1                       | 1                   |
| 0                      | 1                       | 1                   |
| 1                      | 0                       | 1                   |
| 0                      | 0                       | 0                   |
| IF                     | OR                      | THEN                |

An OR Block may be nested within an AND Block. In this case, the ORB must come before an ANDB.

Note: In the GX Tool an ORB must be declared before defining the block to be OR'd for graphic formatting purposes.

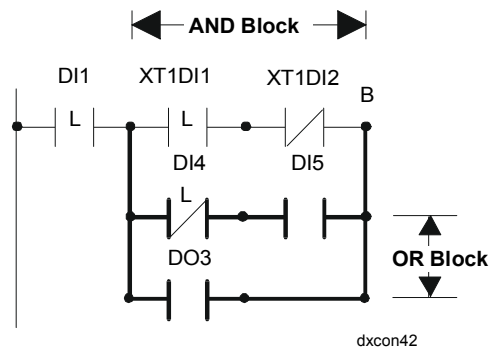

**Figure 40: OR Block Nested Within AND Block**

### ***Instruction OUT***

This instruction causes the value of the result status, obtained from the preceding logic instructions in the instruction block, to be transferred to the addressed memory location. (Think of OUT as a THEN statement.) In Figure 41, the result is transferred to the Logic Result Status Variable LRS1.

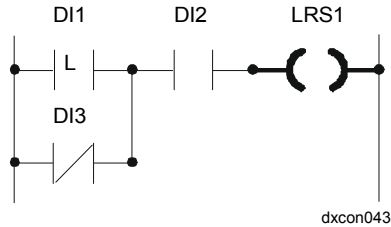

**Figure 41: OUT Instruction**

**Table 16: OUT**

| Previous Result Status | OUT to Addressed Variable |
|------------------------|---------------------------|
| 0                      | 0                         |
| 1                      | 1                         |
| IF                     | THEN                      |

### ***Instruction OUT NOT***

This instruction causes the inverted value of the result status, obtained from the preceding logic instructions in the instruction block, to be transferred to the addressed memory location. In Figure 42, the result is transferred to the Logic Result status Variable LRS2.

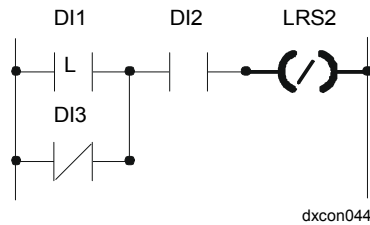

**Figure 42: OUT NOT Instruction**

**Table 17: OUT NOT**

| Previous Result Status | OUT NOT to Addressed Variable |
|------------------------|-------------------------------|
| 0                      | 1                             |
| 1                      | 0                             |
| IF                     | THEN                          |

### Instruction COS

This logic instruction is intended to detect a positive change in the value of the result status obtained from the preceding logic instructions in the instruction block. The result status calculated in the actual execution cycle is compared with the result status obtained in the previous cycle and retained in the memory location addressed in the COS instruction. If the result status has changed from a value of 0 to 1 in the actual execution cycle, the result status is set to 1; otherwise, it is set to 0.

Conditional instructions following a COS instruction will be executed only once after a change-of-state in the preceding logic expression. The instruction below detects a positive change of status.

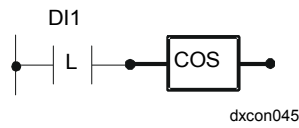

Figure 43: COS Instruction

Table 18: COS

|        | Previous Result Status | Result Status |
|--------|------------------------|---------------|
| 1 scan | 0                      | 0             |
| 2 scan | 1                      | 1             |
| 3 scan | 1                      | 0             |
| 4 scan | 1                      | 0             |
| 5 scan | 0                      | 0             |
| 6 scan | 1                      | 1             |

### Instruction SET

This instruction is executed only if the result status has a value 1 and causes the addressed memory location to be set to 1. In Figure 44, the variable LRS3 will be set if the logic block result is true.

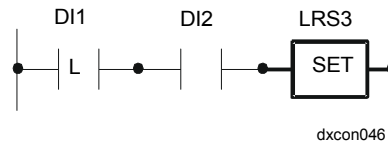

Figure 44: SET Instruction

Table 19: SET

| Previous Result Status | SET       |
|------------------------|-----------|
| 0                      | No action |
| 1                      | 1         |
| IF 1                   | THEN 1    |

Note: Normally each variable set by the PLC will also need to be reset by the PLC unless it is reset by some other module, by controller initialization, or by a BAS command.

**Instruction RST**

This instruction is executed only if the result status has a value 1 and causes the addressed memory location to be set to 0. In Figure 45, the variable LRS3 will be reset (set to 0) if the logic block result is true.

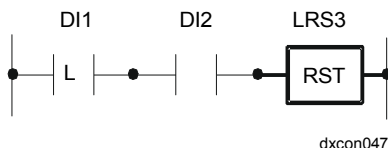

**Figure 45: RESET Instruction**

**Table 20: RST**

| Previous Result Status | RST       |
|------------------------|-----------|
| 0                      | No action |
| 1                      | 0         |
| IF 1                   | THEN 0    |

**Instruction END (SX Only)**

This instruction ends the execution of the PLC Program and sets the result status to the 0 state.

Provided that no power failure occurs, the next PLC execution cycle will begin with the logic instruction in the specified address field. This allows the skipping of initialization routines in the lowest address locations.

After a power failure, the PLC execution cycle will begin at Address 0000.

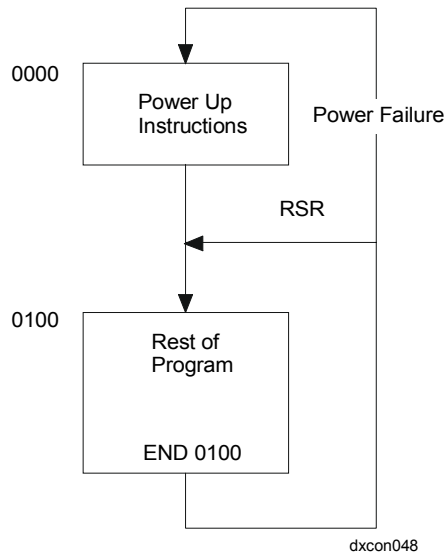

**Figure 46: END Instruction/Program Execution After Power Failure**

***Instruction RSR (GX Only)***

In the GX-9100 Graphic Configuration Software the RSR (restart) element marks the place where the PLC execution cycle will begin when there has been no power failure. Immediately upon power up, the code before and after RSR will run; consecutive scans will only run the code after RSR.

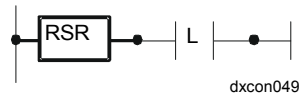

**Figure 47: RSR Block**

***Instruction NOP***

This instruction has no operation and causes the PLC to skip this line of the program. It is normally used in the GX Tool to make the logic easier to read and to fill in unused graphic elements.

### Via the GX Tool

Click on **PM** in the toolbar, select **PLC**, and position the PLC module (box) on the screen. Double-click on PLCn to enter instructions into the ladder diagram.

The instruction line consists of instructions (such as LOAD) and logic variable labels (such as DI1, Digital Input 1). Following is an example of how to construct a simple logic program using the GX Tool:

Specification: If occupied is On and the outdoor air temperature is below 55°F (12.8°C), start the hot water pump.

Clicking the mouse on the upper left dot calls up the following choices: NOP, LOAD, LOAD NOT, RSR.

Selecting LOAD is similar to typing IF:

- If occupied is On would be done in this way:

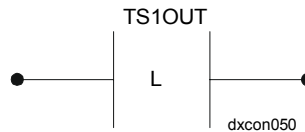

**Figure 48: If Occupied is On**

(Where load was selected by clicking on the left dot and TS1OUT, occupied was selected by clicking on |L|, then TS, then TS1OUT.)

- AND the outdoor temperature is below 55° would be done in this way:

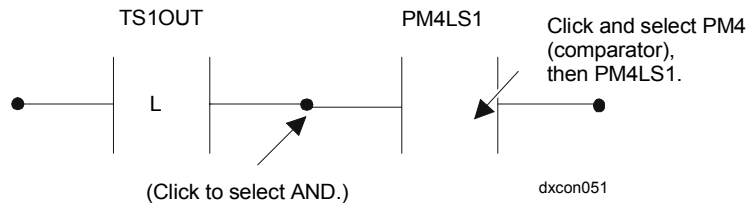

**Figure 49: AND the Outdoor Temperature is Below 55°**

Then click on the next dot to select **OUT**, as follows:

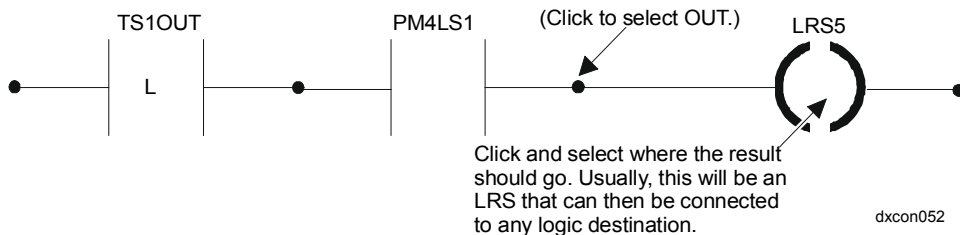

**Figure 50: Select OUT**

To complete the specification, LRS5 would be the source point of the Digital Output defined as the hot water pump.



### Via the SX Tool

Instruction lines are divided into three fields:

- field for the instruction code, such as LOAD (CODE1)
- field to select a bit in a memory logic variable byte, bit 1-8
- field to address a memory logic variable byte, such as 06 (=DIS; Digital Input Status)

Notes: Bits 1-8 of a logic variable are equal to bits X1-X8 or X9-X16 of the corresponding Item byte or word. See *Appendix D: Logic Variables* for a list of logic variables.

Visual examples of these instructions can be found earlier in this section, under *PLC User-Defined Program*.

|                         |          |         |                   |
|-------------------------|----------|---------|-------------------|
| <b>Instruction LOAD</b> | [ Code ] | [ bit ] | [ Memory Address] |
|                         | 1        | 1...8   | 0..255            |

|                             |          |         |                   |
|-----------------------------|----------|---------|-------------------|
| <b>Instruction LOAD NOT</b> | [ Code ] | [ bit ] | [ Memory Address] |
|                             | 2        | 1...8   | 0..255            |

|                        |          |         |                   |
|------------------------|----------|---------|-------------------|
| <b>Instruction AND</b> | [ Code ] | [ bit ] | [ Memory Address] |
|                        | 3        | 1...8   | 0..255            |

|                            |          |         |                   |
|----------------------------|----------|---------|-------------------|
| <b>Instruction AND NOT</b> | [ Code ] | [ bit ] | [ Memory Address] |
|                            | 4        | 1...8   | 0..255            |

|                       |          |         |                   |
|-----------------------|----------|---------|-------------------|
| <b>Instruction OR</b> | [ Code ] | [ bit ] | [ Memory Address] |
|                       | 5        | 1...8   | 0..255            |

|                           |          |         |                   |
|---------------------------|----------|---------|-------------------|
| <b>Instruction OR NOT</b> | [ Code ] | [ bit ] | [ Memory Address] |
|                           | 6        | 1...8   | 0..255            |

|                         |          |         |                   |
|-------------------------|----------|---------|-------------------|
| <b>Instruction ANDB</b> | [ Code ] | [ bit ] | [ Memory Address] |
|                         | 7        | 0       | 0                 |

|                        |          |         |                   |
|------------------------|----------|---------|-------------------|
| <b>Instruction ORB</b> | [ Code ] | [ bit ] | [ Memory Address] |
|                        | 8        | 0       | 0                 |

|                            |          |                    |                   |
|----------------------------|----------|--------------------|-------------------|
| <b>Instruction OUT</b>     | [ Code ] | [ bit ]            | [ Memory Address] |
|                            | 9        | 1...8              | 0..255            |
| <b>Instruction OUT NOT</b> | [ Code ] | [ bit ]            | [ Memory Address] |
|                            | 10       | 1...8              | 0..255            |
| <b>Instruction COS</b>     | [ Code ] | [ bit ]            | [ Memory Address] |
|                            | 11       | 1...8              | 0..255            |
| <b>Instruction SET</b>     | [ Code ] | [ bit ]            | [ Memory Address] |
|                            | 12       | 1...8              | 0..255            |
| <b>Instruction RST</b>     | [ Code ] | [ bit ]            | [ Memory Address] |
|                            | 13       | 1...8              | 0..255            |
| <b>Instruction END</b>     | [ Code ] | [ Program Address] |                   |
|                            | 31       | 0..511             |                   |
| <b>Instruction NOP</b>     | [ Code ] | [ bit ]            | [ Memory Address] |
|                            | 0        | 0                  | 0                 |

## Notes

1. The PLC program can be generated using the GX-9100 Tool. The program is laid out in the format of a Ladder Diagram and the graphic software automatically generates the program code for the PLC module. This ladder cannot be read from the DX front panel.
2. The use of the instruction codes and logic variable memory addresses is only required for the programming with the SX Tool.
3. On power up, the PLC is executed before the programmable modules. For more detailed information, refer to *Power Up Conditions - Programmable Logic Controller (PLC)*, further in this guide.
4. A series of ANDNOT statements followed by an OUTNOT statement is logically equivalent to a series of OR statements followed by an OUT statement. In the GX Tool, the use of ANDNOT statements in one line will more efficiently use the space available in the ladder logic diagram.

**PLC Program Example**

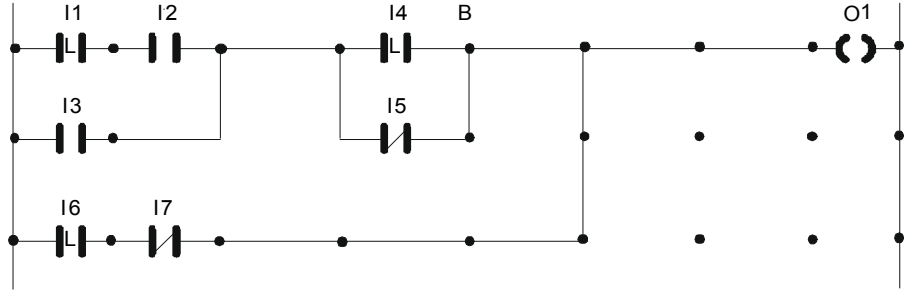

$$O1 = [((I1 * I2) + I3) * (I4 + \overline{I5})] + [I6 * \overline{I7}]$$

dxcon053

**Figure 51: Example of a PLC Program and Equivalent PLC Code**

```

LOAD    I1 ; Begin instruction block (IF Input 1 AND Input 2
AND     I2                               OR Input 3 are true.
OR      I3
NOP     ; Space
LOAD    I4 ; Begin sub block (AND)      AND
OR NOT  I5                               IF Input 4 OR NOT Input 5
ANDB    ; End sub block (AND)  are true.
NOP     ; Space
LOAD    I6 ; Begin sub block (OR)      OR
AND NOT I7                               IF Input 6 AND NOT Input 7
ORB*    ; End sub block (OR)  are true.
NOP     ; Space
NOP     ; Space
OUT     O1 ; End instruction block  THEN Output1 is On.
                                           ELSE Output1 is Off.)
:
:
END     0 ; End PLC Program

```

\*Note: In the GX Tool, an ORB must be declared before defining the block to be OR'd for graphic formatting purposes.

## Dial-up Feature with an NDM

**IMPORTANT:** Before the DX-9100 Controller can be used for dial-in alarm reporting, it must have Version 1.2, 2.1, or later firmware, and the program must be generated using the GX-9100 software program. The dial-up feature is not available with Version 3, the DX-912x LONWORKS controller.

There is no special programming or firmware required to allow the DX-9100 Controller to be used in a dial-out application where the operator is initiating the command to dial.

The DX-9100 Controller does not support COS reporting and therefore does not cause the NDM to automatically dial in. A bit, called the DIAL bit, was added to the DX-9100 with Version 1.2 or 2.1 firmware. The NDM monitors this bit to determine if an alarm condition has occurred. Once the DIAL bit is set, the NDM initiates its dial-in sequence. Special programming, similar to that shown in this application, is required to set this DIAL bit. The DIAL bit is reset by the BAS once the NDM makes a connection, and the DX-9100 Controller comes online.

The DX-9100 Controller can be used for a dial-in N2 application if the following tasks are performed:

1. Determine which points in the DX-9100 Controller (hardware or software) need to initiate the dial command sequence.
2. Program the DX-9100 such that the points chosen in Step 1 properly set the DIAL bit from within the Programmable Logic Controller (PLC).
3. Program the NDM as specified in the *NDM Configurator Application Note (LIT-6364090)* in *FAN 636.4* or *1628.4*.

For DX controllers, Versions 1.4, 2.3, and later, the dial-up feature is also used to allow the Metasys supervisory system to read trend log data for its Point History feature. The logic variable HTRR (Historical Trend Read Request) indicates when the buffers are full and must be included in the logic diagram if the trend data is required for Metasys Point History. Refer also to the section *Trend Log* further in this document.

## Choosing the Points

Because the DIAL bit is set from within the PLC, any digital point, such as a binary input or possibly an analog input's alarm status, is a valid choice. It is up to the programmer to decide which of these points, when added to the PLC, must cause the NDM to dial in and report the alarm condition. It is crucial that the points that set the DIAL bit within the PLC also exist as *alarm reporting* points in the BAS.

The following section shows the configuration needed to add the points to the PLC to set the DIAL bit.

## Configuring the Program

This application requires a dial-in to occur if either sensors, AI1 or AI3, go into a high alarm or return to normal state. In addition, a dial-in is also required if either digital input, DI1 or DI2, go into an alarm, or if the trend log buffer is full.

To do this, open a page in the PLC and enter a logic block that **ORBs** all the alarm points together and then **SETs** the DIAL bit as a result. For the return to normal alarms, it is necessary to add a LOAD NOT of the alarm condition.

The following diagram is an example of how this configuration appears in the PLC:

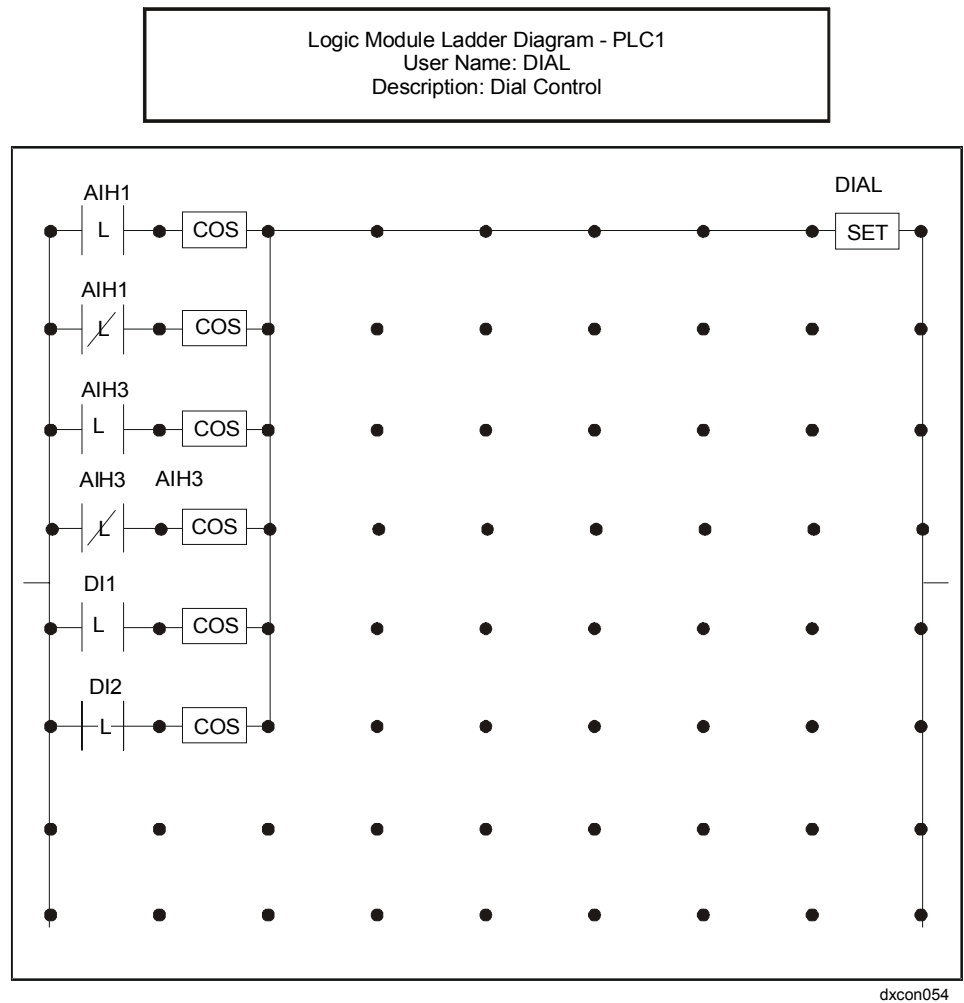

**Figure 52: Configuration Diagram**

The COS block is needed to prevent an alarm point from retriggering the DIAL bit by having a true output for only one pass of the PLC after it detects a transition from low to high. This requires the alarm point to return to normal before that COS outputs again.

When an alarm occurs, the DIAL bit is set. The remote NDM then detects the reset, causing it to dial in to the local NDM. Once communication is established, the BAS resets the dial bit.

Notes: To create the above logic, you must use an ORB rather than an OR statement. If an OR statement is used, you will not be able to AND the COS block with the alarm point.

The HTRR variable does *not* require a COS element as the Metasys system will always reset HTRR when a connection is made.

## Variations

Note that the previous example requires a line of PLC for each condition that requires a dial-in to occur. In order to conserve space in the PLC, it is possible to generate the alarms utilizing a timer. The purpose of the timer is to generate a pulse when the alarm is first detected, just as the COS block did in the previous example. The timer outputs (which indicate that an alarm has occurred) can then be used in the PLC to set the DIAL bit.

To do this, add the conditions that require a dial-in as the inputs to the timer. Define the timer as a pulse type timer with a time of 2 seconds, which gives the PLC time to detect the pulse. Use the timer outputs in the PLC to generate a pulse to an LRS. This same LRS is then used to set the DIAL bit.

This method conserves space in the PLC by performing the OR statement of up to seven alarm conditions on one line. This is done with reverse logic by ANDing a series of LOAD NOTs instead of ORing a series of LOADs.

This method is shown in the following two diagrams. Figure 53 shows how to configure the timers, Figure 54 shows how to use these timers with reverse logic in the PLC.

| TIMER (TIMER 1) - Data               |        |                        |        |
|--------------------------------------|--------|------------------------|--------|
| User Name :COS                       |        |                        |        |
| Description :TIMER USED AS COS BLOCK |        |                        |        |
| TIMER #1 TYPE                        | 1      | TIMER #5 TYPE          | 1      |
| Input Connection #1-->               | AIH1   | Input Connection #5--> | DI1    |
| Reset Connection #1-->               |        | Reset Connection #5--> |        |
| Time Period #1                       | 2.0000 | Time Period #5         | 2.0000 |
| Time Units #1                        | 0      | Time Units #5          | 0      |
| TIMER #2 TYPE                        | 1      | TIMER #6 TYPE          | 1      |
| Input Connection #2-->               | /AIH1  | Input Connection #6--> | DI2    |
| Reset Connection #2-->               |        | Reset Connection #6--> |        |
| Time Period #2                       | 2.0000 | Time Period #6         | 2.0000 |
| Time Units #2                        | 0      | Time Units #6          | 0      |
| TIMER #3 TYPE                        | 1      | TIMER #7 TYPE          | 1      |
| Input Connection #3-->               | AIH3   | Input Connection #7--> |        |
| Reset Connection #3-->               |        | Reset Connection #7--> |        |
| Time Period #3                       | 2.0000 | Time Period #7         | 2.0000 |
| Time Units #3                        | 0      | Time Units #7          | 0      |
| TIMER #4 TYPE                        | 1      | TIMER #8 TYPE          | 1      |
| Input Connection #4-->               | /AIH3  | Input Connection #8--> |        |
| Reset Connection #4-->               |        | Reset Connection #8--> |        |
| Time Period #4                       | 2.000  | Time Period #8         | 2.000  |
| Time Units #4                        | 0      | Time Units #8          | 0      |

dxcon055

**Figure 53: Timer**

Logic Module Ladder Diagram - PLC2  
 User Name: ALT-DIAL  
 Description: ALTERNATIVE DIAL METHOD

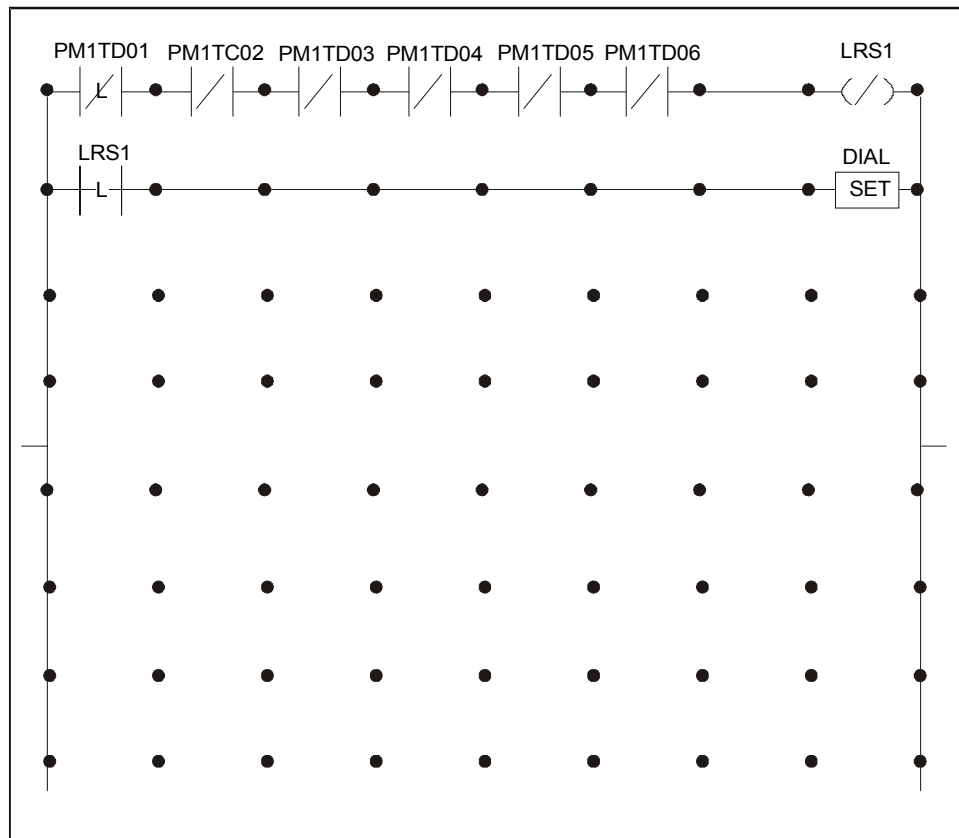

dxcon056

**Figure 54: Configuration Diagram Variation**

Notes: If more than seven alarms are required, another line in the PLC could be added which would command an additional LRS. This LRS would then be used in conjunction with the first LRS to set the DIAL bit.

The HTRR bit is only available in the PLC module (under Diagnostic) and cannot be used as a source to a Timer module.

---

**Trend Log  
(Versions 1.4,  
2.3, 3.3, or  
Later)**

**Dial** When set to 1 by a set statement in the PLC, this causes the N2 Dialer to connect the N2 Bus to a BAS via telephone lines. The Dial bit will be reset to 0 by the BAS when the telephone line connection is successful.

**Point History  
(Versions 1.4,  
2.3, or Later)**

The Trend Log module provides 12 trend log channels, each recording data from either 1 analog Item or from a set of 8 logic variables (logic variable byte). The trend can be used to provide data for Point History in DX controllers that are remote from the BAS or for a local DX LCD Display. Trend data cannot be displayed on the integral DX controller display panel, or on the GX or SX Tools.

**Trend Log for  
DX LCD Display  
(Versions 2.3,  
3.3, or Later)**

When the DX controller is connected to a BAS by an NDM Dialer and telephone lines, the trend data may be read whenever a connection is made by the BAS. The data is stored in the point history file of AI, AOs, and BI objects when they are mapped to the Items being recorded. When the Point History option is selected for a trend log channel, only those Items that can be mapped to objects are allowed and the trend parameters are set by the GX Tool to recommended default values for the Point History feature. You may change these default values, but you must take into consideration the maximum number of values that Point History can display and the frequency of the connections to the BAS via dial-up. You must link the Historical Trend Read Request logic variable to the DIAL request logic variable in a PLC module to initiate a connection when a trend record buffer is full. As a DX Version 3.x cannot be connected to a BAS by the NDM Dialer and telephone lines, trend logs cannot be configured for Point History in these versions.

Trend channels that are not used for Point History are freely configurable. For analog Items, the sampling rate may be entered and the stored values may be either the average, maximum, or minimum values during the sampling period, or the instantaneous value at the time of recording. Logic variables are recorded with a time and date stamp when there is a change of value. All channels may be displayed on the DX LCD Display.



Note: When selecting a logic variable, choose the byte that contains the required variable. All variables in the set will be then available for Point History or for the DX LCD Display. Since a logic variable set is recorded when any one of its variables changes state, you are recommended to assign LRS logic variable bytes to trend log and to connect the source variables (the ones that you wish to trend) to the LRS variables in a PLC module.

A channel of the trend log is defined by the following parameters:

**Table 21: Trend Log Parameters**

| Parameter  | Possible Values   | Default/Point History Setting in GX Tool   |
|--|---|--|
| Source Item or Logic Variable Index (byte)   | See <i>Appendix E: Analog Items and Logic Variables for the Trend Log Module.</i> | None   |
| Sampling Rate (Period of time between records)   | 5, 10, 15, 20, 30, 60 seconds or 1-1440 minutes                                   | Analog (AI): 30<br>Analog (AOS): 180<br>Logic Variables (BI): 1<br>Note: Logic variable bytes are read each second, but only recorded when there has been a change-of-state in at least one bit. |
| Sampling Rate Units  | Sec. (seconds)<br>Min. (minutes)  | Analog (AI and AOS): Min.  |
| Read Request (Number of new samples to set HTRR)<br>Note: A value of 0 disables the Read Request feature for the Item or logic variable. | Analog: 0 to 61<br>Logic Variables: 0 to 30                                       | Analog (AI): 48 Analog (AOS): 10<br>Logic Variables (BI): 10<br>Note: When Point History is <b>not</b> selected: 0   |
| Sampling mode (Analog value to record at end of each period)   | Average<br>Maximum<br>Minimum<br>Actual<br>Logic Variable                         | Actual<br>(Not applicable to logic variables)  |
| Synchronization (Exact time of the start of trend recording)   | None<br>Day (midnight 00:00:00)<br>Hour (xx:00:00)<br>Minute (xx:xx:00)           | Hour<br>(Not applicable to logic variables)  |

### ***Via the GX Tool***

Click on **PM** in the Tool Bar, then select **Trend** and position the module on the screen. Double-click on the Trend Log module block. The Trend Log definition table with 12 rows, 1 for each channel, will appear. Highlight the channel, then select **Data**.

In the dialog box check the **Point History** box if required, then enter the desired **Tag Name** of the Item or logic variable set to be recorded.

Note: Point History is not available for DX Version 3.x as this controller cannot be monitored remotely with an NDM Dialer.

One of two data windows will appear when a valid tag name has been entered, depending on whether an analog Item or logic variable set was selected.

Refer to *Appendix E: Analog Items and Logic Variables for the Trend Log Module* for a list of the tag names available in Trend Log.

Enter the desired values in the Data fields.

Note: If Point History was checked, do not change the default values unless you have a good understanding of the Point History feature. For details, refer to the *Point History Technical Bulletin (LIT-636112)* in *FAN 636*.

In any free line of a PLC module, add a LOAD element assigned to the logic variable **HTRR** (listed under DIAGNOSTIC) followed by a SET element assigned to the logic variable DIAL. If other logic variables have already been configured to set the DIAL variable, add the **HTRR** variable as an OR element to the ladder logic diagram. Refer to *Dial-up Feature with an NDM - Configuring the Program* earlier in this document for an example.

### ***Via the SX Tool***

Trend log cannot be configured with the SX Tool. However, the following Items can be read in the General Module for diagnostic purposes.

Item **DIAG** (RI.03)

**HTRR** bit X4 = 1      Historical Trend Read Request (one of the Trend Read Request bits for Channels 1 to 12 is set)

Item **TRSTA** (RI.47) Trend Status

bit Xn = 1              Trend Read Request for Channel n (n = 1 to 12)

Item **PHMAP** (RI.48) Point History Map

bit Xn = 1              Trend Channel n used for Point History (n = 1 to 12)

---

**Supervisory  
Mode Control  
Settings  
(General  
Module)**

Versions 1 and 2 of the DX-9100 Controller may be connected to a BAS using the RS-485 serial link (N2 Bus or Bus 91). The Version 3 Controller (DX-912x-8454) is connected to the NCM-350 via the LONWORKS N2 Bus. Supervisory mode control operates in the same way in all three versions.

**Access to the  
Controller**

For control access, the BAS must first set a BAS Active bit. To keep control access, the BAS must refresh that bit at a minimum of every 120 minutes. If the BAS fails or loses communication with the controller, and the bit is not refreshed, the controller returns automatically to its Standalone mode of operation.

When the BAS bit is active, the BAS has access to the supervisory parameters of the controller. It can also change numerical and logic values by addressing the respective Items in the Item list. Items stored in EEPROM may only be written to on an occasional basis (maximum of once a day).

The functions specifically related to the BAS control are as follows:

- Set a programmable function module, output module, extension module, or time schedule module to *Hold* mode.
- Set the *Shutoff* mode.
- Set the *Startup* mode.
- Set a control module to *Computer* mode.
- *Enable* supervisory control of digital outputs (triacs).
- Set digital outputs (triacs) to On or Off.

Within a control module (PID or On/Off), the output may be overridden by BAS control with the following priorities:

1. Hold mode
2. Shutoff mode (when enabled)
3. Startup mode (when enabled)
4. Computer mode

**Via the BAS**

The BAS Active bit is automatically set by BAS when connected online.

### ***Via the GX Tool***

As the GX Tool has no BAS functions, it is not necessary to set the BAS Active bit from the GX Tool.

### ***Via the SX Tool***

Set the supervisory bit at bit X16 of Item **SUP** (RI.01) (General Module).

## **Startup Mode**

The Startup mode can operate properly only if a PID or On/Off Controller is configured in Programmable Function Module 1.

To allow the Startup mode to be active in a particular module the Enable Startup mode must be set to 1.

This mode is activated and de-activated by a BAS. It is also de-activated after 120 minutes when the communication with the BAS fails.

For PID algorithms, the output will be set to a level between 0 and 100%, overriding the output limits of the control module.

For On/Off algorithms, the output will be set to a level of 0 or 1.

The Startup mode will remain active as long as the controller configured in the Programmable Function Module 1 has an absolute deviation greater than 5% of the PV range. A lower deviation will clear the startup command throughout all enabled modules.

### ***Via the BAS***

Configure using the reference STUP.

### ***Via the GX Tool***

To allow the Startup mode to be active, select PID or On/Off and then **Data** to call up the Data Window. Enter a value of 1 in the **Ena. Startup** field. (If you do not want it active, enter 0.)

To set the startup commanded value, select On/Off or PID, and then **Data** to call up the Data Window. Enter the value at the **Startup Out Level** field.

### ***Via the SX Tool***

Under **Program Modules**, set the Enable Startup mode via PM Item **PMnOPT** (RI.01) bit X3 (STAE).

Set the PID startup output at Alg. Item **STL** (RI.52).

Set On/Off startup output at PM Item **PMnOPT** (RI.01) bit X4 (STAL).

Activate or de-activate under **General Module**, by setting bit X8 of Item **SUP** (RI.01) (STUP).

The status of the mode can be seen under **Program Modules** at PM Item **PMnST** (RI.72) bit X10 (STA).

## **Shutoff Mode**

This mode is activated and deactivated by a BAS. It is also deactivated after 120 minutes when the communication with the BAS fails.

For PID algorithms, the output will be set to a level between 0 and 100%, overriding the output limits of the control module. For On/Off algorithms, the output will be set to a level of 0 or 1.

To allow the Shutoff mode to be active in a particular module, the Enable Shutoff mode must be set to 1.

In PID algorithms, if **Enable OFF Trans** is set at 1 the Shutoff mode is changed to the Off mode if  $PV < WSP$  (Off mode) in a heating controller (PB is negative), and if  $PV > WSP$  (Off mode) in a cooling controller (PB is positive).

In Shutoff mode, the control module will assume a configured output value of between 0 and 100%, overriding the output limits of the control module.

### ***Via the BAS/Companion/Facilitator***

Configure using the reference SOFF.

### ***Via the GX Tool***

To allow the Shutoff mode to be active, select PID or On/Off module, and then **Data** to call up the Data Window. Enter the value 1 in the **Ena. Shutoff** field. If you do not want the Shutoff mode to be active, leave it at 0.

To set the output value, select On/Off or PID, and then **Data** to call up the Data Window. Enter the value at the **Shutoff Out Level** field.

For the change described above, enter a 1 at **Ena OFF Trans**.

### ***Via the SX Tool***

Under **Program Modules**, set the Enable Startup mode via PM Item **PMnOPT** (RI.01) bit X1.

Set the PID output value under **Program Modules** at Alg. Item **SOL** (RI.51).

Set the On/Off output value at PM Item **PMnOPT** (RI.01) bit X2 (SOFL).

Activate and de-activate this mode under **General Module** by setting bit X7 of Item **SUP** (RI.01) (SOFF).

Set **Shutoff to Off change** under **Program Modules** at PM Item **PMnOPT** (RI.01) bit X9 (SOTO).

The status of the mode can be seen under **Program Modules** at PM Item **PMnST** (RI.72) bit X9 (SOF).

## **Hold Mode**

Each programmable function module, output module, time schedule module, or extension module can be commanded to operate in Hold mode by the BAS. It will remain active until the hold command is changed. Hold mode is not interrupted when the serial communication link fails.

Overriding from the DX front panel (using the <A/M> key), also puts certain output and programmable modules in Hold mode.

In Hold mode, the output of the module is not updated by the Control algorithm and can be directly controlled by the BAS.

Refer also to *Power Up Conditions - Hold Mode*.

### ***Via the BAS/Companion/Facilitator***

Hold modes are automatically set when overriding the output value of a programmable module, output module, or extension module.

### ***Via the GX Tool***

Modules cannot be put in Hold mode directly by the GX Tool. Hold modes may, however, be set and reset by the PLC or on power up. Refer to *Programmable Logic Control Configuration - PLC User-Defined Program*, and *Power Up Conditions - Hold Mode* in this guide.

### ***Via the SX Tool***

For each programmable function module, the control and status of Hold modes is available under **Program Modules** at PM Item **PMnHDC** (RI.70) bits X1-X8.

For time schedule modules, the control of Hold mode is available under **Time Sched TSnSTA** (RI.06) bit X1 (TSnHLD).

For analog output modules, the control of Hold mode is available under **Output Modules** at Item **AOC** (RI.07) bit X1 (OUH).

For digital output modules, the control of Hold mode is available under **Output Modules** at Item **DOC** (RI.12) bit X1 (OUH).

For extension module outputs, the control of Hold mode is available under **XT Modules** at Item **XTnHDC** (RI.69) bits X1-X8 (OUH1-8).

## **Computer Mode**

Each PID or On/Off controller can be commanded to operate in Computer mode by a BAS. It will remain active until the BAS changes the mode, or communication is lost for 120 minutes. In DX-9100 Version 1.1 or later, the Computer mode will be inactive during any period of serial link communication failure. See *Serial Link Monitoring* further in this document. The calculation of the WSP of a controller in Computer mode is no longer performed by the controller and the BAS must set the value of **WSP**. It is not possible to change the WSP from the DX front panel when Computer mode is active.

In the DX-9100 controllers, Versions 1 and 2 (firmware Version 1.1 or later), the Computer mode will also be inactive during any period of serial link communication failure. This does not apply to the DX-912x Controller, Version 3. See *Serial Link Monitoring* further in this document.

### ***Via the BAS/Companion/Facilitator***

The Computer mode is automatically set when overriding a Working Setpoint Value (WSP) in a programmable control module.

### ***Via the GX Tool***

Modules cannot be put in Computer mode directly by the GX Tool. Computer modes may, however, be set and reset by the PLC. Refer to *Programmable Logic Control Configuration - PLC User-Defined Program* in this guide.

### ***Via the SX Tool***

For each programmable function module configured as PID or On/Off controller, under **Program Modules**, set PM Item **PMnHDC** (RI.70) bit X2, then adjust **WSP** (RI.61).

### **Controlling Digital Outputs**

The BAS can control the status of the digital outputs to On or Off by directly overriding the triacs.

### ***Via the GX Tool***

The override of digital outputs cannot be controlled directly by the GX Tool.

Note: BAS commands to digital outputs do not pass through the Digital Output Modules, and therefore the DX front panel display does not follow the status of the output triac when supervisory control is enabled (see Figure 55).

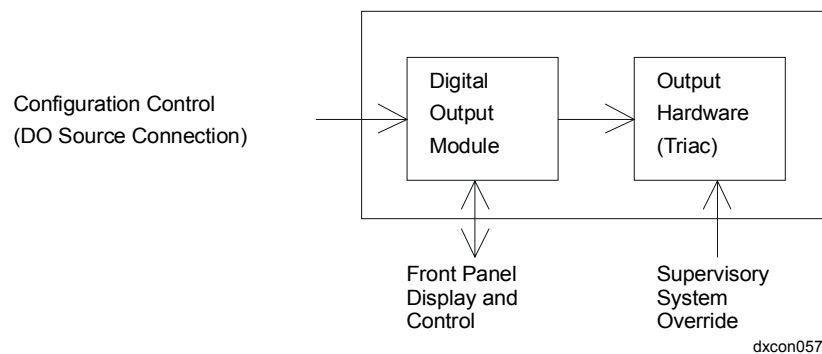

**Figure 55: Controlling Digital Outputs by BAS Override**

For On/Off type digital outputs, it is possible to display the true status of the digital output when under BAS override control by connecting the status of the digital output hardware (triac) to the source connection of the digital output module via PLC logic (see Figure 56). When the digital output override is enabled by the BAS, the output module is controlled by the status of the hardware. When the digital output override is not enabled, the output module is controlled by the configured source.



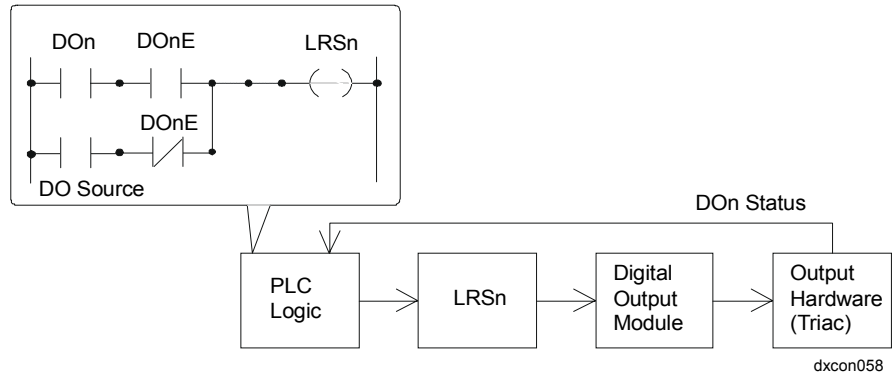

**Figure 56: Display of True Digital Output Status on DX Front Panel when under BAS Override Control**

**Via the SX Tool**

First, the SX may enable control of the six digital (triac) outputs of the controller by setting bits X9 to X14 of Item **SUP** (RI.01) under **General Module**.

Control the triacs On or Off by setting bits X1 to X6 of Item **SUP** (RI.01) (under **General Module**) to 1 or 0, respectively.

The status of the triacs can be seen under **General Module** at Item **TOS** (RI.05) X1=D03...X6=D08.

**Maintenance Control**

When any parameter is changed in the controller, Maintenance Started (under General Module, bit X1 of Item **MNT** (RI.02)) will be set as the change is started and Maintenance Stopped, bit X2 of Item **MNT** (RI.02), will be set as the change is completed. Changes can be made from the front panel, a service module, or the DX LCD Display. These bits can only be reset by a command from BASs and are used to alert a remote operator that changes have been made.

**Via the BAS**

Configure using the reference MNT. (Not available on Companion/Facilitator Systems.)

**Via GX Tool (Versions 1.4, 2.3, 3.3, or Later)**

In the PLC, the MNT variable is listed under DIAGNOSTIC and represents Maintenance Stopped.

**Via SX Tool**

The logic variables may be seen under General Module as follows:

- Item MNT (RI.02)    X1 = 1 Maintenance Started
- X2 = 1 Maintenance Stopped

## Counter Size

Four bytes have been allocated for counter data in the controller and a value of up to 9,999,999 can be displayed on the front panel of the controller. Certain BASs (Metasys system, for example) only read the least significant 15 bits and provide extensive facilities to store counter data in computer memory, on diskette, or tape. To enable the synchronization of the DX-9100 display panel with BASs, the reset of counter values can be configured as follows:

### ***Via the GX Tool***

Select **Edit-Global Data**. Under **Counter Type**, mark the 15-bit (Metasys system) or 4-byte field.

### ***Via the SX Tool***

Under **General Module**, Item DXS1 (RI.32), set bit X4 as follows:

X4 = 0 Select 15-bit counters (Counter resets at 32,767)

X4 = 1 Select 4-byte counters (Counter resets at 9,999,999)

## Serial Link Monitoring

There are two logic variables available in the Version 1 or 2 controller, which indicate the status of the BAS and the serial link. They may be used in the PLC to enable standalone control sequencers or local time schedules, for example. Only the logic variable SSA is available in the Version 3 controller.

The logic variable SSA (BAS Active) is set by the BAS to enable the supervisory functions of the controller. This logic variable must be set by the BAS at least every two hours as the controller will automatically reset the bit two hours after the last update. The SSA bit indicates that the BAS has been active within the last two hours, or that the BAS has *not* been active for a period of more than two hours. When the SSA bit is not set, the following BAS control modes are automatically cancelled:

Shutoff mode                      Computer mode

Startup mode                      Digital Outputs Enable and Command

The logic variable SLF (Serial Link Failure) (not available in the Version 3 controller) indicates the status of the serial link independently of any BAS functions. In a Version 1 or 2 DX-9100, the bit is reset when the N2 Bus serial link communications are good, and set when the N2 Bus serial link communications have been absent or unreadable for a period of more than one minute.

In a DX-912x (Firmware Version 3), the SLF bit is not used and is always reset. When the SLF bit is set, the following BAS Control mode is not active:

Computer mode (Firmware Version 1.1 or later)

### **Via GX Tool**

In the PLC, the SSA variable is listed under **SUPERV** and the SLF variable is listed under **DIAGNOSTIC**.

Note: **DIAGNOSTIC** will be available in GX Tool versions later than Version 3.0.

### **Via SX Tool**

The logic variables may be seen in the **General Module** as follows:

Item SUP (RI.01)

X16 = 0 SSA BAS Not Active (after two hours)

X16 = 1 BAS Active

Item DIAG (RI.03)

X5 = 0 SLF Serial Link OK

X5 = 1 Serial Link Failure (after one minute)

### **GX Labels**

#### **Points for PLC**

**DOnC** A 1 when the BAS has commanded the *digital output* to be On.

**DOnE** A 1 when the BAS has taken control of the *digital output*.

**MNT** A 1 when an Item has been change from the front panel, service module or DX LCD Display.

**SLF** Serial Link Failure. Set to 1 60 seconds after the last message from the BAS.

**SOFF** A 1 when the BAS has commanded the Shutoff mode.

**SSA** A 1 when the BAS is *active*, and returns to 0 two hours after the last command from the BAS.

**STUP** A 1 when the BAS has commanded the Startup mode.

**SLF** Serial Link Failure. Set to 1 60 seconds after the last message from the BAS.

---

**Controller  
Diagnostics**

There are four logic variables available in the controller to provide diagnostic information. The first is the serial link failure condition (SLF) described above. The second indicates when the internal lithium battery has discharged to approximately 20% of its initial capacity (BATLOW). The third indicates that a trend log buffer has reached its read request limit (HTRR) as described under *Trend Log*. The fourth is the Maintenance Control Item described above.

**Logic Variables****Via GX Tool**

In the SLF, BATLOW, HTRR, and MNT variables are listed under **DIAGNOSTIC**.

Note: **DIAGNOSTIC** will be available in the GX Tool versions later than Version 3.0.

**Via SX Tool**

The logic variables may be seen in the General Module under Item DIAG (RI.03):

|        |        |  |
|--------|--------|--|
| X2 = 0 | BATLOW | lithium battery OK                     |
| X2 = 1 | BATLOW | lithium battery low charge             |
| X4 = 1 | HTRR   | one or more trend log buffers are full |
| X5 = 0 | SLF    | serial link OK                         |
| X5 = 1 | SLF    | serial link failure (after one minute) |

The MNT variable may be seen in the General Module under Item MNT (RI.02).

**GX Labels**

|               |  |
|---------------|--|
| <b>BATLOW</b> | A 1 when the DX lithium battery needs to be replaced.                                    |
| <b>HTRR</b>   | A 1 when one or more trend log buffers is full.  |
| <b>MNT</b>    | A 1 when an Item has been change from the front panel, service module or DX LCD Display. |
| <b>SLF</b>    | Serial Link Failure. Set to 1 60 seconds after the last message from the BAS.            |

---

**Power Up  
Conditions**

When the controller is powered up after a 24 VAC power interruption, various operating modes can be set or reset to allow a predetermined startup sequence of control operations.

**Hold Mode**

At power up, output modules can be set to Hold mode, reset from Hold mode (set to 0), or may retain the last mode before power failure. These commands take priority over the Supervisory mode command initialization described in the next section, *Supervisory Mode Commands Initialization*.

### Via the GX Tool

For analog outputs, select **AOn** and then **Data** to call up the Data Window. For digital outputs, select **DOn** and then **Data** to call up the Data Window (only for PAT or DAT modules).

Note: The Hold mode for DO On/Off, PULSE, or STA/STO modules can only be configured via the SX Tool.

At the **Hold on Powerup (0=N)** field, when 1 is entered, the module will be put in hold on power up. The Hold mode can be released back to auto control from a BAS, the SX, the PLC, or via the DX front panel.

At the **Auto on Powerup (0=N)** field, when 1 is entered, the module will release this module's Hold mode on power up.

If *both* are 1, then the Hold setting takes precedence.

If *both* are 0, the Hold mode status will not be changed on Power Up (it will remain in the same state as prior to the power failure), unless the **Init. On PowerUp** has been set (as described under *Supervisory Mode Commands Initialization* below).

### Via the SX Tool

**Table 22: Configuration Bits for Hold Mode Power Up Control**

| Module                         | Configuration Bits                           |
|--------------------------------|--|
| Analog Output Modules (RI.00)  | (AOTn, X7, X8) Under <b>Output Modules</b> . |
| Digital Output Modules (RI.00) | (DOTn, X7, X8) Under <b>Output Modules</b> . |

The desired settings are made in the Item and bits shown above.

bit X8 = 0 The Hold mode is not altered after a power failure.  
(See the *DX-9100 Global Data* section in the beginning of this document.)

bit X8 = 1 The Hold mode is set at power up to the status set in bit X7.

bit X7 = 0 The Hold mode is set to hold at power up if bit X8 is set.

bit X7 = 1 The Hold mode is reset (set to 0) at power up if bit X8 is set.

### Supervisory Mode Commands Initialization

The BAS control settings can be programmed to remain set after a power failure or to be initialized to Off after a power failure.

The Hold on Power Up and Auto on Power Up take priority for AO, DAT, and PAT modules over the Init. on Power Up command.

### ***Via the GX Tool***

Select **Edit-Global Data**. Under **Init. On PowerUp**, select maintained or cancelled.

maintained=        Retain BAS commands

cancelled =        Release BAS commands

### ***Via the SX Tool***

Under **General Module DX-9100 Type Settings**, set bit X8 of Item **DXS1 (RI.32)** as follows:

X8 = 0    No initialization on power up

X8 = 1    Initialize on power up

## **Programmable Logic Controller (PLC)**

At power up, the PLC always runs from the first instruction in the program. Special power up routines should therefore be configured at the beginning of the program. These routines will not be executed in subsequent program cycles when the address of the first non-power up instruction is entered in the END instruction. In the GX-9100 Tool, the location of the first non-power up instruction is marked by the RSR element in the ladder diagram.

Power up routines may be used, for example, to set or reset Hold modes based upon prevailing conditions at the time of power up, to set timers to provide a sequential startup of equipment, or to prevent the startup of equipment until building conditions have stabilized after the return of power. Refer to the *Programmable Logic Control Configuration* section of this document, as well as to the *Programmable Logic Control* section in the *DX-9100 Extended Digital Controller Technical Bulletin (LIT 6364020)* in *FAN 636.4* or *1628.4*.

---

## ***Download/Upload***

### **Download via the N2 Bus (Versions 1 and 2 Only)**

#### ***Via the GX Tool***

Connect an RS-232-C/RS-485 converter (type MM-CVT101-x in North America and type IU-9100-810x in Europe) to one of the serial communication ports (COM1 or COM2) of the personal computer on which the GX Tool is running. Connect the N2 Bus of the DX-9100 to the converter unit connected to the PC.

Set the address switches and jumpers on the DX-9100 and XT/XTM/XP devices (if used) as required, and connect the XT/XTM/XP devices to the XT Bus of the DX-9100.

If the DX-9100 (and XT/XTM/XP devices) are installed and wired, verify all field wiring and sensor voltage/current signals. It is recommended that controlled devices be isolated during download and initial startup.

Note: Do not download an untested configuration into an installed device. Test the configuration on a simulator panel before downloading.

Apply 24 VAC power to the DX-9100 and the XT/XTM/XP devices, if connected.

On the GX Tool, with the needed configuration on screen, select **Action - Download**, and then the Item to be downloaded, as in Table 23.

**Table 23: Downloading, Versions 1 and 2**

| Configuration        | Items to be Downloaded  |
|----------------------|---|
| <b>DX and XT/XTM</b> | Downloads complete configuration to DX and all configured XT/XTMs (all configured XT/XTMs must be online).<br>Note: This option <i>must</i> be selected when downloading a DX with XT//XTMs for the first time. |
| <b>DX</b>            | Downloads all configuration information required by DX (all configured XT/XTMs must be online, but XT/XTM information is not downloaded).   |
| <b>XT/XTM</b>        | Downloads all configuration information required by XT/XTM (excludes DX information).   |
| <b>Calibration</b>   | Downloads calibration information only.<br>Note: Ensure that the correct calibration information for the connected controller is contained in the configuration on screen.                                      |
| <b>Time</b>          | Downloads the current PC clock time.  |

Enter the DX-9100 address (0-255) in the **Address** field. Under **Port**, select the PC serial communication port (Com 1 or 2).

DX Version 1.4, 2.3, 3.3, or later: Enter the password code if the configuration in the controller has been protected by a password.

Click on **OK** to confirm entries.

Checks are made before the data is downloaded to the controller. The user may abort the download process by selecting **CANCEL**.

**Download via RS-232-C Port (Versions 2 and 3 Only)**

***Via the GX Tool***

Connect the serial communication port of the PC directly to the RS-232-C port of the DX-9100 Controller. See *DX-9100 Extended Digital Controller Technical Bulletin (LIT-6364020)* in *FAN 636.4* or *1628.4* for details. Proceed as above in the *Download via the N2 Bus (Versions 1 and 2 Only)* section.

### Version 3 Only

Select the Item to be downloaded, as in the table below.

**Table 24: Downloading, Version 3**

| Configuration              | Items to be Downloaded   |
|----------------------------|--|
| <b>DX, XT/XTM, Network</b> | Downloads complete configuration to DX, including LONWORKS Network input/output information, and to all configured XT/XTMs (all configured XT/XTMs must be online).<br>Note: This option <b>must</b> be selected when downloading a Version 3 DX with or without XT/XTMs for the first time. |
| <b>DX</b>                  | Downloads all configuration information required by DX, excluding LONWORKS Network input/output information, and XT/XTM information.   |
| <b>XT/XTM</b>              | Downloads all configuration information required by XT/XTM (excludes DX information).  |
| <b>Network</b>             | Downloads LONWORKS Network input/output information only.  |
| <b>Calibration</b>         | Downloads calibration information only.<br>Note: Ensure that the correct calibration information for the connected controller is contained in the configuration on screen.   |
| <b>Time</b>                | Downloads the current PC clock time.   |

### Upload via the N2 Bus or RS-232-C Port

#### **Via the GX Tool**

Only complete DX-9100/XT-9100/XTM-905 configurations should be uploaded from the DX-9100. Select **Action - Upload**, and then the Item to be uploaded, for example, DX and XT/XTM. Enter the DX-9100 address (0-255) in the Address field. Under Port, select the PC serial communication port (Com 1 or 2).

DX Version 1.4, 2.3, 3.3, or later: Enter the password code if the configuration in the controller has been protected by a password.

Click on **OK** to confirm entries.

If the configuration in the controller matches that on the GX Tool screen, the parameters will be uploaded from the controller and replace those in the GX Tool configuration. If the configuration does not match that on the GX Tool screen, the user will be prompted to save the displayed GX Tool configuration and save the uploaded configuration to another file.

#### **Via the SX Tool**

The configuration entered into the DX-9100 Controller may be stored in the service module as an algorithm for transfer to another controller when not protected by a password.

Refer to the *SX-9120 Service Module User's Guide (LIT-6364070)* in *FAN 636.4* for further details.



---

**Calibration  
Values**

Each DX-9100 Controller has a set of unique calibration values, which are set in the factory before delivery. These calibration values are stored in EEPROM and it will not normally be necessary to change or reenter these values during the life of the controller. If the user wishes to secure the calibration data on diskette, the calibration values may be uploaded and downloaded using the GX Tool.

If it becomes necessary to recalibrate the inputs and outputs of a controller, this can be done using the SX Tool. See the *SX-9100 Service Module User's Guide (LIT-6364070)* in *FAN 636.4*.

**Upload/  
Download****Via the GX Tool**

Connect the DX-9100 Controller to the PC as described under *Download/Upload*.

To upload the calibration values, on the GX Tool select **File**, then **New** to clear the PC screen. Select **Action**, then **Upload**. Select **Calibration** and **PC Port** (1 or 2). Enter the DX-9100 Controller address (0-255). Press Enter. When the upload is complete, press Enter, reselect **File** and then **Save**. Save the uploaded calibration values in a file unique for this controller.

To download calibration values, select **File** and then **Open**. Open the file with the calibration values unique to this controller. Select **Action** and **Download**. Select **Calibration** and **PC Port** (1 or 2). Enter the DX-9100 Controller address (0-255). Press Enter.

For more details, refer to the *GX-9100 Software Configuration Tool User's Guide (LIT-6364060)* in *FAN 636.4* or *1628.4*.



# Appendix A: SX Tool Item Description and Tables

---

---

## *Description of Items*

### **Item Address**

A configuration is comprised of a set of parameters stored in a series of memory locations in the controller. These parameters are called Items. Each Item is assigned an Item address.

Active parameters such as counter values are stored in RAM, and configuration parameters are stored in EEPROM. Data stored in EEPROM type memory is retained even when no battery power is available.

A memory area with a certain range of Item addresses for its parameters or Items has been assigned to each module.

Each Item within this range has been assigned a Relative Item (RI.) address from which its absolute address can be determined.

The absolute address of an Item is the sum of the starting address of the module range and the relative Item address. When using the GX Tool for the DX-9100, the user refers to module tags and numbers, and Item tags or relative addresses. Absolute addresses are not normally required.

Note: When using the GX Tool for the DX-9100, the user refers only to module and Item tags. Absolute and relative addresses are used in the SX Tool.

## Item Type

The information stored in the Items can have one of several formats:

Floating Point Numerical Items are real numbers, with a +/- sign. They refer to input or output values, setpoint values, proportional band values, limit values, etc. They are displayed and entered as numbers, with a sign and a decimal point. These Items are shown in the Item List with **Number** in the **Type** column.

Integer Items are positive whole numbers used as scale factors. These Items are shown in the All Item List with **1 Byte Int** or **2 Byte Int** in the **Type** column.

Totalized Numerical Items are real positive numbers. They refer to totalized values such as pulse counters and accumulators. They are displayed and entered as whole numbers, without sign and decimal point. These Items are shown in the Item List with **4 Bytes** in the **Type** column.

Software Connections show to which Item or logic variable address the Item is connected. This information is entered as numbers representing the address of the connected Item or the index and bit position of a logic variable. A 0 de-selects the connection. These Items are shown in the Item List with **Connection** in the **Type** column.

Destinations are 2-byte Items, which show the destination address and type of network analog and digital outputs. A 0 represents no destination. These Items are shown in the Item List with **Destination** in the **Type** column.

Status Items are either 1-byte or 2-byte Items giving information on the actual status or configuration of the modules (Control, Logic, Calculation, Input, or Output), where each bit has a specific meaning as described in the Item List. These Items are shown in the Item List with the number of bytes in the **Type** column. Data is displayed and entered as bytes. In the list, the bytes are represented using X1-X8 or X1-X16:

|           |     |     |     |     |     |     |     |    |
|-----------|-----|-----|-----|-----|-----|-----|-----|----|
| 1 Byte =  | X8  | X7  | X6  | X5  | X4  | X3  | X2  | X1 |
| 2 Bytes = | X16 | X15 | X14 | X13 | X12 | X11 | X10 | X9 |
|           | X8  | X7  | X6  | X5  | X4  | X3  | X2  | X1 |

## Read/Write Data

The Items shown in the Item List can be divided into three basic categories:

- Input values and status of the controller that can be read but not changed by a BAS. These Items are shown in the Item List with an **R** in the **R/W** (Read/Write) column.
- Variables in the controller that can be read and modified by the SX-9100 Service Module, GX-9100 Graphic Configuration Software, or BAS. These Items are shown on the Item List with an **R/W** in the **R/W** (Read/Write) column. (E) indicates that the Item is stored in EEPROM.
- All other Items in the DX-9100 refer to configuration parameters of the controller and contain information such as analog ranges, module type, connections, etc., and they can only be changed using the SX-9120 Service Module or the GX-9100 Graphic Configuration Software Tool. These Items are shown in the Item List with a **CNF** in the **R/W** (Read/Write) column.

---

## Item List

Each constant, variable, or value inside a DX-9100 Controller can be addressed through an Item code; the Item List describes all the possible Items.

## Symbols

**Table 25: Symbols Used in the Item List**

| Symbol          | Definition   |        |                             |
|-----------------|--|--------|-----------------------------|
| <b>RI.</b>      | Relative Item Index from the beginning of the module                         |        |                             |
| <b>Type</b>     | Item Type  |        |                             |
| <b>R/W</b>      | Read/Write Conditions:   | R      | Read Only Item              |
|                 |  | R/W    | Read/Write Item             |
|                 |  | R/W(E) | Read/Write Item (EEPROM)    |
|                 |  | CNF    | Configuration Item (EEPROM) |
| <b>Tag</b>      | Label for General Item or bit within an Item                                 |        |                             |
| <b>PM Tag</b>   | Generic Label for Programmable Function Module Item or bit within an Item    |        |                             |
| <b>Alg. Tag</b> | Configured Label for Programmable Function Module Item or bit within an Item |        |                             |

**Item Type**

The format of any DX-9100 Item is described by the following types:

- Number: Floating point number (2 bytes)
- 1 Byte: Unsigned 8-bit hexadecimal number used to transfer logic states or integer numbers 0-255.
- 2 Bytes: Unsigned 16-bit hexadecimal number used to transfer logic states or unsigned integer numbers 0-65535.
- 4 Byte: Unsigned 32-bit hexadecimal number used to transfer unsigned integer numbers (counters and accumulators).

Connection: Module input software connection (2 bytes).

The numeric or logic variable used as a source (input) for a configurable module is defined via a word with the following format:

**Table 26: For a Logic Connection**

|            |     |     |     |  |     |     |    |  |
|------------|-----|-----|-----|--|-----|-----|----|--|
| X16        | X15 | X14 | X13 | X12  | X11 | X10 | X9 |  |
| X8         | X7  | X6  | X5  | X4   | X3  | X2  | X1 |  |
| X8 ... X1  |     |     |     | Index of Source as in Variable List (Hex.) |     |     |    |  |
| X11 X10 X9 |     |     |     | bit Position (0-7)                         |     |     |    |  |
| X12 = 0    |     |     |     |  |     |     |    |  |
| X13 = 0    |     |     |     |  |     |     |    |  |
| X14 = 0    |     |     |     |  |     |     |    |  |
| X15 = 1    |     |     |     | Logic Connection                           |     |     |    |  |
| X16 = 1    |     |     |     | Reverse Variable Value                     |     |     |    |  |

**Table 27: For an Analog Connection**

|            |     |     |     |  |     |     |    |  |
|------------|-----|-----|-----|--|-----|-----|----|--|
| X16        | X15 | X14 | X13 | X12  | X11 | X10 | X9 |  |
| X8         | X7  | X6  | X5  | X4   | X3  | X2  | X1 |  |
| X12 ... X1 |     |     |     | Item Address of Source as Listed In Items List |     |     |    |  |
| X15 = 0    |     |     |     | Analog Connection                              |     |     |    |  |
| X16 = 1    |     |     |     | Negate Variable Value                          |     |     |    |  |

A 0 represents no connection.

Destination (2 Bytes)

The destination address for network outputs is defined via a word with the following format:

**Table 28: For a Network Digital Output Destination**

|              |     |     |     |  |     |     |    |  |
|--------------|-----|-----|-----|--|-----|-----|----|--|
| X16          | X15 | X14 | X13 | X12                                    | X11 | X10 | X9 |  |
| X8           | X7  | X6  | X5  | X4                                     | X3  | X2  | X1 |  |
| X8 ... X1    |     |     |     | Destination Controller Address (1-255) |     |     |    |  |
| X13 ... X9   |     |     |     | Destination Input Number (1-8)         |     |     |    |  |
| X15 X14 = 01 |     |     |     | System 91 Device                       |     |     |    |  |
| X16 = 1      |     |     |     | Digital Output                         |     |     |    |  |

**Table 29: For a Network Analog Output Destination**

|              |     |     |     |  |     |     |    |  |
|--------------|-----|-----|-----|--|-----|-----|----|--|
| X16          | X15 | X14 | X13 | X12                                    | X11 | X10 | X9 |  |
| X8           | X7  | X6  | X5  | X4                                     | X3  | X2  | X1 |  |
| X8 ... X1    |     |     |     | Destination Controller Address (1-255) |     |     |    |  |
| X13 ... X9   |     |     |     | Destination Input Number (1-16)        |     |     |    |  |
| X15 X14 = 01 |     |     |     | System 91 Device                       |     |     |    |  |
| X16 = 0      |     |     |     | Analog Output                          |     |     |    |  |

A 0 represents no destination.

***Floating Point Numbers***

A DX-9100 floating point number consists of two bytes with following format:

**Table 30: Floating Point Numbers**

|    |    |    |    |    |     |    |    |    |    |    |    |    |    |    |    |
|----|----|----|----|----|-----|----|----|----|----|----|----|----|----|----|----|
| 15 | 14 | 13 | 12 | 11 | 10  | 9  | 8  | 7  | 6  | 5  | 4  | 3  | 2  | 1  | 0  |
| E3 | E2 | E1 | E0 | S  | M10 | M9 | M8 | M7 | M6 | M5 | M4 | M3 | M2 | M1 | M0 |

where: EEEE = 4-bit exponent  
 S = sign (1=negative)  
 MMMMMMMMMMMM = 11-bit mantissa

- A number is normalized when the most significant bit is true (M10 = 1).
- A number is zero when all bits of the mantissa are 0.
- The value of a number is:  
 $\langle \text{NUMBER} \rangle = \langle \text{SIGN} \rangle * .\langle \text{MANTISSA} \rangle * 2^{\text{exp } \langle \text{EXPONENT} \rangle}$

**Table 31: Floating Point Number Examples**

|     |   |       |    |       |
|-----|---|-------|----|-------|
| 1   | = | 1400H | or | B001H |
| -1  | = | 1C00H | or | B801H |
| 100 | = | 7640H | or | B064H |

***EEPROM Items***

When writing Items from a BAS, it is important to note that EEPROM Items can only be written approximately 10,000 times, so that cyclical processes in the BAS that result in a write command must be avoided.





# Appendix B: Item Structure

## General Module Items Structure

**Table 32: Module**

| First | Decimal | Module Name            |
|-------|---------|------------------------|
| 0000H | 0000    | General Control Module |

**Table 33: Description**

| RI.                                 | Type    | R/W | Tag            | Description   |     |     |    |  |
|-------------------------------------|---------|-----|----------------|---|-----|-----|----|--|
| 00                                  | 1 Byte  | R   | UNIT           | Device Model: Version 1.x 05H<br>Version 2.x 15H<br>Version 3.x 25H |     |     |    |  |
| 01                                  | 2 Bytes | R/W | SUP            | Supervisory Central Control   |     |     |    |  |
| X16                                 | 0       | X14 | X13            | X12   | X11 | X10 | X9 |  |
| X8                                  | X7      | X6  | X5             | X4  | X3  | X2  | X1 |  |
|                                     | X1 = 1  |     | DO3C           | Set Output 3 On   |     |     |    |  |
|                                     | X2 = 1  |     | DO4C           | Set Output 4 On   |     |     |    |  |
|                                     | X3 = 1  |     | DO5C           | Set Output 5 On   |     |     |    |  |
|                                     | X4 = 1  |     | DO6C           | Set Output 6 On   |     |     |    |  |
|                                     | X5 = 1  |     | DO7C           | Set Output 7 On   |     |     |    |  |
|                                     | X6 = 1  |     | DO8C           | Set Output 8 On   |     |     |    |  |
|                                     | X7 = 1  |     | SOFF<br>(SOFC) | Shutoff Mode Command  |     |     |    |  |
|                                     | X8 = 1  |     | STUP<br>(STAC) | Startup Mode Command  |     |     |    |  |
|                                     | X9 = 1  |     | DO3E           | Enable Output 3 Supervisory Control                                 |     |     |    |  |
|                                     | X10 = 1 |     | DO4E           | Enable Output 4 Supervisory Control                                 |     |     |    |  |
|                                     | X11 = 1 |     | DO5E           | Enable Output 5 Supervisory Control                                 |     |     |    |  |
|                                     | X12 = 1 |     | DO6E           | Enable Output 6 Supervisory Control                                 |     |     |    |  |
|                                     | X13 = 1 |     | DO7E           | Enable Output 7 Supervisory Control                                 |     |     |    |  |
|                                     | X14 = 1 |     | DO8E           | Enable Output 8 Supervisory Control                                 |     |     |    |  |
|                                     | X15 =   |     | DIAL           | Dial-Up Flag  |     |     |    |  |
|                                     | X16 = 1 |     | SSA            | BAS Active  |     |     |    |  |
| 02                                  | 1 Byte  | R/W | MNT            | Maintenance Control   |     |     |    |  |
| 0                                   | 0       | 0   | 0              | 0   | 0   | X2  | X1 |  |
|                                     | X1 = 1  |     |                | Maintenance Started   |     |     |    |  |
|                                     | X2 = 1  |     |                | Maintenance Stopped   |     |     |    |  |
| 03                                  | 2 Byte  | R   | DIAG           | Diagnostics   |     |     |    |  |
| 0                                   | 0       | 0   | 0              | 0   | 0   | 0   | 0  |  |
| 0                                   | 0       | 0   | X5             | 0   | X3  | X2  | X1 |  |
|                                     | X1 = 1  |     | EEPROM         | EEPROM Failure (Version 2.0 or Later)                               |     |     |    |  |
|                                     | X2 = 1  |     | BATLOW         | Battery Backup Low  |     |     |    |  |
| <b>Continued on next page . . .</b> |         |     |                |   |     |     |    |  |

| RI.<br>(Cont.)                      | Type   | R/W | Tag     | Description   |    |    |    |  |  |
|-------------------------------------|--------|-----|---------|---|----|----|----|--|--|
|                                     | X3 = 1 |     | EPROM   | EPROM Checksum Failure<br>(Version 2.0 or Later)                          |    |    |    |  |  |
|                                     | X4 = 1 |     | HTRR    | Historical Trend Read Request<br>(Versions 1.4, 2.3, or Later)            |    |    |    |  |  |
|                                     | X5 = 1 |     | SLF     | Serial Link Failure<br>(not active and Computer Mode<br>disabled)         |    |    |    |  |  |
|                                     | X6=1   |     | DWNLD   | Download Mode is active   |    |    |    |  |  |
|                                     | X7=1   |     | DEVIRST | Device Reset has occurred   |    |    |    |  |  |
|                                     | X8=1   |     | PASS    | Password Protection is active   |    |    |    |  |  |
|                                     |        |     |         |   |    |    |    |  |  |
| 04                                  | 1 Byte | R   | DICT    | Digital Input Counters  |    |    |    |  |  |
| X8                                  | X7     | X6  | X5      | X4  | X3 | X2 | X1 |  |  |
|                                     | X1 = 1 |     | DIC1    | Count Transition on DI1   |    |    |    |  |  |
|                                     | X2 = 1 |     | DIC2    | Count Transition on DI2   |    |    |    |  |  |
|                                     | X3 = 1 |     | DIC3    | Count Transition on DI3   |    |    |    |  |  |
|                                     | X4 = 1 |     | DIC4    | Count Transition on DI4   |    |    |    |  |  |
|                                     | X5 = 1 |     | DIC5    | Count Transition on DI5   |    |    |    |  |  |
|                                     | X6 = 1 |     | DIC6    | Count Transition on DI6   |    |    |    |  |  |
|                                     | X7 = 1 |     | DIC7    | Count Transition on DI7   |    |    |    |  |  |
|                                     | X8 = 1 |     | DIC8    | Count Transition on DI8   |    |    |    |  |  |
|                                     |        |     |         |   |    |    |    |  |  |
| 05                                  | 1 Byte | R   | TOS     | TRIAC Output Status   |    |    |    |  |  |
| 0                                   | 0      | X6  | X5      | X4  | X3 | X2 | X1 |  |  |
|                                     | X1 = 1 |     | DO3     | Output 3 is On  |    |    |    |  |  |
|                                     | X2 = 1 |     | DO4     | Output 4 is On  |    |    |    |  |  |
|                                     | X3 = 1 |     | DO5     | Output 5 is On  |    |    |    |  |  |
|                                     | X4 = 1 |     | DO6     | Output 6 is On  |    |    |    |  |  |
|                                     | X5 = 1 |     | DO7     | Output 7 is On  |    |    |    |  |  |
|                                     | X6 = 1 |     | DO8     | Output 8 is On  |    |    |    |  |  |
|                                     | X8=1   |     | XTERR   | Failure in any connected XT/XTM (only<br>versions 1.5, 2.5, 3.5 or later) |    |    |    |  |  |
| 06                                  | 1 Byte | R   | DIS     | Digital Input Status  |    |    |    |  |  |
| X8                                  | X7     | X6  | X5      | X4  | X3 | X2 | X1 |  |  |
|                                     | X1 = 1 |     | DI1     | Digital Input 1 is On   |    |    |    |  |  |
|                                     | X2 = 1 |     | DI2     | Digital Input 2 is On   |    |    |    |  |  |
|                                     | X3 = 1 |     | DI3     | Digital Input 3 is On   |    |    |    |  |  |
|                                     | X4 = 1 |     | DI4     | Digital Input 4 is On   |    |    |    |  |  |
|                                     | X5 = 1 |     | DI5     | Digital Input 5 is On   |    |    |    |  |  |
|                                     | X6 = 1 |     | DI6     | Digital Input 6 is On   |    |    |    |  |  |
|                                     | X7 = 1 |     | DI7     | Digital Input 7 is On   |    |    |    |  |  |
|                                     | X8 = 1 |     | DI8     | Digital Input 8 is On   |    |    |    |  |  |
| <b>Continued on next page . . .</b> |        |     |         |   |    |    |    |  |  |

| RI.<br>(Cont.)                      |     | Type    |     |     |     | R/W |    | Tag   |  | Description                  |  |
|-------------------------------------|-----|---------|-----|-----|-----|-----|----|-------|--|------------------------------|--|
| 07                                  |     | 2 Byte  |     |     |     | R   |    | AIS   |  | Analog Input Status          |  |
| X16                                 | X15 | X14     | X13 | X12 | X11 | X10 | X9 |       |  |                              |  |
| X8                                  | X7  | X6      | X5  | X4  | X3  | X2  | X1 |       |  |                              |  |
|                                     |     | X1 = 1  |     |     |     |     |    | AIH1  |  | High Alarm Condition         |  |
|                                     |     | X2 = 1  |     |     |     |     |    | AIL1  |  | Low Alarm Condition          |  |
|                                     |     | X3 = 1  |     |     |     |     |    | AIH2  |  | High Alarm Condition         |  |
|                                     |     | X4 = 1  |     |     |     |     |    | AIL2  |  | Low Alarm Condition          |  |
|                                     |     | X5 = 1  |     |     |     |     |    | AIH3  |  | High Alarm Condition         |  |
|                                     |     | X6 = 1  |     |     |     |     |    | AIL3  |  | Low Alarm Condition          |  |
|                                     |     | X7 = 1  |     |     |     |     |    | AIH4  |  | High Alarm Condition         |  |
|                                     |     | X8 = 1  |     |     |     |     |    | AIL4  |  | Low Alarm Condition          |  |
|                                     |     | X9 = 1  |     |     |     |     |    | AIH5  |  | High Alarm Condition         |  |
|                                     |     | X10 = 1 |     |     |     |     |    | AIL5  |  | Low Alarm Condition          |  |
|                                     |     | X11 = 1 |     |     |     |     |    | AIH6  |  | High Alarm Condition         |  |
|                                     |     | X12 = 1 |     |     |     |     |    | AIL6  |  | Low Alarm Condition          |  |
|                                     |     | X13 = 1 |     |     |     |     |    | AIH7  |  | High Alarm Condition         |  |
|                                     |     | X14 = 1 |     |     |     |     |    | AIL7  |  | Low Alarm Condition          |  |
|                                     |     | X15 = 1 |     |     |     |     |    | AIH8  |  | High Alarm Condition         |  |
|                                     |     | X16 = 1 |     |     |     |     |    | AIL8  |  | Low Alarm Condition          |  |
| 08                                  |     | 2 Byte  |     |     |     | R   |    | LRST1 |  | Logic Results                |  |
| X16                                 | X15 | X14     | X13 | X12 | X11 | X10 | X9 |       |  |                              |  |
| X8                                  | X7  | X6      | X5  | X4  | X3  | X2  | X1 |       |  |                              |  |
|                                     |     | X1 = 1  |     |     |     |     |    | LRS1  |  | Logic Result Status 1 is On  |  |
|                                     |     | X2 = 1  |     |     |     |     |    | LRS2  |  | Logic Result Status 2 is On  |  |
|                                     |     | X3 = 1  |     |     |     |     |    | LRS3  |  | Logic Result Status 3 is On  |  |
|                                     |     | X4 = 1  |     |     |     |     |    | LRS4  |  | Logic Result Status 4 is On  |  |
|                                     |     | X5 = 1  |     |     |     |     |    | LRS5  |  | Logic Result Status 5 is On  |  |
|                                     |     | X6 = 1  |     |     |     |     |    | LRS6  |  | Logic Result Status 6 is On  |  |
|                                     |     | X7 = 1  |     |     |     |     |    | LRS7  |  | Logic Result Status 7 is On  |  |
|                                     |     | X8 = 1  |     |     |     |     |    | LRS8  |  | Logic Result Status 8 is On  |  |
|                                     |     | X9 = 1  |     |     |     |     |    | LRS9  |  | Logic Result Status 9 is On  |  |
|                                     |     | X10 = 1 |     |     |     |     |    | LRS10 |  | Logic Result Status 10 is On |  |
|                                     |     | X11 = 1 |     |     |     |     |    | LRS11 |  | Logic Result Status 11 is On |  |
|                                     |     | X12 = 1 |     |     |     |     |    | LRS12 |  | Logic Result Status 12 is On |  |
|                                     |     | X13 = 1 |     |     |     |     |    | LRS13 |  | Logic Result Status 13 is On |  |
|                                     |     | X14 = 1 |     |     |     |     |    | LRS14 |  | Logic Result Status 14 is On |  |
|                                     |     | X15 = 1 |     |     |     |     |    | LRS15 |  | Logic Result Status 15 is On |  |
|                                     |     | X16 = 1 |     |     |     |     |    | LRS16 |  | Logic Result Status 16 is On |  |
| <b>Continued on next page . . .</b> |     |         |     |     |     |     |    |       |  |                              |  |

| RI.<br>(Cont.)                      |     | Type    | R/W | Tag              | Description               |     |    |  |
|-------------------------------------|-----|---------|-----|------------------|---------------------------|-----|----|--|
| 09                                  |     | 2 Byte  | R   | LRST2            | Logic Results             |     |    |  |
| X16                                 | X15 | X14     | X13 | X12              | X11                       | X10 | X9 |  |
| X8                                  | X7  | X6      | X5  | X4               | X3                        | X2  | X1 |  |
|                                     |     |         |     | LRS17 -<br>LRS32 | Logic Result Status 17-32 |     |    |  |
| 10                                  |     | 2 Byte  | R/W | LCOS1            | Logic Constants           |     |    |  |
| X16                                 | X15 | X14     | X13 | X12              | X11                       | X10 | X9 |  |
| X8                                  | X7  | X6      | X5  | X4               | X3                        | X2  | X1 |  |
|                                     |     | X1 = 1  |     | DCO1             | Digital Constant 1 is On  |     |    |  |
|                                     |     | X2 = 1  |     | DCO2             | Digital Constant 2 is On  |     |    |  |
|                                     |     | X3 = 1  |     | DCO3             | Digital Constant 3 is On  |     |    |  |
|                                     |     | X4 = 1  |     | DCO4             | Digital Constant 4 is On  |     |    |  |
|                                     |     | X5 = 1  |     | DCO5             | Digital Constant 5 is On  |     |    |  |
|                                     |     | X6 = 1  |     | DCO6             | Digital Constant 6 is On  |     |    |  |
|                                     |     | X7 = 1  |     | DCO7             | Digital Constant 7 is On  |     |    |  |
|                                     |     | X8 = 1  |     | DCO8             | Digital Constant 8 is On  |     |    |  |
|                                     |     | X9 = 1  |     | DCO9             | Digital Constant 9 is On  |     |    |  |
|                                     |     | X10 = 1 |     | DCO10            | Digital Constant 10 is On |     |    |  |
|                                     |     | X11 = 1 |     | DCO11            | Digital Constant 11 is On |     |    |  |
|                                     |     | X12 = 1 |     | DCO12            | Digital Constant 12 is On |     |    |  |
|                                     |     | X13 = 1 |     | DCO13            | Digital Constant 13 is On |     |    |  |
|                                     |     | X14 = 1 |     | DCO14            | Digital Constant 14 is On |     |    |  |
|                                     |     | X15 = 1 |     | DCO15            | Digital Constant 15 is On |     |    |  |
|                                     |     | X16 = 1 |     | DCO16            | Digital Constant 16 is On |     |    |  |
| 11                                  |     | 2 Byte  | R/W | LCOS2            | Logic Constants           |     |    |  |
| X16                                 | X15 | X14     | X13 | X12              | X11                       | X10 | X9 |  |
| X8                                  | X7  | X6      | X5  | X4               | X3                        | X2  | X1 |  |
|                                     |     |         |     | DCO17 -<br>DCO32 | Digital Constant 17-32    |     |    |  |
| <b>Continued on next page . . .</b> |     |         |     |                  |                           |     |    |  |

| RI.<br>(Cont.)                      | Type       | R/W | Tag   | Description                      |                        |   |   |  |
|-------------------------------------|------------|-----|-------|----------------------------------|------------------------|---|---|--|
| 12                                  | 2 Byte Int | R   | VER   | Version Level of Firmware        |                        |   |   |  |
| 13                                  | 4 Bytes    | R/W | CNTR1 | DI1 Pulse Count                  |                        |   |   |  |
| 14                                  | 4 Bytes    | R/W | CNTR2 | DI2 Pulse Count                  |                        |   |   |  |
| 15                                  | 4 Bytes    | R/W | CNTR3 | DI3 Pulse Count                  |                        |   |   |  |
| 16                                  | 4 Bytes    | R/W | CNTR4 | DI4 Pulse Count                  |                        |   |   |  |
| 17                                  | 4 Bytes    | R/W | CNTR5 | DI5 Pulse Count                  |                        |   |   |  |
| 18                                  | 4 Bytes    | R/W | CNTR6 | DI6 Pulse Count                  |                        |   |   |  |
| 19                                  | 4 Bytes    | R/W | CNTR7 | DI7 Pulse Count                  |                        |   |   |  |
| 20                                  | 4 Bytes    | R/W | CNTR8 | DI8 Pulse Count                  |                        |   |   |  |
| 21                                  | 2 Bytes    | CNF | spare |                                  |                        |   |   |  |
| 22                                  | 1 Byte Int | CNF | PC1   | Prescaler DI1 Counter            |                        |   |   |  |
| 23                                  | 1 Byte Int | CNF | PC2   | Prescaler DI2 Counter            |                        |   |   |  |
| 24                                  | 1 Byte Int | CNF | PC3   | Prescaler DI3 Counter            |                        |   |   |  |
| 25                                  | 1 Byte Int | CNF | PC4   | Prescaler DI4 Counter            |                        |   |   |  |
| 26                                  | 1 Byte Int | CNF | PC5   | Prescaler DI5 Counter            |                        |   |   |  |
| 27                                  | 1 Byte Int | CNF | PC6   | Prescaler DI6 Counter            |                        |   |   |  |
| 28                                  | 1 Byte Int | CNF | PC7   | Prescaler DI7 Counter            |                        |   |   |  |
| 29                                  | 1 Byte Int | CNF | PC8   | Prescaler DI8 Counter            |                        |   |   |  |
| 30                                  | 1 Byte     | CNF | spare |                                  |                        |   |   |  |
| 31                                  | Connection | CNF | ALD@  | Alarm Disable Condition Source   |                        |   |   |  |
| 32                                  | 1 Byte     | CNF | DXS1  | DX9100 Type Settings             |                        |   |   |  |
| X8                                  | X7         | X6  | X5    | X4                               | 0                      | 0 | 0 |  |
|                                     | X4 = 0     |     |       |                                  | 15-bit Counters        |   |   |  |
|                                     | X4 = 1     |     |       |                                  | 4-byte Counters        |   |   |  |
|                                     | X6 X5      |     |       |                                  | Extension Bus Timing   |   |   |  |
|                                     | = 00       |     |       |                                  | XT-9100 Default        |   |   |  |
|                                     | = 01       |     |       |                                  | XTM-905 Default        |   |   |  |
|                                     | = 10       |     |       |                                  | 200 msec               |   |   |  |
|                                     | = 11       |     |       |                                  | 300 msec               |   |   |  |
|                                     | X7 = 0     |     |       |                                  | 50 Hz Power Line       |   |   |  |
|                                     | X7 = 1     |     |       |                                  | 60 Hz Power Line       |   |   |  |
|                                     | X8 = 1     |     |       |                                  | Initialize on Power Up |   |   |  |
| 33                                  | 2 Byte Int | CNF | ALG   | Algorithm (Configuration) Number |                        |   |   |  |
| 34                                  | Number     | R/W | ACO1  | Analog Constant 1                |                        |   |   |  |
| 35                                  | Number     | R/W | ACO2  | Analog Constant 2                |                        |   |   |  |
| 36                                  | Number     | R/W | ACO3  | Analog Constant 3                |                        |   |   |  |
| 37                                  | Number     | R/W | ACO4  | Analog Constant 4                |                        |   |   |  |
| 38                                  | Number     | R/W | ACO5  | Analog Constant 5                |                        |   |   |  |
| <b>Continued on next page . . .</b> |            |     |       |                                  |                        |   |   |  |

| RI.<br>(Cont.)                           | Type    | R/W     | Tag   | Description                          |     |     |    |                       |                           |
|--|---------|---------|-------|--------------------------------------|-----|-----|----|-----------------------|---------------------------|
| 39                                       | Number  | R/W     | ACO6  | Analog Constant 6                    |     |     |    |                       |                           |
| 40                                       | Number  | R/W     | ACO7  | Analog Constant 7                    |     |     |    |                       |                           |
| 41                                       | Number  | R/W     | ACO8  | Analog Constant 8                    |     |     |    |                       |                           |
| 42                                       | 1 Byte  | R/W     | PLCNT | PLC Control and Status               |     |     |    |                       |                           |
| X8                                       | X7      | 0       | 0     | 0                                    | X3  | X2  | X1 |                       |                           |
|  |         | X1 = 1  |       |                                      |     |     |    | Set Hold Mode         |                           |
|  |         | X2 = 1  |       |                                      |     |     |    | Set Single-step Mode  |                           |
|  |         | X3 = 1  |       |                                      |     |     |    | Execute One PLC Step  |                           |
|  |         | X7 = 1  |       |                                      |     |     |    | Program Error         |                           |
|  |         | X8 = 1  |       |                                      |     |     |    | PLC Partial Result    |                           |
| 43                                       | 2 Bytes | R       | PLCPC | PLC Program Counter                  |     |     |    |                       |                           |
| 44                                       | 2 Bytes | R/W     | LRST3 | Logic Results (Version 1.1 or Later) |     |     |    |                       |                           |
| X16                                      | X15     | X14     | X13   | X12                                  | X11 | X10 | X9 |                       |                           |
| X8                                       | X7      | X6      | X5    | X4                                   | X3  | X2  | X1 |                       |                           |
|  |         |         |       |                                      |     |     |    | LRS33 - LRS48         | Logic Result Status 33-48 |
| 45                                       | 2 Bytes | R/W     | LRST4 | Logic Results (Version 1.1 or Later) |     |     |    |                       |                           |
| X16                                      | X15     | X14     | X13   | X12                                  | X11 | X10 | X9 |                       |                           |
| X8                                       | X7      | X6      | X5    | X4                                   | X3  | X2  | X1 |                       |                           |
|  |         |         |       |                                      |     |     |    | LRS49 - LRS64         | Logic Result Status 49-64 |
| <b>Versions 1.4, 2.3, 3.3, or Later:</b> |         |         |       |                                      |     |     |    |                       |                           |
| 46                                       | 2 Bytes | R/W     | DXS2  | DX-9100 Type Settings (not used)     |     |     |    |                       |                           |
| 47                                       | 2 Bytes | R       | TRSTA | Trend Status                         |     |     |    |                       |                           |
| 0  | 0       | 0       | 0     | X12                                  | X11 | X10 | X9 |                       |                           |
| X8                                       | X7      | X6      | X5    | X4                                   | X3  | X2  | X1 |                       |                           |
|  |         | X1 = 1  |       |                                      |     |     |    | Trend Read Request 1  |                           |
|  |         | X2 = 1  |       |                                      |     |     |    | Trend Read Request 2  |                           |
|  |         | X3 = 1  |       |                                      |     |     |    | Trend Read Request 3  |                           |
|  |         | X4 = 1  |       |                                      |     |     |    | Trend Read Request 4  |                           |
|  |         | X5 = 1  |       |                                      |     |     |    | Trend Read Request 5  |                           |
|  |         | X6 = 1  |       |                                      |     |     |    | Trend Read Request 6  |                           |
|  |         | X7 = 1  |       |                                      |     |     |    | Trend Read Request 7  |                           |
|  |         | X8 = 1  |       |                                      |     |     |    | Trend Read Request 8  |                           |
|  |         | X9 = 1  |       |                                      |     |     |    | Trend Read Request 9  |                           |
|  |         | X10 = 1 |       |                                      |     |     |    | Trend Read Request 10 |                           |
|  |         | X11 = 1 |       |                                      |     |     |    | Trend Read Request 11 |                           |
|  |         | X12 = 1 |       |                                      |     |     |    | Trend Read Request 12 |                           |
| <b>Continued on next page . . .</b>      |         |         |       |                                      |     |     |    |                       |                           |

| RI.<br>(Cont.) | Type    | R/W | Tag   | Description       |     |    |    |                                 |
|----------------|---------|-----|-------|-------------------|-----|----|----|---------------------------------|
| 48             | 2 Bytes | R/W | PHMAP | Point History Map |     |    |    |                                 |
| 0              | 0       | 0   | X12   | X11               | X10 | X9 |    |                                 |
| X8             | X7      | X6  | X5    | X4                | X3  | X2 | X1 |                                 |
|                | X1 = 1  |     |       |                   |     |    |    | Trend 1 used for Point History  |
|                | X2 = 1  |     |       |                   |     |    |    | Trend 2 used for Point History  |
|                | X3 = 1  |     |       |                   |     |    |    | Trend 3 used for Point History  |
|                | X4 = 1  |     |       |                   |     |    |    | Trend 4 used for Point History  |
|                | X5 = 1  |     |       |                   |     |    |    | Trend 5 used for Point History  |
|                | X6 = 1  |     |       |                   |     |    |    | Trend 6 used for Point History  |
|                | X7 = 1  |     |       |                   |     |    |    | Trend 7 used for Point History  |
|                | X8 = 1  |     |       |                   |     |    |    | Trend 8 used for Point History  |
|                | X9 = 1  |     |       |                   |     |    |    | Trend 9 used for Point History  |
|                | X10 = 1 |     |       |                   |     |    |    | Trend 10 used for Point History |
|                | X11 = 1 |     |       |                   |     |    |    | Trend 11 used for Point History |
|                | X12 = 1 |     |       |                   |     |    |    | Trend 12 used for Point History |

**Programmable  
Function  
Module Items  
Structure**

**Table 34: Programmable Function Module Items Structure**

| First | Decimal | Module Name                     |
|-------|---------|---------------------------------|
| 0040H | 0064    | Programmable Function Module 01 |
| 00A0H | 0160    | Programmable Function Module 02 |
| 0100H | 0256    | Programmable Function Module 03 |
| 0160H | 0352    | Programmable Function Module 04 |
| 01C0H | 0448    | Programmable Function Module 05 |
| 0220H | 0544    | Programmable Function Module 06 |
| 0280H | 0640    | Programmable Function Module 07 |
| 02E0H | 0736    | Programmable Function Module 08 |
| 0340H | 0832    | Programmable Function Module 09 |
| 03A0H | 0928    | Programmable Function Module 10 |
| 0400H | 1024    | Programmable Function Module 11 |
| 0460H | 1120    | Programmable Function Module 12 |

Note: TAG PMnTYP is programmable function module type of Module n.

| RI.                                 | Type       | R/W     | Tag     | Description                          |
|-------------------------------------|------------|---------|---------|--------------------------------------|
| 00                                  | 1 Byte     | CNF     | PMnTYP  | Programmable Function Module Type    |
| 01                                  | 2 Bytes    | CNF     | PMnOPT  | Programmable Function Module Options |
| 02                                  | 1 Byte     | CNF     | PMnF1   | Function Channel 1 - F1              |
| 03                                  | 1 Byte     | CNF     | PMnF2   | Function Channel 2 - F2              |
| 04                                  | 1 Byte     | CNF     | PMnF3   | Function Channel 3 - F3              |
| 05                                  | 1 Byte     | CNF     | PMnF4   | Function Channel 4 - F4              |
| 06                                  | 1 Byte     | CNF     | PMnF5   | Function Channel 5 - F5              |
| 07                                  | 1 Byte     | CNF     | PMnF6   | Function Channel 6 - F6              |
| 08                                  | 1 Byte     | CNF     | PMnF7   | Function Channel 7 - F7              |
| 09                                  | 1 Byte     | CNF     | PMnF8   | Function Channel 8 - F8              |
| 10                                  | Connection | CNF     | PMnI1@  | Input Connection - I@1               |
| 11                                  | Connection | CNF     | PMnI2@  | Input Connection - I@2               |
| 12                                  | Connection | CNF     | PMnI3@  | Input Connection - I@3               |
| 13                                  | Connection | CNF     | PMnI4@  | Input Connection - I@4               |
| 14                                  | Connection | CNF     | PMnI5@  | Input Connection - I@5               |
| 15                                  | Connection | CNF     | PMnI6@  | Input Connection - I@6               |
| 16                                  | Connection | CNF     | PMnI7@  | Input Connection - I@7               |
| 17                                  | Connection | CNF     | PMnI8@  | Input Connection - I@8               |
| 18                                  | Connection | CNF     | PMnI9@  | Input Connection - I@9               |
| 19                                  | Connection | CNF     | PMnI10@ | Input Connection - I@10              |
| 20                                  | Connection | CNF     | PMnI11@ | Input Connection - I@11              |
| 21                                  | Connection | CNF     | PMnI12@ | Input Connection - I@12              |
| 22                                  | Connection | CNF     | PMnI13@ | Input Connection - I@13              |
| 23                                  | Connection | CNF     | PMnI14@ | Input Connection - I@14              |
| 24                                  | Connection | CNF     | PMnI15@ | Input Connection - I@15              |
| 25                                  | Connection | CNF     | PMnI16@ | Input Connection - I@16              |
| 26                                  | Number     | R/W (E) | PMnK1   | Module Constant - K1                 |
| 27                                  | Number     | R/W (E) | PMnK2   | Module Constant - K2                 |
| 28                                  | Number     | R/W (E) | PMnK3   | Module Constant - K3                 |
| 29                                  | Number     | R/W (E) | PMnK4   | Module Constant - K4                 |
| 30                                  | Number     | R/W (E) | PMnK5   | Module Constant - K5                 |
| 31                                  | Number     | R/W (E) | PMnK6   | Module Constant - K6                 |
| 32                                  | Number     | R/W (E) | PMnK7   | Module Constant - K7                 |
| 33                                  | Number     | R/W (E) | PMnK8   | Module Constant - K8                 |
| 34                                  | Number     | R/W (E) | PMnK9   | Module Constant - K9                 |
| 35                                  | Number     | R/W (E) | PMnK10  | Module Constant - K10                |
| 36                                  | Number     | R/W (E) | PMnK11  | Module Constant - K11                |
| 37                                  | Number     | R/W (E) | PMnK12  | Module Constant - K12                |
| 38                                  | Number     | R/W (E) | PMnK13  | Module Constant - K13                |
| 39                                  | Number     | R/W (E) | PMnK14  | Module Constant - K14                |
| 40                                  | Number     | R/W (E) | PMnK15  | Module Constant - K15                |
| 41                                  | Number     | R/W (E) | PMnK16  | Module Constant - K16                |
| <b>Continued on next page . . .</b> |            |         |         |                                      |



| RI.<br>(Cont.) | Type   | R/W     | Tag    | Description              |    |    |    |                                  |
|----------------|--------|---------|--------|--------------------------|----|----|----|----------------------------------|
| 42             | Number | R/W (E) | PMnK17 | Module Constant - K17    |    |    |    |                                  |
| 43             | Number | R/W (E) | PMnK18 | Module Constant - K18    |    |    |    |                                  |
| 44             | Number | R/W (E) | PMnK19 | Module Constant - K19    |    |    |    |                                  |
| 45             | Number | R/W (E) | PMnK20 | Module Constant - K20    |    |    |    |                                  |
| 46             | Number | R/W (E) | PMnK21 | Module Constant - K21    |    |    |    |                                  |
| 47             | Number | R/W (E) | PMnK22 | Module Constant - K22    |    |    |    |                                  |
| 48             | Number | R/W (E) | PMnK23 | Module Constant - K23    |    |    |    |                                  |
| 49             | Number | R/W (E) | PMnK24 | Module Constant - K24    |    |    |    |                                  |
| 50             | Number | R/W (E) | PMnK25 | Module Constant - K25    |    |    |    |                                  |
| 51             | Number | R/W (E) | PMnK26 | Module Constant - K26    |    |    |    |                                  |
| 52             | Number | R/W (E) | PMnK27 | Module Constant - K27    |    |    |    |                                  |
| 53             | Number | R/W (E) | PMnK28 | Module Constant - K28    |    |    |    |                                  |
| 54             | Number | R/W (E) | PMnK29 | Module Constant - K29    |    |    |    |                                  |
| 55             | Number | R/W (E) | PMnK30 | Module Constant - K30    |    |    |    |                                  |
| 56             | Number | R/W (E) | PMnK31 | Module Constant - K31    |    |    |    |                                  |
| 57             | Number | R/W (E) | PMnK32 | Module Constant - K32    |    |    |    |                                  |
| 58             | Number | R/W (E) | PMnK33 | Module Constant - K33    |    |    |    |                                  |
| 59             | Number | R/W (E) | PMnK34 | Module Constant - K34    |    |    |    |                                  |
| 60             | Number | R/W     | PMnOU1 | Output - Channel 1       |    |    |    |                                  |
| 61             | Number | R/W     | PMnOU2 | Output - Channel 2       |    |    |    |                                  |
| 62             | Number | R/W     | PMnOU3 | Output - Channel 3       |    |    |    |                                  |
| 63             | Number | R/W     | PMnOU4 | Output - Channel 4       |    |    |    |                                  |
| 64             | Number | R/W     | PMnOU5 | Output - Channel 5       |    |    |    |                                  |
| 65             | Number | R/W     | PMnOU6 | Output - Channel 6       |    |    |    |                                  |
| 66             | Number | R/W     | PMnOU7 | Output - Channel 7       |    |    |    |                                  |
| 67             | Number | R/W     | PMnOU8 | Output - Channel 8       |    |    |    |                                  |
| 68             | Number | R       | PMnAX1 | Auxiliary Output 1       |    |    |    |                                  |
| 69             | Number | R       | PMnAX2 | Auxiliary Output 2       |    |    |    |                                  |
| 70             | 1 Byte | R/W     | PMnHDC | Hold Mode Control/Status |    |    |    |                                  |
| X8             | X7     | X6      | X5     | X4                       | X3 | X2 | X1 |                                  |
|                | X1 = 1 |         |        |                          |    |    |    | Hold Channel 1                   |
|                | X2 = 1 |         |        |                          |    |    |    | Hold Channel 2                   |
|                | X3 = 1 |         |        |                          |    |    |    | Hold Channel 3                   |
|                | X4 = 1 |         |        |                          |    |    |    | Hold Channel 4                   |
|                | X5 = 1 |         |        |                          |    |    |    | Hold Channel 5                   |
|                | X6 = 1 |         |        |                          |    |    |    | Hold Channel 6                   |
|                | X7 = 1 |         |        |                          |    |    |    | Hold Channel 7                   |
|                | X8 = 1 |         |        |                          |    |    |    | Hold Channel 8                   |
|                |        |         |        |                          |    |    |    |                                  |
| 71             | 1 Byte |         | R/W    | PMnDO                    |    |    |    | Logic Outputs Control and Status |
| X8             | X7     | X6      | X5     | X4                       | X3 | X2 | X1 |                                  |
|                | X1 = 1 |         |        |                          |    |    |    | DO Channel 1 is On               |
|                | X2 = 1 |         |        |                          |    |    |    | DO Channel 2 is On               |
|                | X3 = 1 |         |        |                          |    |    |    | DO Channel 3 is On               |
|                | X4 = 1 |         |        |                          |    |    |    | DO Channel 4 is On               |
|                |        |         |        |                          |    |    |    |                                  |

Continued on next page . . .

| RI.<br>(Cont.) | Type    | R/W | Tag    | Description                         |     |     |    |  |
|----------------|---------|-----|--------|-------------------------------------|-----|-----|----|--|
|                | X5 = 1  |     |        | DO Channel 5 is On                  |     |     |    |  |
|                | X6 = 1  |     |        | DO Channel 6 is On                  |     |     |    |  |
|                | X7 = 1  |     |        | DO Channel 7 is On                  |     |     |    |  |
|                | X8 = 1  |     |        | DO Channel 8 is On                  |     |     |    |  |
| 72             | 2 Bytes | R   | PMnST  | Programmable Function Module Status |     |     |    |  |
| X16            | X15     | X14 | X13    | X12                                 | X11 | X10 | X9 |  |
| X8             | X7      | X6  | X5     | X4                                  | X3  | X2  | X1 |  |
| 73             | 4 Bytes | R/W | PMnAC1 | Accumulator 1                       |     |     |    |  |
| 74             | 4 Bytes | R/W | PMnAC2 | Accumulator 2                       |     |     |    |  |
| 75             | 4 Bytes | R/W | PMnAC3 | Accumulator 3                       |     |     |    |  |
| 76             | 4 Bytes | R/W | PMnAC4 | Accumulator 4                       |     |     |    |  |
| 77             | 4 Bytes | R/W | PMnAC5 | Accumulator 5                       |     |     |    |  |
| 78             | 4 Bytes | R/W | PMnAC6 | Accumulator 6                       |     |     |    |  |
| 79             | 4 Bytes | R/W | PMnAC7 | Accumulator 7                       |     |     |    |  |
| 80             | 4 Bytes | R/W | PMnAC8 | Accumulator 8                       |     |     |    |  |

---

**Analog Input  
Module Items  
Structure**

**Table 35: Analog Input Module Items Structure**

| First | Decimal | Module Name           |
|-------|---------|-----------------------|
| 04C0H | 1216    | Analog Input Module 1 |
| 04D0H | 1232    | Analog Input Module 2 |
| 04E0H | 1248    | Analog Input Module 3 |
| 04F0H | 1264    | Analog Input Module 4 |
| 0500H | 1280    | Analog Input Module 5 |
| 0510H | 1296    | Analog Input Module 6 |
| 0520H | 1312    | Analog Input Module 7 |
| 0530H | 1328    | Analog Input Module 8 |

Note: TAG AITn is Analog Input Type of Module n.

| RI. | Type    | R/W           | Tag   | Description       |     |     |    |  |                                     |
|-----|---------|---------------|-------|-------------------|-----|-----|----|--|-------------------------------------|
| 00  | 2 Bytes | CNF           | AITn  | Analog Input Type |     |     |    |  |                                     |
| 0   | 0       | 0             | 0     | 0                 | X11 | X10 | X9 |  |                                     |
| X8  | X7      | X6            | X5    | X4                | X3  | X2  | X1 |  |                                     |
|     | X4      | X3            | X2    | X1                |     |     |    | Unit of Measure                        |                                     |
|     |         | = 0000        |       |                   |     |     |    | No Units                               |                                     |
|     |         | = 0001        |       |                   |     |     |    | Celsius                                |                                     |
|     |         | = 0010        |       |                   |     |     |    | Fahrenheit                             |                                     |
|     |         | = 0011        |       |                   |     |     |    | Percent                                |                                     |
|     |         | X5 = 1        |       |                   |     |     |    | Enable Square Root of Input            |                                     |
|     |         | X6 = 1        |       |                   |     |     |    | Alarm on Unfiltered Value              |                                     |
|     |         | X7 = 0        |       |                   |     |     |    | 0...10 Volts                           |                                     |
|     |         | X7 = 1        |       |                   |     |     |    | 0...2 Volts or 0...20 mA or RTD        |                                     |
|     |         | X8 = 1        |       |                   |     |     |    | 20 % Suppression                       |                                     |
|     |         | X11 X10<br>X9 |       |                   |     |     |    | Linearization and Sensor Type          |                                     |
|     |         | = 000         |       |                   |     |     |    | Active Sensor (Linear)                 |                                     |
|     |         | = 001         |       |                   |     |     |    | Nickel 1000 (Johnson Controls)         |                                     |
|     |         | = 010         |       |                   |     |     |    | Nickel 1000 Extended Range             |                                     |
|     |         | = 011         |       |                   |     |     |    | A99 Sensor                             |                                     |
|     |         | = 100         |       |                   |     |     |    | PT1000 Sensor (DIN)                    |                                     |
|     |         | = 101         |       |                   |     |     |    | Nickel 1000 L&G (Version 1.1 or Later) |                                     |
|     |         | = 110         |       |                   |     |     |    | Nickel 1000 DIN (Version 1.1 or Later) |                                     |
|     |         |               |       |                   |     |     |    |  |                                     |
| 01  | Number  | CNF           | HRn   |                   |     |     |    |  | High Range Input                    |
| 02  | Number  | CNF           | LRn   |                   |     |     |    |  | Low Range Input                     |
| 03  | Number  | R/W (E)       | HIA n |                   |     |     |    |  | High Alarm Limit                    |
| 04  | Number  | R/W(E)        | LOA n |                   |     |     |    |  | Low Alarm Limit                     |
| 05  | Number  | CNF           | FTCn  |                   |     |     |    |  | Filter Constant                     |
| 06  | Number  | R/W (E)       | ADF n |                   |     |     |    |  | Differential on Alarm Limit [units] |
| 07  | Number  | R             | AI n  |                   |     |     |    |  | Analog Input Value                  |
| 08  | Number  | R             | AI% n |                   |     |     |    |  | Analog Input Value in % of Range    |
| 09  | 2 Bytes | R             | ADCn  |                   |     |     |    |  | Analog Input in Counts              |
|     |         |               |       |                   |     |     |    |  |                                     |
| 10  | 1 Byte  | R             | AISTn |                   |     |     |    |  | Analog Input Status                 |
| 0   | 0       | 0             | 0     | X4                | X3  | X2  | X1 |  |                                     |
|     |         | X1 = 1        |       |                   |     |     |    | AIHn                                   | High Alarm Condition                |
|     |         | X2 = 1        |       |                   |     |     |    | AILn                                   | Low Alarm Condition                 |
|     |         | X3 = 1        |       |                   |     |     |    | OVRn                                   | Overrange Condition                 |
|     |         | X4 = 1        |       |                   |     |     |    | UNRn                                   | Underrange Condition                |

## Analog Output Module Items Structure

**Table 36: Analog Output Module Items Structure**

| First                        | Decimal | Module Name             |
|------------------------------|---------|-------------------------|
| 0540H                        | 1344    | Analog Output Module 1  |
| 0550H                        | 1360    | Analog Output Module 2  |
| <b>Version 2.0 or Later:</b> |         |                         |
| 0900H                        | 2304    | Analog Output Module 9  |
| 0910H                        | 2320    | Analog Output Module 10 |
| 0920H                        | 2336    | Analog Output Module 11 |
| 0930H                        | 2352    | Analog Output Module 12 |
| 0940H                        | 2368    | Analog Output Module 13 |
| 0950H                        | 2384    | Analog Output Module 14 |

Note: TAG AOTn is Analog Output Type of Module n.

| RI. | Type                               | R/W | Tag   | Description  |
|-----|------------------------------------|-----|-------|--|
| 00  | 1 Byte                             | CNF | AOTn  | Analog Output Type   |
|     | X8   X7   0   0   0   0   X2   X1  |     |       |  |
|     | X2 X1                              |     |       | Output Signal  |
|     | = 00                               |     |       | Output Disabled  |
|     | = 01                               |     |       | Output 0 to 10 V   |
|     | = 10                               |     |       | Output 0 to 20 mA  |
|     | = 11                               |     |       | Output 4 to 20 mA<br>Note: 20 mA outputs not available on<br>Output Modules 11-14. |
|     | X7 = 0                             |     |       | Set Hold at Power Up   |
|     | X7 = 1                             |     |       | Set Auto at Power Up   |
|     | X8 = 1                             |     |       | Enable Hold/Auto Set at Power Up   |
| 01  | Connection                         | CNF | AO@n  | Source of Analog Output Module<br>(analog)   |
| 02  | Connection                         | CNF | AOF@n | Output Forcing Logic Connection  |
| 03  | Number                             | CNF | HROn  | Output High Range  |
| 04  | Number                             | CNF | LROn  | Output Low Range   |
| 05  | Number                             | CNF | OFLn  | Output % Value in Forcing Mode   |
| 06  | Number                             | R/W | OUTn  | Output Module Output Value %   |
| 07  | 1 Byte                             | R/W | AOCn  | Analog Output Control and Status   |
|     | 0   0   X6   0   X4   X3   X2   X1 |     |       |  |
|     | X1 = 1                             | R/W | OUn   | Output in Hold Mode  |
|     | X2 = 1                             | R   | AOHn  | Output at High Limit ... 100%  |
|     | X3 = 1                             | R   | AOLn  | Output at Low Limit ... 0%   |
|     | X4 = 1                             | R   | AOFn  | Output is Forced   |
|     | X6 = 1                             | R   | OULn  | Logic Control Lock<br>(INC@ = 1, DEC@ = 1)   |
| 08  | Number                             | CNF | HLOn  | High Limit on Output %   |
| 09  | Number                             | CNF | LLOn  | Low Limit on Output %  |
| 10  | Connection                         | CNF | INC@n | Source of Increase Signal (logic)  |
| 11  | Connection                         | CNF | DEC@n | Source of Decrease Signal (logic)  |
| 12  | Connection                         | CNF | ENL@n | Enable Limits on Output  |

**Digital Output  
Module Items  
Structure**

**Table 37: Digital Output Module Items Structure**

| First | Decimal | Module Name                   |
|-------|---------|-------------------------------|
| 0560H | 1376    | Digital Output Module 3 (DO3) |
| 0570H | 1392    | Digital Output Module 4 (DO4) |
| 0580H | 1408    | Digital Output Module 5 (DO5) |
| 0590H | 1424    | Digital Output Module 6 (DO6) |
| 05A0H | 1440    | Digital Output Module 7 (DO7) |
| 05B0H | 1456    | Digital Output Module 8 (DO8) |

Note: TAG DOTn is Digital Output Type of Module n.

| RI. | Type        | R/W      | Tag      | Description                                |
|-----|-------------|----------|----------|--|
| 00  | 1 Byte      | CNF      | DOTn     | Digital Output Type                        |
|     | X8 X7 0 0 0 | X3 X2 X1 |          |  |
|     | X3 X2 X1    |          |          | Digital Output Mode                        |
|     | = 000       |          |          | Output Disabled or Paired                  |
|     | = 001       |          |          | On/Off - Logic Source                      |
|     | = 010       |          |          | On/Off - Numeric Source                    |
|     | = 011       |          |          | DAT Output Type                            |
|     | = 100       |          |          | PAT without Feedback                       |
|     | = 101       |          |          | PAT with Feedback                          |
|     | = 110       |          |          | START/STOP                                 |
|     | = 111       |          |          | PULSE TYPE                                 |
|     | X7 = 0      |          |          | Set Hold at Power Up                       |
|     | X7 = 1      |          |          | Set Auto at Power Up                       |
|     | X8 = 1      |          |          | Enable Hold/Auto Set at Power Up           |
| 01  | Connection  | CNF      | DO@n     | Source of DO Module (analog or digital)    |
| 02  | Connection  | CNF      | FB@n     | Source of Feedback Signal                  |
| 03  | Connection  | CNF      | DOF@n    | Output Forcing Logic Connection            |
| 04  | Number      | CNF      | HROn     | Output High Range                          |
| 05  | Number      | CNF      | LROn     | Output Low Range                           |
| 06  | Number      | CNF      | FSTn     | PAT Output Full Stroke Time/DAT Cycle      |
| 07  | Number      | CNF      | DBn      | PAT Deadband/DAT Min. On/Off               |
| 08  | Number      | CNF      | HLOn     | High Limit on Output %                     |
| 09  | Number      | CNF      | LLOn     | Low Limit on Output %                      |
| 10  | Number      | CNF      | OFLn     | Output % Value in Forcing Mode             |
| 11  | Number      | R/W      | OUTn     | Output Module Output Value %               |
| 12  | 1 Byte      | R/W      | DOCn     | Digital Output Control and Status          |
| 0   | 0           | X6 X5 X4 | X3 X2 X1 |  |
|     | X1 = 1      | R/W      | OUHn     | Output in Hold Mode                        |
|     | X2 = 1      | R        | DOHn     | Output at High Limit ... 100%              |
|     | X3 = 1      | R        | DOLn     | Output at Low Limit ... 0%                 |
|     | X4 = 1      | R        | DOF      | Output is Forced                           |
|     | X5 = 1      | R        | AFBn     | Incorrect Feedback                         |
|     | X6 = 1      | R        | OULn     | Logic Control Lock<br>(INC@ = 1, DEC@ = 1) |
| 13  | Connection  | CNF      | INC@n    | Source of Increase Signal (logic)          |
| 14  | Connection  | CNF      | DEC@n    | Source of Decrease Signal (logic)          |
| 15  | Connection  | CNF      | ENL@n    | Enable Limits on Output                    |

**Extension  
Module Items  
Structure**

**Table 38: Extension Module Items Structure**

| First | Decimal | Module Name        |
|-------|---------|--------------------|
| 05C0H | 1472    | Extension Module 1 |
| 0610H | 1552    | Extension Module 2 |
| 0660H | 1632    | Extension Module 3 |
| 06B0H | 1712    | Extension Module 4 |
| 0700H | 1792    | Extension Module 5 |
| 0750H | 1872    | Extension Module 6 |
| 07A0H | 1952    | Extension Module 7 |
| 07F0H | 2032    | Extension Module 8 |

Note: TAG XTnIOMAP is the Extension Module I/O Map of Module n.

| RI.                          | Type   | R/W    | Tag      | Description               |    |    |    |                             |
|------------------------------|--------|--------|----------|---------------------------|----|----|----|-----------------------------|
| 00                           | 1 Byte | CNF    | XTnIOMAP | Extension Module I/O Map  |    |    |    |                             |
| X8                           | X7     | X6     | X5       | X4                        | X3 | X2 | X1 |                             |
|                              |        | X1 = 0 |          |                           |    |    |    | XP1: I/O1 and I/O2 Not Used |
|                              |        | X1 = 1 |          |                           |    |    |    | XP1: I/O1 and I/O2 Used     |
|                              |        | X2 = 0 |          |                           |    |    |    | XP1: I/O3 and I/O4 Not Used |
|                              |        | X2 = 1 |          |                           |    |    |    | XP1: I/O3 and I/O4 Used     |
|                              |        | X3 = 0 |          |                           |    |    |    | XP1: I/O5 and I/O6 Not Used |
|                              |        | X3 = 1 |          |                           |    |    |    | XP1: I/O5 and I/O6 Used     |
|                              |        | X4 = 0 |          |                           |    |    |    | XP1: I/O7 and I/O8 Not Used |
|                              |        | X4 = 1 |          |                           |    |    |    | XP1: I/O7 and I/O8 Used     |
|                              |        | X5 = 0 |          |                           |    |    |    | XP2: I/O1 and I/O2 Not Used |
|                              |        | X5 = 1 |          |                           |    |    |    | XP2: I/O1 and I/O2 Used     |
|                              |        | X6 = 0 |          |                           |    |    |    | XP2: I/O3 and I/O4 Not Used |
|                              |        | X6 = 1 |          |                           |    |    |    | XP2: I/O3 and I/O4 Used     |
|                              |        | X7 = 0 |          |                           |    |    |    | XP2: I/O5 and I/O6 Not Used |
|                              |        | X7 = 1 |          |                           |    |    |    | XP2: I/O5 and I/O6 Used     |
|                              |        | X8 = 0 |          |                           |    |    |    | XP2: I/O7 and I/O8 Not Used |
|                              |        | X8 = 1 |          |                           |    |    |    | XP2: I/O7 and I/O8 Used     |
| 01                           | 1 Byte | CNF    | XTnIOTYP | Extension Module I/O Type |    |    |    |                             |
| 0                            | 0      | 0      | 0        | X4                        | X3 | X2 | X1 |                             |
|                              |        |        |          | X1 = 0                    |    |    |    | XP1: I/O1 and I/O2 Digital  |
|                              |        |        |          | X1 = 1                    |    |    |    | XP1: I/O1 and I/O2 Analog   |
|                              |        |        |          | X2 = 0                    |    |    |    | XP1: I/O3 and I/O4 Digital  |
|                              |        |        |          | X2 = 1                    |    |    |    | XP1: I/O3 and I/O4 Analog   |
|                              |        |        |          | X3 = 0                    |    |    |    | XP1: I/O5 and I/O6 Digital  |
|                              |        |        |          | X3 = 1                    |    |    |    | XP1: I/O5 and I/O6 Analog   |
|                              |        |        |          | X4 = 0                    |    |    |    | XP1: I/O7 and I/O8 Digital  |
|                              |        |        |          | X4 = 1                    |    |    |    | XP1: I/O7 and I/O8 Analog   |
| Continued on next page . . . |        |        |          |                           |    |    |    |                             |

| RI.<br>(Cont.)                      | Type       | R/W    | Tag      | Description   |    |    |    |                           |
|-------------------------------------|------------|--------|----------|---|----|----|----|---------------------------|
| 02                                  | 1 Byte     | CNF    | XTnIOMOD | Extension Module I/O Mode                           |    |    |    |                           |
| X8                                  | X7         | X6     | X5       | X4  | X3 | X2 | X1 |                           |
|                                     |            | X1 = 0 |          |   |    |    |    | XP1: I/O1 and I/O2 Input  |
|                                     |            | X1 = 1 |          |   |    |    |    | XP1: I/O1 and I/O2 Output |
|                                     |            | X2 = 0 |          |   |    |    |    | XP1: I/O3 and I/O4 Input  |
|                                     |            | X2 = 1 |          |   |    |    |    | XP1: I/O3 and I/O4 Output |
|                                     |            | X3 = 0 |          |   |    |    |    | XP1: I/O5 and I/O6 Input  |
|                                     |            | X3 = 1 |          |   |    |    |    | XP1: I/O5 and I/O6 Output |
|                                     |            | X4 = 0 |          |   |    |    |    | XP1: I/O7 and I/O8 Input  |
|                                     |            | X4 = 1 |          |   |    |    |    | XP1: I/O7 and I/O8 Output |
|                                     |            | X5 = 0 |          |   |    |    |    | XP2: I/O1 and I/O2 Input  |
|                                     |            | X5 = 1 |          |   |    |    |    | XP2: I/O1 and I/O2 Output |
|                                     |            | X6 = 0 |          |   |    |    |    | XP2: I/O3 and I/O4 Input  |
|                                     |            | X6 = 1 |          |   |    |    |    | XP2: I/O3 and I/O4 Output |
|                                     |            | X7 = 0 |          |   |    |    |    | XP2: I/O5 and I/O6 Input  |
|                                     |            | X7 = 1 |          |   |    |    |    | XP2: I/O5 and I/O6 Output |
|                                     |            | X8 = 0 |          |   |    |    |    | XP2: I/O7 and I/O8 Input  |
|                                     |            | X8 = 1 |          |   |    |    |    | XP2: I/O7 and I/O8 Output |
| 03                                  | 1 Byte     | CNF    | XTnADX   | Extension Module Address 1 to 255<br>(0 = not used) |    |    |    |                           |
| 04                                  | Connection | CNF    | XTnI1@   | Point Connection - I1                               |    |    |    |                           |
| 05                                  | Connection | CNF    | XTnI2@   | Point Connection - I2                               |    |    |    |                           |
| 06                                  | Connection | CNF    | XTnI3@   | Point Connection - I3                               |    |    |    |                           |
| 07                                  | Connection | CNF    | XTnI4@   | Point Connection - I4                               |    |    |    |                           |
| 08                                  | Connection | CNF    | XTnI5@   | Point Connection - I5                               |    |    |    |                           |
| 09                                  | Connection | CNF    | XTnI6@   | Point Connection - I6                               |    |    |    |                           |
| 10                                  | Connection | CNF    | XTnI7@   | Point Connection - I7                               |    |    |    |                           |
| 11                                  | Connection | CNF    | XTnI8@   | Point Connection - I8                               |    |    |    |                           |
| <b>Continued on next page . . .</b> |            |        |          |   |    |    |    |                           |

| <b>RI.<br/>(Cont.)</b>              | <b>Type</b> | <b>R/W</b> | <b>Tag</b> | <b>Description</b>           |
|-------------------------------------|-------------|------------|------------|------------------------------|
| 12                                  | Number      | CNF        | XTnAHR1    | High Analog Range Point 1    |
| 13                                  | Number      | CNF        | XTnALR1    | Low Analog Range Point 1     |
| 14                                  | Number      | CNF        | XTnAHR2    | High Analog Range Point 2    |
| 15                                  | Number      | CNF        | XTnALR2    | Low Analog Range Point 2     |
| 16                                  | Number      | CNF        | XTnAHR3    | High Analog Range Point 3    |
| 17                                  | Number      | CNF        | XTnALR3    | Low Analog Range Point 3     |
| 18                                  | Number      | CNF        | XTnAHR4    | High Analog Range Point 4    |
| 19                                  | Number      | CNF        | XTnALR4    | Low Analog Range Point 4     |
| 20                                  | Number      | CNF        | XTnAHR5    | High Analog Range Point 5    |
| 21                                  | Number      | CNF        | XTnALR5    | Low Analog Range Point 5     |
| 22                                  | Number      | CNF        | XTnAHR6    | High Analog Range Point 6    |
| 23                                  | Number      | CNF        | XTnALR6    | Low Analog Range Point 6     |
| 24                                  | Number      | CNF        | XTnAHR7    | High Analog Range Point 7    |
| 25                                  | Number      | CNF        | XTnALR7    | Low Analog Range Point 7     |
| 26                                  | Number      | CNF        | XTnAHR8    | High Analog Range Point 8    |
| 27                                  | Number      | CNF        | XTnALR8    | Low Analog Range Point 8     |
| 28                                  | Number      | R/W (E)    | XTnHIA1    | High Alarm Limit Point 1 (*) |
| 29                                  | Number      | R/W (E)    | XTnLOA1    | Low Alarm Limit Point 1 (*)  |
| 30                                  | Number      | R/W (E)    | XTnHIA2    | High Alarm Limit Point 2 (*) |
| 31                                  | Number      | R/W (E)    | XTnLOA2    | Low Alarm Limit Point 2 (*)  |
| 32                                  | Number      | R/W (E)    | XTnHIA3    | High Alarm Limit Point 3 (*) |
| 33                                  | Number      | R/W (E)    | XTnLOA3    | Low Alarm Limit Point 3 (*)  |
| 34                                  | Number      | R/W (E)    | XTnHIA4    | High Alarm Limit Point 4 (*) |
| 35                                  | Number      | R/W (E)    | XTnLOA4    | Low Alarm Limit Point 4 (*)  |
| 36                                  | Number      | R/W (E)    | XTnHIA5    | High Alarm Limit Point 5 (*) |
| 37                                  | Number      | R/W (E)    | XTnLOA5    | Low Alarm Limit Point 5 (*)  |
| 38                                  | Number      | R/W (E)    | XTnHIA6    | High Alarm Limit Point 6 (*) |
| 39                                  | Number      | R/W (E)    | XTnLOA6    | Low Alarm Limit Point 6 (*)  |
| 40                                  | Number      | R/W (E)    | XTnHIA7    | High Alarm Limit Point 7 (*) |
| 41                                  | Number      | R/W (E)    | XTnLOA7    | Low Alarm Limit Point 7 (*)  |
| 42                                  | Number      | R/W (E)    | XTnHIA8    | High Alarm Limit Point 8 (*) |
| 43                                  | Number      | R/W (E)    | XTnLOA8    | Low Alarm Limit Point 8 (*)  |
| <b>Continued on next page . . .</b> |             |            |            |                              |



| RI.<br>(Cont.)                      |     | Type    |     | R/W |     | Tag     |    | Description                          |  |
|-------------------------------------|-----|---------|-----|-----|-----|---------|----|--------------------------------------|--|
| 44                                  |     | 2 Bytes |     | R   |     | XTnAIS  |    | Extension Module Analog Input Status |  |
| X16                                 | X15 | X14     | X13 | X12 | X11 | X10     | X9 |                                      |  |
| X8                                  | X7  | X6      | X5  | X4  | X3  | X2      | X1 |                                      |  |
|                                     |     | X1 = 1  |     |     |     | XTnAIH1 |    | High Alarm Status Point 1            |  |
|                                     |     | X2 = 1  |     |     |     | XTnAIL1 |    | Low Alarm Status Point 1             |  |
|                                     |     | X3 = 1  |     |     |     | XTnAIH2 |    | High Alarm Status Point 2            |  |
|                                     |     | X4 = 1  |     |     |     | XTnAIL2 |    | Low Alarm Status Point 2             |  |
|                                     |     | X5 = 1  |     |     |     | XTnAIH3 |    | High Alarm Status Point 3            |  |
|                                     |     | X6 = 1  |     |     |     | XTnAIL3 |    | Low Alarm Status Point 3             |  |
|                                     |     | X7 = 1  |     |     |     | XTnAIH4 |    | High Alarm Status Point 4            |  |
|                                     |     | X8 = 1  |     |     |     | XTnAIL4 |    | Low Alarm Status Point 4             |  |
|                                     |     | X9 = 1  |     |     |     | XTnAIH5 |    | High Alarm Status Point 5            |  |
|                                     |     | X10 = 1 |     |     |     | XTnAIL5 |    | Low Alarm Status Point 5             |  |
|                                     |     | X11 = 1 |     |     |     | XTnAIH6 |    | High Alarm Status Point 6            |  |
|                                     |     | X12 = 1 |     |     |     | XTnAIL6 |    | Low Alarm Status Point 6             |  |
|                                     |     | X13 = 1 |     |     |     | XTnAIH7 |    | High Alarm Status Point 7            |  |
|                                     |     | X14 = 1 |     |     |     | XTnAIL7 |    | Low Alarm Status Point 7             |  |
|                                     |     | X15 = 1 |     |     |     | XTnAIH8 |    | High Alarm Status Point 8            |  |
|                                     |     | X16 = 1 |     |     |     | XTnAIL8 |    | Low Alarm Status Point 8             |  |
| 45                                  |     | Number  |     | R   |     | XTnAI1  |    | Analog Input Value 1                 |  |
| 46                                  |     | Number  |     | R   |     | XTnAI2  |    | Analog Input Value 2                 |  |
| 47                                  |     | Number  |     | R   |     | XTnAI3  |    | Analog Input Value 3                 |  |
| 48                                  |     | Number  |     | R   |     | XTnAI4  |    | Analog Input Value 4                 |  |
| 49                                  |     | Number  |     | R   |     | XTnAI5  |    | Analog Input Value 5                 |  |
| 50                                  |     | Number  |     | R   |     | XTnAI6  |    | Analog Input Value 6                 |  |
| 51                                  |     | Number  |     | R   |     | XTnAI7  |    | Analog Input Value 7                 |  |
| 52                                  |     | Number  |     | R   |     | XTnAI8  |    | Analog Input Value 8                 |  |
| 53                                  |     | Number  |     | R/W |     | XTnAO1  |    | Analog Output Value Point 1 (*)      |  |
| 54                                  |     | Number  |     | R/W |     | XTnAO2  |    | Analog Output Value Point 2 (*)      |  |
| 55                                  |     | Number  |     | R/W |     | XTnAO3  |    | Analog Output Value Point 3 (*)      |  |
| 56                                  |     | Number  |     | R/W |     | XTnAO4  |    | Analog Output Value Point 4 (*)      |  |
| 57                                  |     | Number  |     | R/W |     | XTnAO5  |    | Analog Output Value Point 5 (*)      |  |
| 58                                  |     | Number  |     | R/W |     | XTnAO6  |    | Analog Output Value Point 6 (*)      |  |
| 59                                  |     | Number  |     | R/W |     | XTnAO7  |    | Analog Output Value Point 7 (*)      |  |
| 60                                  |     | Number  |     | R/W |     | XTnAO8  |    | Analog Output Value Point 8 (*)      |  |
| <b>Continued on next page . . .</b> |     |         |     |     |     |         |    |                                      |  |

| RI.<br>(Cont.)                      | Type    | R/W    | Tag     | Description                           |    |    |    |         |                  |
|-------------------------------------|---------|--------|---------|---------------------------------------|----|----|----|---------|------------------|
| 61                                  | 4 Bytes | R/W    | XTnCNT1 | Digital Input 1 Pulse Count (*)       |    |    |    |         |                  |
| 62                                  | 4 Bytes | R/W    | XTnCNT2 | Digital Input 2 Pulse Count (*)       |    |    |    |         |                  |
| 63                                  | 4 Bytes | R/W    | XTnCNT3 | Digital Input 3 Pulse Count (*)       |    |    |    |         |                  |
| 64                                  | 4 Bytes | R/W    | XTnCNT4 | Digital Input 4 Pulse Count (*)       |    |    |    |         |                  |
| 65                                  | 4 Bytes | R/W    | XTnCNT5 | Digital Input 5 Pulse Count (*)       |    |    |    |         |                  |
| 66                                  | 4 Bytes | R/W    | XTnCNT6 | Digital Input 6 Pulse Count (*)       |    |    |    |         |                  |
| 67                                  | 4 Bytes | R/W    | XTnCNT7 | Digital Input 7 Pulse Count (*)       |    |    |    |         |                  |
| 68                                  | 4 Bytes | R/W    | XTnCNT8 | Digital Input 8 Pulse Count (*)       |    |    |    |         |                  |
| 69                                  | 1 Byte  | R/W    | XTnHDC  | Extension Module Hold Control         |    |    |    |         |                  |
| X8                                  | X7      | X6     | X5      | X4                                    | X3 | X2 | X1 |         |                  |
|                                     |         | X1 = 1 |         |                                       |    |    |    | XTnOUH1 | Output 1 in Hold |
|                                     |         | X2 = 1 |         |                                       |    |    |    | XTnOUH2 | Output 2 in Hold |
|                                     |         | X3 = 1 |         |                                       |    |    |    | XTnOUH3 | Output 3 in Hold |
|                                     |         | X4 = 1 |         |                                       |    |    |    | XTnOUH4 | Output 4 in Hold |
|                                     |         | X5 = 1 |         |                                       |    |    |    | XTnOUH5 | Output 5 in Hold |
|                                     |         | X6 = 1 |         |                                       |    |    |    | XTnOUH6 | Output 6 in Hold |
|                                     |         | X7 = 1 |         |                                       |    |    |    | XTnOUH7 | Output 7 in Hold |
|                                     |         | X8 = 1 |         |                                       |    |    |    | XTnOUH8 | Output 8 in Hold |
|                                     |         |        |         |                                       |    |    |    |         |                  |
| 70                                  | 1 Byte  | R/W    | XTnDO   | Digital Output Control and Status (*) |    |    |    |         |                  |
| X8                                  | X7      | X6     | X5      | X4                                    | X3 | X2 | X1 |         |                  |
|                                     |         | X1 = 1 |         |                                       |    |    |    | XTnDO1  | DO 1 is On       |
|                                     |         | X2 = 1 |         |                                       |    |    |    | XTnDO2  | DO 2 is On       |
|                                     |         | X3 = 1 |         |                                       |    |    |    | XTnDO3  | DO 3 is On       |
|                                     |         | X4 = 1 |         |                                       |    |    |    | XTnDO4  | DO 4 is On       |
|                                     |         | X5 = 1 |         |                                       |    |    |    | XTnDO5  | DO 5 is On       |
|                                     |         | X6 = 1 |         |                                       |    |    |    | XTnDO6  | DO 6 is On       |
|                                     |         | X7 = 1 |         |                                       |    |    |    | XTnDO7  | DO 7 is On       |
|                                     |         | X8 = 1 |         |                                       |    |    |    | XTnDO8  | DO 8 is On       |
| <b>Continued on next page . . .</b> |         |        |         |                                       |    |    |    |         |                  |

| RI.<br>(Cont.)                        | Type   | R/W | Tag     | Description   |
|---------------------------------------|--------|-----|---------|---|
| 71                                    | 1 Byte | R   | XTnDIS  | Digital Input Status  |
| X8   X7   X6   X5   X4   X3   X2   X1 |        |     |         |   |
|                                       | X1 = 1 |     | XTnDI1  | DI 1 is On  |
|                                       | X2 = 1 |     | XTnDI2  | DI 2 is On  |
|                                       | X3 = 1 |     | XTnDI3  | DI 3 is On  |
|                                       | X4 = 1 |     | XTnDI4  | DI 4 is On  |
|                                       | X5 = 1 |     | XTnDI5  | DI 5 is On  |
|                                       | X6 = 1 |     | XTnDI6  | DI 6 is On  |
|                                       | X7 = 1 |     | XTnDI7  | DI 7 is On  |
|                                       | X8 = 1 |     | XTnDI8  | DI 8 is On  |
|                                       |        |     |         |   |
| 72                                    | 1 Byte | R   | XTnST   | Extension Module Local Status   |
| X8   X7   X6   X5   X4   X3   0   X1  |        |     |         |   |
|                                       | X1 = 0 |     | XTnCOM  | Communication Status OK   |
|                                       | X1 = 1 |     | XTnCOM  | Module Not Answering  |
|                                       | X3 = 1 |     | XTnMIS  | XT Databases in DX and XT/XTM do not match.                           |
|                                       | X4 = 1 |     | XTnHARD | XT/XTM Hardware Failure   |
|                                       | X5 = 1 |     | XTnSEL  | XT/XTM Selected on XT Bus   |
|                                       | X6 = 1 |     | XTnERR  | Combined XT/XTM Error<br>X1=1 or X3=1 or X4=1                         |
|                                       | X7 = 0 |     | XTnFAIL | XT/XTM Fail Mode (Set outputs to 0 upon communication failure.)       |
|                                       | X7 = 1 |     | XTnFAIL | XT/XTM Fail Mode (Maintain output status upon communication failure.) |
|                                       | X8 = 1 |     | XTnPWR  | Loss of Power in XT/XTM Module (Momentary Indication)                 |

(\*) If the Item is modified the new value is retransmitted to the extension module.

**Time  
Scheduling  
Items Structure**

**Table 39: Time Scheduling Items Structure**

| First | Decimal | Module Name     |
|-------|---------|-----------------|
| 0840H | 2112    | Time Schedule 1 |
| 0850H | 2128    | Time Schedule 2 |
| 0860H | 2144    | Time Schedule 3 |
| 0870H | 2160    | Time Schedule 4 |
| 0880H | 2176    | Time Schedule 5 |
| 0890H | 2192    | Time Schedule 6 |
| 08A0H | 2208    | Time Schedule 7 |
| 08B0H | 2224    | Time Schedule 8 |

Note: TAG TSnOPT is Time Schedule Options of Schedule n.

| RI. | Type       | R/W     | Tag    | Description                           |
|-----|------------|---------|--------|---------------------------------------|
| 00  | 1 Byte     | CNF     | TSnOPT | Time Schedule Options                 |
| 0   | 0          | 0       | 0      | 0                                     |
|     | X1         |         |        |                                       |
|     | X1 = 0     |         |        | Logic Output Type                     |
|     | X1 = 1     |         |        | Numeric Output Type (not implemented) |
| 01  | Connection | CNF     | TSnEX@ | External Extension Logical Connection |
| 02  | Connection | CNF     | TSnON@ | On Forcing Logical Connection         |
| 03  | Connection | CNF     | TSnOF@ | Off Forcing Logical Connection        |
| 04  | Number     | R/W (E) | TSnXTM | Extension Time (min.)                 |
| 05  | Number     | R       | TSnTIM | Time to Next Event (min.)             |
| 06  | 1 Byte     | R/W     | TSnSTA | Time Schedule Status                  |
| X8  | X7         | X6      | X5     | X4                                    |
|     | X3         | X2      | X1     |                                       |
|     | X1 = 1     | R/W     | TSnHLD | Hold Mode                             |
|     | X2         | R/W     | TSnOUT | Output Status and Control             |
|     | X3 = 1     | R/W     | TSnEXT | Extension Command                     |
|     | X4         | R       | TSnNXO | Next Output                           |
|     | X5 = 1     | R       | TSnEXS | Extension (Keyboard/Serial Link)      |
|     | X6 = 1     | R       | TSnXDI | Extension from DI                     |
|     | X7 = 1     | R       | TSnONF | Forced On Status                      |
|     | X8 = 1     | R       | TSnOFF | Forced Off Status                     |

**Optimal  
Start/Stop  
Items Structure**

**Table 40: Optimal Start/Stop Items Structure**

| First | Decimal | Module Name                 |
|-------|---------|-----------------------------|
| 08C0H | 2240    | Optimal Start/Stop Module 1 |
| 08E0H | 2272    | Optimal Start/Stop Module 2 |

Note: TAG OSnOPT is Module Options of Module n.

| RI.                                 | Type       | R/W | Tag      | Description                                 |
|-------------------------------------|------------|-----|----------|---|
| 00                                  | 1 Byte     | CNF | OSnOPT   | Module Options                              |
| 0                                   | 0          | 0   | 0        | 0   |
|                                     | X1 = 1     |     |          | Heating Mode                                |
|                                     | X2 = 1     |     |          | Cooling Mode                                |
|                                     | X2 = 1x1=1 |     |          | Heating and Cooling Mode                    |
| 01                                  | Connection | CNF | OSnZT@   | Zone Temperature Connection                 |
| 02                                  | Connection | CNF | OSnOT@   | Outdoor Temperature Connection              |
| 03                                  | Connection | CNF | OSnSP@   | Zone Temperature Setpoint Connection        |
| 04                                  | Connection | CNF | OSnOB@   | Off Setpoint Bias Connection                |
| 05                                  | Connection | CNF | OSnDI@   | Disable Module Connection                   |
| 06                                  | Connection | CNF | OSnDA@   | Disable Adaptive Action Connection          |
| 07                                  | Connection | CNF | OSnTS@   | Connection at Time Schedule Output          |
| 08                                  | Connection | CNF | OSnNX@   | Connection at Next Output                   |
| 09                                  | Connection | CNF | OSnTIM@  | Connection at Time to Next Output           |
|                                     |            |     |          |   |
| 10                                  | Number     | CNF | OSnPURGE | Minimum Cool/Heat Time [min]                |
| 11                                  | Number     | CNF | OSnMAXST | Maximum Startup Time [min]                  |
| 12                                  | Number     | CNF | OSnMAXSO | Maximum Optimal Stop Time [min]             |
| 13                                  | Number     | CNF | OSnBHK   | Start Mode Building Factor (Heating)        |
| 14                                  | Number     | CNF | OSnBCK   | Start Mode Building Factor (Cooling)        |
| 15                                  | Number     | CNF | OSnSBHK  | Stop Mode Building Factor (Heating)         |
| 16                                  | Number     | CNF | OSnSBCK  | Stop Mode Building Factor (Cooling)         |
| 17                                  | Number     | CNF | OSnFW    | Percentage Adaptive Control (Filter Weight) |
| 18                                  | Number     | CNF | OSnHTD   | Outdoor Design Temperature (Heating)        |
| 19                                  | Number     | CNF | OSnCTD   | Outdoor Design temperature (Cooling)        |
| 20                                  | Number     | CNF | OSnCRNG  | Control Range                               |
| <b>Continued on next page . . .</b> |            |     |          |   |

| RI.<br>(Cont.) | Type   | R/W | Tag     | Description                     |    |    |    |  |
|----------------|--------|-----|---------|---------------------------------|----|----|----|--|
| 21             | Number | R/W | OSnSP   | Zone Temperature On Setpoint    |    |    |    |  |
| 22             | Number | R/W | OSnOB   | Zone Temperature Stop Mode Bias |    |    |    |  |
| 23             | Number | R   | OSnTIM  | Calculated Optimal Startup Time |    |    |    |  |
| 24             | 1 Byte | R/W | OSnSTA  | Operating Status                |    |    |    |  |
| X8             | X7     | X6  | X5      | X4                              | X3 | X2 | X1 |  |
|                | X1 = 1 | R/W | OSnHLD  | Set Hold Mode                   |    |    |    |  |
|                | X2     | R/W | OSnOUT  | Output Status and Control       |    |    |    |  |
|                | X3 = 1 | R   | OSnHEAT | Operating Mode (1=Heat)         |    |    |    |  |
|                | X4 = 1 | R   | OSnPRE  | Preheating or Precooling        |    |    |    |  |
|                | X5 = 1 | R   | OSnSTO  | Optimal Stop Active             |    |    |    |  |
|                | X6     | R   | OSnIN   | Value of the Command Input      |    |    |    |  |
|                | X7 = 1 | R   | OSnADP  | Adapting Algorithm Disabled     |    |    |    |  |
|                | X8 = 1 | R   | OSnDAS  | Module Disabled                 |    |    |    |  |

---

**Network  
Information  
Module Items  
Structure**

**Table 41: Network Information Module Items Structure**

| First | Decimal | Module Name                |
|-------|---------|----------------------------|
| 0960H | 2400    | Network Information Module |

| RI. | Type        | R/W | Tag   | Description                                 |
|-----|-------------|-----|-------|---|
| 00  | 2 Byte Int. | CNF | NVADX | Network Unit Identifier (DX Address)        |
| 01  | 2 Byte Int  | CNF | NDON  | No. of Network Digital Output Modules (0-8) |
| 02  | 2 Byte Int  | CNF | NAON  | No. of Network Analog Output Modules (0-16) |
| 03  | 2 Byte Int  | CNF | NDIN  | No. of Network Digital Input Modules (0/1)  |
| 04  | 2 Byte Int  | CNF | NAIN  | No. of Network Analog Input Modules (0/1)   |
| 05  | 2 Byte Int  | CNF | NPTN  | No. of Programmable Table Entries           |

**Network Digital  
Output Module  
Items Structure**

**Table 42: Network Digital Output Module Items Structure**

| First | Decimal | Module Name                     |
|-------|---------|---------------------------------|
| 0970H | 2416    | Network Digital Output Module 1 |
| 09A0H | 2464    | Network Digital Output Module 2 |
| 09D0H | 2512    | Network Digital Output Module 3 |
| 0A00H | 2560    | Network Digital Output Module 4 |
| 0A30H | 2608    | Network Digital Output Module 5 |
| 0A60H | 2656    | Network Digital Output Module 6 |
| 0A90H | 2704    | Network Digital Output Module 7 |
| 0AC0H | 2752    | Network Digital Output Module 8 |

Note: TAG NDO<sub>n</sub>-1 is Digital Output 1 of Module n.

| RI.                                 | Type    | R/W | Tag                  | Description                             |
|-------------------------------------|---------|-----|----------------------|---|
| 00                                  | 2 Bytes | R   | NDO <sub>n</sub> CHG | Digital Output Module Change            |
|                                     | X1 = 1  |     |                      | Digital Output Module Connection Change |
| 01                                  | 2 Bytes | R   | NDO <sub>n</sub>     | Digital Output Status                   |
| X16                                 | X X X   | X X | X X                  |   |
| X8                                  | X X X   | X X | X X                  |   |
|                                     | X1 = 1  |     | NDO <sub>n</sub> -1  | Digital Output 1 is On                  |
|                                     | X2 = 1  |     | NDO <sub>n</sub> -2  | Digital Output 2 is On                  |
|                                     | X3 = 1  |     | NDO <sub>n</sub> -3  | Digital Output 3 is On                  |
|                                     | X4 = 1  |     | NDO <sub>n</sub> -4  | Digital Output 4 is On                  |
|                                     | X5 = 1  |     | NDO <sub>n</sub> -5  | Digital Output 5 is On                  |
|                                     | X6 = 1  |     | NDO <sub>n</sub> -6  | Digital Output 6 is On                  |
|                                     | X7 = 1  |     | NDO <sub>n</sub> -7  | Digital Output 7 is On                  |
|                                     | X8 = 1  |     | NDO <sub>n</sub> -8  | Digital Output 8 is On                  |
|                                     | X9 = 1  |     | NDO <sub>n</sub> -9  | Digital Output 9 is On                  |
|                                     | X10 = 1 |     | NDO <sub>n</sub> -10 | Digital Output 10 is On                 |
|                                     | X11 = 1 |     | NDO <sub>n</sub> -11 | Digital Output 11 is On                 |
|                                     | X12 = 1 |     | NDO <sub>n</sub> -12 | Digital Output 12 is On                 |
|                                     | X13 = 1 |     | NDO <sub>n</sub> -13 | Digital Output 13 is On                 |
|                                     | X14 = 1 |     | NDO <sub>n</sub> -14 | Digital Output 14 is On                 |
|                                     | X15 = 1 |     | NDO <sub>n</sub> -15 | Digital Output 15 is On                 |
|                                     | X16 = 1 |     | NDO <sub>n</sub> -16 | Digital Output 16 is On                 |
| <b>Continued on next page . . .</b> |         |     |                      |   |

| RI.<br>(Cont.)                      | Type        | R/W            | Tag      | Description                               |
|-------------------------------------|-------------|----------------|----------|---|
| 02                                  | 2 Bytes     | R              | NDOOnSTA | Digital Output Failure Status             |
| X16                                 | X15 X14 X13 | X12 X11 X10 X9 |          |   |
| X8                                  | X7 X6 X5    | X4 X3 X2 X1    |          |   |
|                                     | X1 = 1      |                |          | Digital Output 1 Failure                  |
|                                     | X2 = 1      |                |          | Digital Output 2 Failure                  |
|                                     | X3 = 1      |                |          | Digital Output 3 Failure                  |
|                                     | X4 = 1      |                |          | Digital Output 4 Failure                  |
|                                     | X5 = 1      |                |          | Digital Output 5 Failure                  |
|                                     | X6 = 1      |                |          | Digital Output 6 Failure                  |
|                                     | X7 = 1      |                |          | Digital Output 7 Failure                  |
|                                     | X8 = 1      |                |          | Digital Output 8 Failure                  |
|                                     | X9 = 1      |                |          | Digital Output 9 Failure                  |
|                                     | X10 = 1     |                |          | Digital Output 10 Failure                 |
|                                     | X11 = 1     |                |          | Digital Output 11 Failure                 |
|                                     | X12 = 1     |                |          | Digital Output 12 Failure                 |
|                                     | X13 = 1     |                |          | Digital Output 13 Failure                 |
|                                     | X14 = 1     |                |          | Digital Output 14 Failure                 |
|                                     | X15 = 1     |                |          | Digital Output 15 Failure                 |
|                                     | X16 = 1     |                |          | Digital Output 16 Failure                 |
| 03                                  | 2 Byte Int  | CNF            | NDOOnTYP | Digital Output Type (= 83 [53 H] if used) |
| 04                                  | Destination | CNF            | NDOOn>1  | Destination Output 1                      |
| 05                                  | Destination | CNF            | NDOOn>2  | Destination Output 2                      |
| 06                                  | Destination | CNF            | NDOOn>3  | Destination Output 3                      |
| 07                                  | Destination | CNF            | NDOOn>4  | Destination Output 4                      |
| 08                                  | Destination | CNF            | NDOOn>5  | Destination Output 5                      |
| 09                                  | Destination | CNF            | NDOOn>6  | Destination Output 6                      |
| 10                                  | Destination | CNF            | NDOOn>7  | Destination Output 7                      |
| 11                                  | Destination | CNF            | NDOOn>8  | Destination Output 8                      |
| 12                                  | Destination | CNF            | NDOOn>9  | Destination Output 9                      |
| 13                                  | Destination | CNF            | NDOOn>10 | Destination Output 10                     |
| 14                                  | Destination | CNF            | NDOOn>11 | Destination Output 11                     |
| 15                                  | Destination | CNF            | NDOOn>12 | Destination Output 12                     |
| 16                                  | Destination | CNF            | NDOOn>13 | Destination Output 13                     |
| 17                                  | Destination | CNF            | NDOOn>14 | Destination Output 14                     |
| 18                                  | Destination | CNF            | NDOOn>15 | Destination Output 15                     |
| 19                                  | Destination | CNF            | NDOOn>16 | Destination Output 16                     |
| <b>Continued on next page . . .</b> |             |                |          |   |



| RI.<br>(Cont.) | Type       | R/W | Tag      | Description         |
|----------------|------------|-----|----------|---------------------|
| 20             | Connection | CNF | NDOn-1@  | Source of Output 1  |
| 21             | Connection | CNF | NDOn-2@  | Source of Output 2  |
| 22             | Connection | CNF | NDOn-3@  | Source of Output 3  |
| 23             | Connection | CNF | NDOn-4@  | Source of Output 4  |
| 24             | Connection | CNF | NDOn-5@  | Source of Output 5  |
| 25             | Connection | CNF | NDOn-6@  | Source of Output 6  |
| 26             | Connection | CNF | NDOn-7@  | Source of Output 7  |
| 27             | Connection | CNF | NDOn-8@  | Source of Output 8  |
| 28             | Connection | CNF | NDOn-9@  | Source of Output 9  |
| 29             | Connection | CNF | NDOn-10@ | Source of Output 10 |
| 30             | Connection | CNF | NDOn-11@ | Source of Output 11 |
| 31             | Connection | CNF | NDOn-12@ | Source of Output 12 |
| 32             | Connection | CNF | NDOn-13@ | Source of Output 13 |
| 33             | Connection | CNF | NDOn-14@ | Source of Output 14 |
| 34             | Connection | CNF | NDOn-15@ | Source of Output 15 |
| 35             | Connection | CNF | NDOn-16@ | Source of Output 16 |

---

**Network  
Analog Output  
Module Items  
Structure**

**Table 43: Network Analog Output Module Items Structure**

| First | Decimal | Module Name                     |
|-------|---------|---------------------------------|
| 0AF0H | 2800    | Network Analog Output Module 1  |
| 0B10H | 2832    | Network Analog Output Module 2  |
| 0B30H | 2864    | Network Analog Output Module 3  |
| 0B50H | 2896    | Network Analog Output Module 4  |
| 0B70H | 2928    | Network Analog Output Module 5  |
| 0B90H | 2960    | Network Analog Output Module 6  |
| 0BB0H | 2992    | Network Analog Output Module 7  |
| 0BD0H | 3024    | Network Analog Output Module 8  |
| 0BF0H | 3056    | Network Analog Output Module 9  |
| 0C10H | 3088    | Network Analog Output Module 10 |
| 0C30H | 3120    | Network Analog Output Module 11 |
| 0C50H | 3152    | Network Analog Output Module 12 |
| 0C70H | 3184    | Network Analog Output Module 13 |
| 0C90H | 3216    | Network Analog Output Module 14 |
| 0CB0H | 3248    | Network Analog Output Module 15 |
| 0CD0H | 3280    | Network Analog Output Module 16 |

Note: TAG NAOonOUT is the value of the Analog Output of Module n.

| RI. | Type        | R/W | Tag     | Description   |     |     |    |                          |
|-----|-------------|-----|---------|---|-----|-----|----|--------------------------|
| 00  | 2 Bytes     | R   | NAOnCHG | Analog Output Module Change                               |     |     |    |                          |
|     | X1 = 1      |     |         | Analog Output Module Connection Change                    |     |     |    |                          |
| 01  | Number      | R   | NAOn    | Analog Output Value                                       |     |     |    |                          |
| 02  | 2 Bytes     | R   | NAOnSTA | Analog Output Failure Status                              |     |     |    |                          |
| X16 | X15         | X14 | X13     | X12   | X11 | X10 | X9 |                          |
| X8  | X7          | X6  | X5      | X4  | X3  | X2  | X1 |                          |
|     | X1 = 1      |     |         |   |     |     |    | Analog Output 1 Failure  |
|     | X2 = 1      |     |         |   |     |     |    | Analog Output 2 Failure  |
|     | X3 = 1      |     |         |   |     |     |    | Analog Output 3 Failure  |
|     | X4 = 1      |     |         |   |     |     |    | Analog Output 4 Failure  |
|     | X5 = 1      |     |         |   |     |     |    | Analog Output 5 Failure  |
|     | X6 = 1      |     |         |   |     |     |    | Analog Output 6 Failure  |
|     | X7 = 1      |     |         |   |     |     |    | Analog Output 7 Failure  |
|     | X8 = 1      |     |         |   |     |     |    | Analog Output 8 Failure  |
|     | X9 = 1      |     |         |   |     |     |    | Analog Output 9 Failure  |
|     | X10 = 1     |     |         |   |     |     |    | Analog Output 10 Failure |
|     | X11 = 1     |     |         |   |     |     |    | Analog Output 11 Failure |
|     | X12 = 1     |     |         |   |     |     |    | Analog Output 12 Failure |
|     | X13 = 1     |     |         |   |     |     |    | Analog Output 13 Failure |
|     | X14 = 1     |     |         |   |     |     |    | Analog Output 14 Failure |
|     | X15 = 1     |     |         |   |     |     |    | Analog Output 15 Failure |
|     | X16 = 1     |     |         |   |     |     |    | Analog Output 16 Failure |
|     |             |     |         |   |     |     |    |                          |
| 03  | Destination | CNF | NAOnDIM | Analog Output Value Dimension (units) (=55 [37H] if used) |     |     |    |                          |
| 04  | Destination | CNF | NAOn>1  | Destination Output 1                                      |     |     |    |                          |
| 05  | Destination | CNF | NAOn>2  | Destination Output 2                                      |     |     |    |                          |
| 06  | Destination | CNF | NAOn>3  | Destination Output 3                                      |     |     |    |                          |
| 07  | Destination | CNF | NAOn>4  | Destination Output 4                                      |     |     |    |                          |
| 08  | Destination | CNF | NAOn>5  | Destination Output 5                                      |     |     |    |                          |
| 09  | Destination | CNF | NAOn>6  | Destination Output 6                                      |     |     |    |                          |
| 10  | Destination | CNF | NAOn>7  | Destination Output 7                                      |     |     |    |                          |
| 11  | Destination | CNF | NAOn>8  | Destination Output 8                                      |     |     |    |                          |
| 12  | Destination | CNF | NAOn>9  | Destination Output 9                                      |     |     |    |                          |
| 13  | Destination | CNF | NAOn>10 | Destination Output 10                                     |     |     |    |                          |
| 14  | Destination | CNF | NAOn>11 | Destination Output 11                                     |     |     |    |                          |
| 15  | Destination | CNF | NAOn>12 | Destination Output 12                                     |     |     |    |                          |
| 16  | Destination | CNF | NAOn>13 | Destination Output 13                                     |     |     |    |                          |
| 17  | Destination | CNF | NAOn>14 | Destination Output 14                                     |     |     |    |                          |
| 18  | Destination | CNF | NAOn>15 | Destination Output 15                                     |     |     |    |                          |
| 19  | Destination | CNF | NAOn>16 | Destination Output 16                                     |     |     |    |                          |
| 20  | Connection  | CNF | NAOn@   | Analog Output Source                                      |     |     |    |                          |

**Network Digital  
Input Module  
Items Structure**

**Table 44: Network Digital Input Module Items Structure**

| First | Decimal | Module Name                  |
|-------|---------|------------------------------|
| 0CF0H | 3312    | Network Digital Input Module |

| RI.                          | Type    | R/W | Tag    | Description                      |     |     |    |                        |                                   |
|------------------------------|---------|-----|--------|----------------------------------|-----|-----|----|------------------------|-----------------------------------|
| 00                           | 2 Bytes | R   | NDICHG | Digital Input Module Change      |     |     |    |                        |                                   |
|                              | X1 = 1  |     |        | Digital Input Module Type Change |     |     |    |                        |                                   |
| 01                           | 2 Bytes | R   | NDI1   | Digital Input Module 1 Status    |     |     |    |                        |                                   |
| X16                          | X15     | X14 | X13    | X12                              | X11 | X10 | X9 |                        |                                   |
| X8                           | X7      | X6  | X5     | X4                               | X3  | X2  | X1 |                        |                                   |
|                              | X1 = 1  |     |        | NDI1-1                           |     |     |    | Digital Input 1 is On  |                                   |
|                              | X2 = 1  |     |        | NDI1-2                           |     |     |    | Digital Input 2 is On  |                                   |
|                              | X3 = 1  |     |        | NDI1-3                           |     |     |    | Digital Input 3 is On  |                                   |
|                              | X4 = 1  |     |        | NDI1-4                           |     |     |    | Digital Input 4 is On  |                                   |
|                              | X5 = 1  |     |        | NDI1-5                           |     |     |    | Digital Input 5 is On  |                                   |
|                              | X6 = 1  |     |        | NDI1-6                           |     |     |    | Digital Input 6 is On  |                                   |
|                              | X7 = 1  |     |        | NDI1-7                           |     |     |    | Digital Input 7 is On  |                                   |
|                              | X8 = 1  |     |        | NDI1-8                           |     |     |    | Digital Input 8 is On  |                                   |
|                              | X9 = 1  |     |        | NDI1-9                           |     |     |    | Digital Input 9 is On  |                                   |
|                              | X10 = 1 |     |        | NDI1-10                          |     |     |    | Digital Input 10 is On |                                   |
|                              | X11 = 1 |     |        | NDI1-11                          |     |     |    | Digital Input 11 is On |                                   |
|                              | X12 = 1 |     |        | NDI1-12                          |     |     |    | Digital Input 12 is On |                                   |
|                              | X13 = 1 |     |        | NDI1-13                          |     |     |    | Digital Input 13 is On |                                   |
|                              | X14 = 1 |     |        | NDI1-14                          |     |     |    | Digital Input 14 is On |                                   |
|                              | X15 = 1 |     |        | NDI1-15                          |     |     |    | Digital Input 15 is On |                                   |
|                              | X16 = 1 |     |        | NDI1-16                          |     |     |    | Digital Input 16 is On |                                   |
| 02                           | 2 Bytes | R   | NDI2   | Digital Input Module 2 Status    |     |     |    |                        |                                   |
| 03                           | 2 Bytes | R   | NDI3   | Digital Input Module 3 Status    |     |     |    |                        |                                   |
| 04                           | 2 Bytes | R   | NDI4   | Digital Input Module 4 Status    |     |     |    |                        |                                   |
| 05                           | 2 Bytes | R   | NDI5   | Digital Input Module 5 Status    |     |     |    |                        |                                   |
| 06                           | 2 Bytes | R   | NDI6   | Digital Input Module 6 Status    |     |     |    |                        |                                   |
| 07                           | 2 Bytes | R   | NDI7   | Digital Input Module 7 Status    |     |     |    |                        |                                   |
| 08                           | 2 Bytes | R   | NDI8   | Digital Input Module 8 Status    |     |     |    |                        |                                   |
| 09                           | 2 Bytes | R   | NDISTA | Digital Input Reliability Status |     |     |    |                        |                                   |
| X16                          | X15     | X14 | X13    | X12                              | X11 | X10 | X9 |                        |                                   |
| X8                           | X7      | X6  | X5     | X4                               | X3  | X2  | X1 |                        |                                   |
|                              | X1 = 1  |     |        |                                  |     |     |    | NDIU1                  | Digital Input Module 1 Unreliable |
|                              | X2 = 1  |     |        |                                  |     |     |    | NDIU2                  | Digital Input Module 2 Unreliable |
|                              | X3 = 1  |     |        |                                  |     |     |    | NDIU3                  | Digital Input Module 3 Unreliable |
|                              | X4 = 1  |     |        |                                  |     |     |    | NDIU4                  | Digital Input Module 4 Unreliable |
|                              | X5 = 1  |     |        |                                  |     |     |    | NDIU5                  | Digital Input Module 5 Unreliable |
|                              | X6 = 1  |     |        |                                  |     |     |    | NDIU6                  | Digital Input Module 6 Unreliable |
|                              | X7 = 1  |     |        |                                  |     |     |    | NDIU7                  | Digital Input Module 7 Unreliable |
| Continued on next page . . . |         |     |        |                                  |     |     |    |                        |                                   |

| RI.<br>(Cont.) | Type          | R/W | Tag     | Description                                     |
|----------------|---------------|-----|---------|---|
|                | X8 = 1        |     | NDIU8   | Digital Input Module 8 Unreliable               |
| 10             | 2 Byte<br>Int | CNF | NDI1TYP | Digital Input Module 1 Type (=83 [53H] if used) |
| 11             | 2 Byte<br>Int | CNF | NDI2TYP | Digital Input Module 2 Type (=83 [53H] if used) |
| 12             | 2 Byte<br>Int | CNF | NDI3TYP | Digital Input Module 3 Type (=83 [53H] if used) |
| 13             | 2 Byte<br>Int | CNF | NDI4TYP | Digital Input Module 4 Type (=83 [53H] if used) |
| 14             | 2 Byte<br>Int | CNF | NDI5TYP | Digital Input Module 5 Type (=83 [53H] if used) |
| 15             | 2 Byte<br>Int | CNF | NDI6TYP | Digital Input Module 6 Type (=83 [53H] if used) |
| 16             | 2 Byte<br>Int | CNF | NDI7TYP | Digital Input Module 7 Type (=83 [53H] if used) |
| 17             | 2 Byte<br>Int | CNF | NDI8TYP | Digital Input Module 8 Type (=83 [53H] if used) |

---

**Network  
Analog Input  
Module Items  
Structure**

**Table 45: Network Analog Input Module Items Structure**

| First | Decimal | Module Name                 |
|-------|---------|-----------------------------|
| 0D10H | 3344    | Network Analog Input Module |

| RI.                                 | Type    | R/W | Tag     | Description                          |
|-------------------------------------|---------|-----|---------|--------------------------------------|
| 00                                  | 2 Bytes | R   | NAICHNG | Analog Input Module Change           |
|                                     | X1 = 1  |     |         | Analog Input Module Dimension Change |
| 01                                  | Number  | R   | NAI1    | Analog Input 1 Value                 |
| 02                                  | Number  | R   | NAI2    | Analog Input 2 Value                 |
| 03                                  | Number  | R   | NAI3    | Analog Input 3 Value                 |
| 04                                  | Number  | R   | NAI4    | Analog Input 4 Value                 |
| 05                                  | Number  | R   | NAI5    | Analog Input 5 Value                 |
| 06                                  | Number  | R   | NAI6    | Analog Input 6 Value                 |
| 07                                  | Number  | R   | NAI7    | Analog Input 7 Value                 |
| 08                                  | Number  | R   | NAI8    | Analog Input 8 Value                 |
| 09                                  | Number  | R   | NAI9    | Analog Input 9 Value                 |
| 10                                  | Number  | R   | NAI10   | Analog Input 10 Value                |
| 11                                  | Number  | R   | NAI11   | Analog Input 11 Value                |
| 12                                  | Number  | R   | NAI12   | Analog Input 12 Value                |
| 13                                  | Number  | R   | NAI13   | Analog Input 13 Value                |
| 14                                  | Number  | R   | NAI14   | Analog Input 14 Value                |
| 15                                  | Number  | R   | NAI15   | Analog Input 15 Value                |
| 16                                  | Number  | R   | NAI16   | Analog Input 16 Value                |
| <b>Continued on next page . . .</b> |         |     |         |                                      |

| RI.<br>(Cont.) | Type       | R/W | Tag      | Description  |     |     |    |  |                            |
|----------------|------------|-----|----------|--|-----|-----|----|--|----------------------------|
| 17             | 2 Bytes    | R   | NAISTA   | Analog Input Reliability Status                        |     |     |    |  |                            |
| X16            | X15        | X14 | X13      | X12  | X11 | X10 | X9 |  |                            |
| X8             | X7         | X6  | X5       | X4   | X3  | X2  | X1 |  |                            |
|                | X1 = 1     |     |          | NAIU1  |     |     |    |  | Analog Input 1 Unreliable  |
|                | X2 = 1     |     |          | NAIU2  |     |     |    |  | Analog Input 2 Unreliable  |
|                | X3 = 1     |     |          | NAIU3  |     |     |    |  | Analog Input 3 Unreliable  |
|                | X4 = 1     |     |          | NAIU4  |     |     |    |  | Analog Input 4 Unreliable  |
|                | X5 = 1     |     |          | NAIU5  |     |     |    |  | Analog Input 5 Unreliable  |
|                | X6 = 1     |     |          | NAIU6  |     |     |    |  | Analog Input 6 Unreliable  |
|                | X7 = 1     |     |          | NAIU7  |     |     |    |  | Analog Input 7 Unreliable  |
|                | X8 = 1     |     |          | NAIU8  |     |     |    |  | Analog Input 8 Unreliable  |
|                | X9 = 1     |     |          | NAIU9  |     |     |    |  | Analog Input 9 Unreliable  |
|                | X10 = 1    |     |          | NAIU10   |     |     |    |  | Analog Input 10 Unreliable |
|                | X11 = 1    |     |          | NAIU11   |     |     |    |  | Analog Input 11 Unreliable |
|                | X12 = 1    |     |          | NAIU12   |     |     |    |  | Analog Input 12 Unreliable |
|                | X13 = 1    |     |          | NAIU13   |     |     |    |  | Analog Input 13 Unreliable |
|                | X14 = 1    |     |          | NAIU14   |     |     |    |  | Analog Input 14 Unreliable |
|                | X15 = 1    |     |          | NAIU15   |     |     |    |  | Analog Input 15 Unreliable |
|                | X16 = 1    |     |          | NAIU16   |     |     |    |  | Analog Input 16 Unreliable |
| 18             | 2 Byte Int | CNF | NAI1DIM  | Analog Input 1 Value Dimension<br>(=55 [37H] if used)  |     |     |    |  |                            |
| 19             | 2 Byte Int | CNF | NAI2DIM  | Analog Input 2 Value Dimension<br>(=55 [37H] if used)  |     |     |    |  |                            |
| 20             | 2 Byte Int | CNF | NAI3DIM  | Analog Input 3 Value Dimension<br>(=55 [37H] if used)  |     |     |    |  |                            |
| 21             | 2 Byte Int | CNF | NAI4DIM  | Analog Input 4 Value Dimension<br>(=55 [37H] if used)  |     |     |    |  |                            |
| 22             | 2 Byte Int | CNF | NAI5DIM  | Analog Input 5 Value Dimension<br>(=55 [37H] if used)  |     |     |    |  |                            |
| 23             | 2 Byte Int | CNF | NAI6DIM  | Analog Input 6 Value Dimension<br>(=55 [37H] if used)  |     |     |    |  |                            |
| 24             | 2 Byte Int | CNF | NAI7DIM  | Analog Input 7 Value Dimension<br>(=55 [37H] if used)  |     |     |    |  |                            |
| 25             | 2 Byte Int | CNF | NAI8DIM  | Analog Input 8 Value Dimension<br>(=55 [37H] if used)  |     |     |    |  |                            |
| 26             | 2 Byte Int | CNF | NAI9DIM  | Analog Input 9 Value Dimension<br>(=55 [37H] if used)  |     |     |    |  |                            |
| 27             | 2 Byte Int | CNF | NAI10DIM | Analog Input 10 Value Dimension<br>(=55 [37H] if used) |     |     |    |  |                            |
| 28             | 2 Byte Int | CNF | NAI11DIM | Analog Input 11 Value Dimension<br>(=55 [37H] if used) |     |     |    |  |                            |
| 29             | 2 Byte Int | CNF | NAI12DIM | Analog Input 12 Value Dimension<br>(=55 [37H] if used) |     |     |    |  |                            |
| 30             | 2 Byte Int | CNF | NAI13DIM | Analog Input 13 Value Dimension<br>(=55 [37H] if used) |     |     |    |  |                            |
| 31             | 2 Byte Int | CNF | NAI14DIM | Analog Input 14 Value Dimension<br>(=55 [37H] if used) |     |     |    |  |                            |
| 32             | 2 Byte Int | CNF | NAI15DIM | Analog Input 15 Value Dimension<br>(=55 [37H] if used) |     |     |    |  |                            |
| 33             | 2 Byte Int | CNF | NAI16DIM | Analog Input 16 Value Dimension<br>(=55 [37H] if used) |     |     |    |  |                            |



# Appendix C: Programmable Function Module Items

## Algorithm 1 - PID Controller

**Table 46: Algorithm 1 - PID Controller**

| RI.                          | PM Tag | Alg. Tag | Description  |
|------------------------------|--------|----------|--|
| 00                           | PMnTYP | TYP      | Algorithm Type = 01  |
| 01                           | PMnOPT | OPT      | Controller Options   |
|                              |        |          | 0 0 0 0 0 0 0 X  |
|                              |        |          | X8 X7 0 X5 0 X3 0 X  |
|                              |        | SOFE     | X1 = 1 Enable Shutoff Mode                                 |
|                              |        | STAE     | X3 = 1 Enable Startup Mode                                 |
|                              |        | SYME     | X5 = 1 Enable Symmetric Mode                               |
|                              |        | PIDP     | X7 = 1 Enable PID to P Change                              |
|                              |        | REM      | X8 = 1 Remote Mode   |
|                              |        | SOTO     | X9 = 1 Enable Shutoff to Off Change                        |
| 10                           | PMn1@  | PV@      | Process Variable Connection                                |
| 11                           | PMn2@  | RS@      | Remote Setpoint Connection                                 |
| 12                           | PMn3@  | RV@      | Reference Variable Connection                              |
| 13                           | PMn4@  | PB@      | Proportional Band Connection                               |
| 14                           | PMn5@  | OF@      | Off Mode Logic Control Connection                          |
| 15                           | PMn6@  | SB@      | Standby Mode Logic Control Connection                      |
| 16                           | PMn7@  | RA@      | Reverse Acting Logic Control Connection                    |
| 17                           | PMn8@  | EF@      | External Forcing Logic Control Connection                  |
| 20                           | PMn11@ | OB@      | Output Bias Connection                                     |
| 22                           | PMn13@ | MNWS@    | Minimum Working Setpoint Connection (Version 1.1 or Later) |
| 23                           | PMn14@ | MXWS@    | Maximum Working Setpoint Connection (Version 1.1 or Later) |
| 26                           | PMnK1  | LSP      | Local Setpoint   |
| 27                           | PMnK2  | PB       | Proportional Band  |
| 28                           | PMnK3  | TI       | Reset Action   |
| 29                           | PMnK4  | TD       | Rate Action  |
| 30                           | PMnK5  | BSB      | Change of Setpoint During Standby                          |
| 31                           | PMnK6  | BOF      | Change of Setpoint During Off                              |
| 32                           | PMnK7  | SBC      | Symmetry Band  |
| 33                           | PMnK8  | EDB      | Error Deadband   |
| 34                           | PMnK9  | OB       | Output Bias  |
| 35                           | PMnK10 | MNWS     | Minimum Working Setpoint (Version 1.1 or Later)            |
| 36                           | PMnK11 | HIL      | Upper Limit of the Control Output                          |
| 37                           | PMnK12 | LOL      | Lower Limit of the Control Output                          |
| 38                           | PMnK13 | DHH      | Deviation High High Alarm Value                            |
| 39                           | PMnK14 | DH       | Deviation High Alarm Value                                 |
| Continued on next page . . . |        |          |  |

| RI.<br>(Cont.) | PM Tag | Alg. Tag | Description                                     |
|----------------|--------|----------|---|
| 40             | PMnK15 | DL       | Deviation Low Alarm Value                       |
| 41             | PMnK16 | DLL      | Deviation Low Low Alarm Value                   |
| 42             | PMnK17 | MXWS     | Maximum Working Setpoint (Version 1.1 or Later) |
| 51             | PMnK26 | SOL      | Shutoff Output Level                            |
| 52             | PMnK27 | STL      | Startup Output Level                            |
| 59             | PMnK34 | EFL      | External Force Output Level                     |
| 60             | PMnOU1 | OCM      | Control Output                                  |
| 61             | PMnOU2 | WSP      | Working Setpoint                                |
| 63             | PMnOU4 | PV       | Actual Process Variable                         |
| 64             | PMnOU5 | PVS      | PV Gain (100/Span)                              |
| 65             | PMnOU6 | PVL      | PV Low Range                                    |
| 66             | PMnOU7 | RSP      | Actual Remote Setpoint                          |
| 67             | PMnOU8 | RV       | Actual Reference Variable                       |
|                |        |          |   |
| 70             | PMnHDC |          | Hold Mode Control/Status                        |
|                |        |          | 0   0   0   0   0   0   X2   X                  |
|                |        | HLD      | X1 = 1   Hold Control/Status                    |
|                |        | CMP      | X2 = 1   Computer Mode Request                  |
|                |        |          |   |
| 72             | PMnST  |          | Controller Status                               |
|                |        |          | 0   X1   X1   X1   X1   X1   X1   X             |
|                |        |          | X8   X7   X6   X5   X4   X3   X2   X            |
|                |        | CML      | X1 = 1   Controller Output at Low Limit         |
|                |        | CMH      | X2 = 1   Controller Output at High Limit        |
|                |        | FORC     | X3 = 1   Force-Back to OCM Active               |
|                |        | LLDA     | X5 = 1   Deviation Alarm Low Low                |
|                |        | LDA      | X6 = 1   Deviation Alarm Low                    |
|                |        | HDA      | X7 = 1   Deviation Alarm High                   |
|                |        | HHDA     | X8 = 1   Deviation Alarm High High              |
|                |        | SOF      | X9 = 1   Shutoff Mode Active                    |
|                |        | STA      | X10 = 1   Startup Mode Active                   |
|                |        | EF       | X11 = 1   External Forcing Active               |
|                |        | OF       | X12 = 1   Off Mode Active                       |
|                |        | SB       | X13 = 1   Standby Mode Active                   |
|                |        | RA       | X14 = 1   Reverse Action Mode                   |
|                |        | HEAT     | X15 = 1   Heating Mode (RA) or PV Below         |
|                |        |          | Symmetrical Band Center                         |



**Algorithm 2 -  
On/Off  
Controller**

**Table 47: Algorithm 2 - On/Off Controller**

| RI.                                 | PM Tag | Alg. Tag | Description  |
|-------------------------------------|--------|----------|--|
| 00                                  | PMnTYP | TYP      | Algorithm Type = 02  |
| 01                                  | PMnOPT | OPT      | Controller Options   |
|                                     |        |          | 0 0 0 0 0 0 0 0  |
|                                     |        |          | X8 0 X6 X5 X4 X3 X2 X1                                     |
|                                     |        | SOFE     | X1 = 1 Enable Shutoff Mode                                 |
|                                     |        | SOFL     | X2 = 0 Shutoff Out Level = 0                               |
|                                     |        | SOFL     | X2 = 1 Shutoff Out Level = 1                               |
|                                     |        | STAE     | X3 = 1 Enable Startup Mode                                 |
|                                     |        | STAL     | X4 = 0 Startup Out Level = 0                               |
|                                     |        | STAL     | X4 = 1 Startup Out Level = 1                               |
|                                     |        | SYME     | X5 = 1 Enable Symmetric Mode                               |
|                                     |        | EFL      | X6 = 0 External Forcing Out Level = 0                      |
|                                     |        | EFL      | X6 = 1 External Forcing Out Level = 1                      |
|                                     |        | REM      | X8 = 1 Remote Mode   |
| 10                                  | PMn1@  | PV@      | Process Variable Connection                                |
| 11                                  | PMn2@  | RS@      | Remote Setpoint Connection                                 |
| 12                                  | PMn3@  | RV@      | Reference Variable Connection                              |
| 14                                  | PMn5@  | OF@      | Off Mode Logic Control Connection                          |
| 15                                  | PMn6@  | SB@      | Standby Mode Logic Control Connection                      |
| 16                                  | PMn7@  | RA@      | Reverse Acting Logic Control Connection                    |
| 17                                  | PMn8@  | EF@      | External Forcing Logic Control Connection                  |
| 22                                  | PMn13@ | MNWS@    | Minimum Working Setpoint Connection (Version 1.1 or Later) |
| 23                                  | PMn14@ | MXWS@    | Maximum Working Setpoint Connection (Version 1.1 or Later) |
| 26                                  | PMnK1  | LSP      | Local Setpoint   |
| 27                                  | PMnK2  | ACT      | Action Mode  |
| 28                                  | PMnK3  | DIF      | Differential   |
| 30                                  | PMnK5  | BSB      | Change of Setpoint During Standby                          |
| 31                                  | PMnK6  | BOF      | Change of Setpoint During Off                              |
| 32                                  | PMnK7  | SBC      | Symmetry Band  |
| 35                                  | PMnK10 | MNWS     | Minimum Working Setpoint (Version 1.1 or Later)            |
| 38                                  | PMnK13 | DHH      | Deviation High High Alarm Value                            |
| 39                                  | PMnK14 | DH       | Deviation High Alarm Value                                 |
| 40                                  | PMnK15 | DL       | Deviation Low Alarm Value                                  |
| 41                                  | PMnK16 | DLL      | Deviation Low Low Alarm Value                              |
| 42                                  | PMnK17 | MXWS     | Maximum Working Setpoint (Version 1.1 or Later)            |
| <b>Continued on next page . . .</b> |        |          |  |

| RI.<br>(Cont.) | PM Tag | Alg.<br>Tag | Description                      |     |                           |     |     |     |     |    |  |  |
|----------------|--------|-------------|----------------------------------|-----|---------------------------|-----|-----|-----|-----|----|--|--|
| 61             | PMnOU2 | WSP         | Working Setpoint                 |     |                           |     |     |     |     |    |  |  |
| 63             | PMnOU4 | PV          | Actual Process Variable          |     |                           |     |     |     |     |    |  |  |
| 64             | PMnOU5 | PVS         | PV Gain (100/Span)               |     |                           |     |     |     |     |    |  |  |
| 65             | PMnOU6 | PVL         | PV Low Range                     |     |                           |     |     |     |     |    |  |  |
| 66             | PMnOU7 | RSP         | Actual Remote Setpoint           |     |                           |     |     |     |     |    |  |  |
| 67             | PMnOU8 | RV          | Actual Reference Variable        |     |                           |     |     |     |     |    |  |  |
|                |        |             | 0                                | 0   | 0                         | 0   | 0   | 0   | X2  | X1 |  |  |
|                |        | HLD         | X1 = 1                           |     | Hold Control/Status       |     |     |     |     |    |  |  |
|                |        | CMP         | X2 = 1                           |     | Computer Mode Request     |     |     |     |     |    |  |  |
| 71             | PMnDO  |             | Logic Outputs Control and Status |     |                           |     |     |     |     |    |  |  |
|                |        |             | 0                                | 0   | 0                         | 0   | 0   | 0   | 0   | X1 |  |  |
|                |        | OCM         | X1                               |     | Control Output            |     |     |     |     |    |  |  |
| 72             | PMnST  |             | Controller Status                |     |                           |     |     |     |     |    |  |  |
|                |        |             | 0                                | X15 | X14                       | X13 | X12 | X11 | X10 | X9 |  |  |
|                |        |             | X8                               | X7  | X6                        | X5  | 0   | 0   | X2  | X1 |  |  |
|                |        | LLDA        | X5 = 1                           |     | Deviation Alarm Low Low   |     |     |     |     |    |  |  |
|                |        | LDA         | X6 = 1                           |     | Deviation Alarm Low       |     |     |     |     |    |  |  |
|                |        | HDA         | X7 = 1                           |     | Deviation Alarm High      |     |     |     |     |    |  |  |
|                |        | HHDA        | X8 = 1                           |     | Deviation Alarm High High |     |     |     |     |    |  |  |
|                |        | SOF         | X9 = 1                           |     | Shutoff Mode Active       |     |     |     |     |    |  |  |
|                |        | STA         | X10 = 1                          |     | Startup Mode Active       |     |     |     |     |    |  |  |
|                |        | EF          | X11 = 1                          |     | External Forcing Active   |     |     |     |     |    |  |  |
|                |        | OF          | X12 = 1                          |     | Off Mode Active           |     |     |     |     |    |  |  |
|                |        | SB          | X13 = 1                          |     | Standby Mode Active       |     |     |     |     |    |  |  |
|                |        | RA          | X14 = 1                          |     | Reverse Action Mode       |     |     |     |     |    |  |  |
|                |        | HEAT        | X15 = 1                          |     | Heating Mode (RA) or      |     |     |     |     |    |  |  |
|                |        |             | PV Below Symmetrical Band Center |     |                           |     |     |     |     |    |  |  |

**Algorithm 3 -  
Heating/Cooling  
PID Controller**

**Table 48: Algorithm 3 - Heating/Cooling PID Controller**

| RI.                                 | PM Tag | Alg. Tag | Description   |
|-------------------------------------|--------|----------|---|
| 00                                  | PMnTYP | TYP      | Algorithm Type = 03   |
| 01                                  | PMnOPT | OPT      | Controller Options  |
|                                     |        |          | 0 0 0 0 0 0 0 X9  |
|                                     |        |          | X8 X7 0 0 0 X3 0 X1   |
|                                     |        | SOFE     | X1 = 1 Enable Shutoff Mode  |
|                                     |        | STAE     | X3 = 1 Enable Startup Mode  |
|                                     |        | PIDP     | X7 = 1 Enable PID to P Change   |
|                                     |        | REM      | X8 = 1 Remote Mode  |
|                                     |        | SOTO     | X9 = 1 Enable Shutoff to Off Change                                     |
|                                     |        | EZCO     | X10 = 1 Enable Zero Output Changeover (Versions 1.4, 2.3, 3.3 or Later) |
| 10                                  | PMn1@  | PV@      | Process Variable Connection   |
| 11                                  | PMn2@  | RS1@     | Remote Setpoint Connection  |
| 12                                  | PMn3@  | RV1@     | Reference Variable Connection   |
| 13                                  | PMn4@  | PB@      | Proportional Band Connection  |
| 14                                  | PMn5@  | OF@      | Off Mode Logic Control Connection                                       |
| 15                                  | PMn6@  | SB@      | Standby Mode Logic Control Connection                                   |
| 16                                  | PMn7@  | RA@      | Reverse Acting Logic Control Connection                                 |
| 17                                  | PMn8@  | EF@      | External Forcing Logic Control Connection                               |
| 18                                  | PMn9@  | RS2@     | Second Loop Remote Setpoint Connection                                  |
| 19                                  | PMn10@ | RV2@     | Second Loop Reference Variable Connection                               |
| 20                                  | PMn11@ | OB1@     | Output Bias Connection  |
| 21                                  | PMn12@ | OB2@     | Second Loop Output Bias Connection                                      |
| 22                                  | PMn13@ | MNWS@    | Minimum Working Setpoint Connection (Version 1.1 or Later)              |
| 23                                  | PMn14@ | MXWS@    | Maximum Working Setpoint Connection (Version 1.1 or Later)              |
| 26                                  | PMnK1  | LSP1     | Local Setpoint - Loop 1   |
| 27                                  | PMnK2  | PB1      | Proportional Band - Loop 1  |
| 28                                  | PMnK3  | TI1      | Reset Action - Loop 1   |
| 29                                  | PMnK4  | TD1      | Rate Action - Loop 1  |
| 30                                  | PMnK5  | BSB1     | Change of Setpoint During Standby - Loop 1                              |
| 31                                  | PMnK6  | BOF1     | Change of Setpoint During Off - Loop 1                                  |
| 33                                  | PMnK8  | EDB1     | Error Deadband - Loop 1   |
| 34                                  | PMnK9  | OB1      | Output Bias - Loop 1  |
| 35                                  | PMnK10 | MNWS     | Minimum Working Setpoint (Version 1.1 or Later)                         |
| 36                                  | PMnK11 | HIL1     | Upper Limit of the Control Output - Loop 1                              |
| 37                                  | PMnK12 | LOL1     | Lower Limit of the Control Output - Loop 1                              |
| 38                                  | PMnK13 | DHH1     | Deviation High High Alarm Value - Loop 1                                |
| 39                                  | PMnK14 | DH1      | Deviation High Alarm Value - Loop 1                                     |
| 40                                  | PMnK15 | DL1      | Deviation Low Alarm Value - Loop 1                                      |
| <b>Continued on next page . . .</b> |        |          |   |

| RI. Cont.)                          | PM Tag | Alg. Tag | Description                                     |          |
|-------------------------------------|--------|----------|---|----------|
| 41                                  | PMnK16 | DLL1     | Deviation Low Low Alarm Value                   | - Loop 1 |
| 42                                  | PMnK17 | MXWS     | Maximum Working Setpoint (Version 1.1 or Later) |          |
| 43                                  | PMnK18 | LSP2     | Local Setpoint                                  | - Loop 2 |
| 44                                  | PMnK19 | PB2      | Proportional Band                               | - Loop 2 |
| 45                                  | PMnK20 | TI2      | Reset Action                                    | - Loop 2 |
| 46                                  | PMnK21 | TD2      | Rate Action                                     | - Loop 2 |
| 47                                  | PMnK22 | BSB2     | Change of Setpoint During Standby               | - Loop 2 |
| 48                                  | PMnK23 | BOF2     | Change of Setpoint During Off                   | - Loop 2 |
| 49                                  | PMnK24 | EDB2     | Error Deadband                                  | - Loop 2 |
| 50                                  | PMnK25 | OB2      | Output Bias                                     | - Loop 2 |
| 51                                  | PMnK26 | SOL      | Shutoff Output Level                            |          |
| 52                                  | PMnK27 | STL      | Startup Output Level                            |          |
| 53                                  | PMnK28 | HIL2     | Upper Limit of the Control Output               | - Loop 2 |
| 54                                  | PMnK29 | LOL2     | Lower Limit of the Control Output               | - Loop 2 |
| 55                                  | PMnK30 | DHH2     | Deviation High High Alarm Value                 | - Loop 2 |
| 56                                  | PMnK31 | DH2      | Deviation High Alarm Value                      | - Loop 2 |
| 57                                  | PMnK32 | DL2      | Deviation Low Alarm Value                       | - Loop 2 |
| 58                                  | PMnK33 | DLL2     | Deviation Low Low Alarm Value                   | - Loop 2 |
| 59                                  | PMnK34 | EFL      | External Force Output Level                     |          |
| 60                                  | PMnOU1 | OCM      | Control Output (Active Loop)                    |          |
| 61                                  | PMnOU2 | WSP1     | Working Setpoint                                | - Loop 1 |
| 62                                  | PMnOU3 | WSP2     | Working Setpoint                                | - Loop 2 |
| 63                                  | PMnOU4 | PV       | Actual Process Variable                         |          |
| 64                                  | PMnOU5 | PVS      | PV Gain (100/Span)                              |          |
| 65                                  | PMnOU6 | PVL      | PV Low Range                                    |          |
| 66                                  | PMnOU7 | RSP      | Actual Remote Setpoint                          |          |
| 67                                  | PMnOU8 | RV       | Actual Reference Variable                       |          |
| 68                                  | PMnAX1 | OCM1     | Control Output                                  | - Loop 1 |
| 69                                  | PMnAX2 | OCM2     | Control Output                                  | - Loop 2 |
| 70                                  | PMnHDC |          | Hold Mode Control/Status                        |          |
|                                     |        |          | 0   | 0        |
|                                     |        |          | 0   | 0        |
|                                     |        |          | 0   | 0        |
|                                     |        |          | 0   | 0        |
|                                     |        |          | 0   | 0        |
|                                     |        |          | 0   | 0        |
|                                     |        |          | X2  | X1       |
|                                     |        | HLD      | X1 = 1  |          |
|                                     |        | CMP      | X2 = 1  |          |
| <b>Continued on next page . . .</b> |        |          |   |          |

| RI.<br>(Cont.) | PM Tag | Alg.<br>Tag | Description       |                                 |     |     |     |     |     |    |
|----------------|--------|-------------|-------------------|---------------------------------|-----|-----|-----|-----|-----|----|
| 72             | PMnST  |             | Controller Status |                                 |     |     |     |     |     |    |
|                |        |             | 0                 | X15                             | X14 | X13 | X12 | X11 | X10 | X9 |
|                |        |             | X8                | X7                              | X6  | X5  | 0   | X3  | X2  | X1 |
|                |        | CML         | X1 = 1            | Controller Output at Low Limit  |     |     |     |     |     |    |
|                |        | CMH         | X2 = 1            | Controller Output at High Limit |     |     |     |     |     |    |
|                |        | FORC        | X3 = 1            | Force-Back to OCM Active        |     |     |     |     |     |    |
|                |        | LLDA        | X5 = 1            | Deviation Alarm Low Low         |     |     |     |     |     |    |
|                |        | LDA         | X6 = 1            | Deviation Alarm Low             |     |     |     |     |     |    |
|                |        | HDA         | X7 = 1            | Deviation Alarm High            |     |     |     |     |     |    |
|                |        | HHDA        | X8 = 1            | Deviation Alarm High High       |     |     |     |     |     |    |
|                |        | SOF         | X9 = 1            | Shutoff Mode Active             |     |     |     |     |     |    |
|                |        | STA         | X10= 1            | Startup Mode Active             |     |     |     |     |     |    |
|                |        | EF          | X11= 1            | External Forcing Active         |     |     |     |     |     |    |
|                |        | OF          | X12= 1            | Off Mode Active                 |     |     |     |     |     |    |
|                |        | SB          | X13= 1            | Standby Mode Active             |     |     |     |     |     |    |
|                |        | RA          | X14= 1            | Reverse Action Mode             |     |     |     |     |     |    |
|                |        | HEAT        | X15= 1            | Heating Mode (RA)               |     |     |     |     |     |    |

**Algorithm 4 -  
Heating/Cooling  
On/Off  
Controller**

**Table 49: Algorithm 4 - Heating/Cooling On/Off Controller**

| RI.                                 | PM Tag | Alg.<br>Tag | Description         |                                |    |   |    |    |    |    |
|-------------------------------------|--------|-------------|---------------------|--------------------------------|----|---|----|----|----|----|
| 00                                  | PMnTYP | TYP         | Algorithm Type = 04 |                                |    |   |    |    |    |    |
| 01                                  | PMnOPT | OPT         | Controller Options  |                                |    |   |    |    |    |    |
|                                     |        |             | 0                   | 0                              | 0  | 0 | 0  | 0  | 0  | 0  |
|                                     |        |             | X8                  | 0                              | X6 | 0 | X4 | X3 | X2 | X1 |
|                                     |        | SOFE        | X1 = 1              | Enable Shutoff Mode            |    |   |    |    |    |    |
|                                     |        | SOFL        | X2 = 0              | Shutoff Out Level = 0          |    |   |    |    |    |    |
|                                     |        | SOFL        | X2 = 1              | Shutoff Out Level = 1          |    |   |    |    |    |    |
|                                     |        | STAE        | X3 = 1              | Enable Startup Mode            |    |   |    |    |    |    |
|                                     |        | STAL        | X4 = 0              | Startup Out Level = 0          |    |   |    |    |    |    |
|                                     |        | STAL        | X4 = 1              | Startup Out Level = 1          |    |   |    |    |    |    |
|                                     |        | EFL         | X6 = 0              | External Forcing Out Level = 0 |    |   |    |    |    |    |
|                                     |        | EFL         | X6 = 1              | External Forcing Out Level = 1 |    |   |    |    |    |    |
|                                     |        | REM         | X8 = 1              | Remote Mode                    |    |   |    |    |    |    |
|                                     |        | SOTO        | X9 = 1              | Enable Shutoff to Off Change   |    |   |    |    |    |    |
| <b>Continued on next page . . .</b> |        |             |                     |                                |    |   |    |    |    |    |

| RI.<br>(Cont.)                      | PM Tag | Alg.<br>Tag | Description  |          |
|-------------------------------------|--------|-------------|--|----------|
| 10                                  | PMn11@ | PV@         | Process Variable Connection                                |          |
| 11                                  | PMn12@ | RS1@        | Remote Setpoint Connection                                 | - Loop 1 |
| 12                                  | PMn13@ | RV1@        | Reference Variable Connection                              | - Loop 1 |
| 14                                  | PMn15@ | OF@         | Off Mode Logic Control Connection                          |          |
| 15                                  | PMn16@ | SB@         | Standby Mode Logic Control Connection                      |          |
| 16                                  | PMn17@ | RA@         | Reverse Acting Logic Control Connection                    |          |
| 17                                  | PMn18@ | EF@         | External Forcing Logic Control Connection                  |          |
| 18                                  | PMn19@ | RS2@        | Remote Setpoint Connection                                 | - Loop 2 |
| 19                                  | PMn10@ | RV2@        | Reference Variable Connection                              | - Loop 2 |
| 22                                  | PMn13@ | MNWS@       | Minimum Working Setpoint Connection (Version 1.1 or Later) |          |
| 23                                  | PMn14@ | MXWS@       | Maximum Working Setpoint Connection (Version 1.1 or Later) |          |
| 26                                  | PMnK01 | LSP1        | Local Setpoint   |          |
| 27                                  | PMnK02 | ACT1        | Action Mode  | - Loop 1 |
| 28                                  | PMnK03 | DIF1        | Differential   | - Loop 1 |
| 30                                  | PMnK05 | BSB1        | Change of Setpoint During Standby                          | - Loop 1 |
| 31                                  | PMnK06 | BOF1        | Change of Setpoint During Off                              | - Loop 1 |
| 35                                  | PMnK10 | MNWS        | Minimum Working Setpoint (Version 1.1 or Later)            |          |
| 38                                  | PMnK13 | DHH1        | Deviation High High Alarm Value                            | - Loop 1 |
| 39                                  | PMnK14 | DH1         | Deviation High Alarm Value                                 | - Loop 1 |
| 40                                  | PMnK15 | DL1         | Deviation Low Alarm Value                                  | - Loop 1 |
| 41                                  | PMnK16 | DLL1        | Deviation Low Low Alarm Value                              | - Loop 1 |
| 42                                  | PMnK17 | MXWS        | Maximum Working Setpoint (Version 1.1 or Later)            |          |
| 43                                  | PMnK18 | LSP2        | Local Setpoint   | - Loop 2 |
| 44                                  | PMnK19 | ACT2        | Action Mode  | - Loop 2 |
| 45                                  | PMnK20 | DIF2        | Differential   | - Loop 2 |
| 47                                  | PMnK22 | BSB2        | Change of Setpoint During Standby                          | - Loop 2 |
| 48                                  | PMnK23 | BOF2        | Change of Setpoint During Off                              | - Loop 2 |
| 55                                  | PMnK30 | DHH2        | Deviation High High Alarm Value                            | - Loop 2 |
| <b>Continued on next page . . .</b> |        |             |  |          |

| RI.<br>(Cont.) | PM Tag | Alg.<br>Tag | Description                      |                              |
|----------------|--------|-------------|----------------------------------|------------------------------|
| 56             | PMnK31 | DH2         | Deviation High Alarm Value       | - Loop 2                     |
| 57             | PMnK32 | DL2         | Deviation Low Alarm Value        | - Loop 2                     |
| 58             | PMnK33 | DLL2        | Deviation Low Low Alarm Value    | - Loop 2                     |
|                |        |             |                                  |                              |
| 61             | PMnOU2 | WSP1        | Working Setpoint                 | - Loop 1                     |
| 62             | PMnOU3 | WSP2        | Working Setpoint                 | - Loop 2                     |
| 63             | PMnOU4 | PV          | Actual Process Variable          |                              |
| 64             | PMnOU5 | PVS         | PV Gain (100/Span)               |                              |
| 65             | PMnOU6 | PVL         | PV Low Range                     |                              |
| 66             | PMnOU7 | RSP         | Actual Remote Setpoint           |                              |
| 67             | PMnOU8 | RV          | Actual Reference Variable        |                              |
|                |        |             |                                  |                              |
| 70             | PMnHDC |             | Hold Mode Control/Status         |                              |
|                |        |             | 0 0 0 0 0 0 X2 X1                |                              |
|                |        | HLD         | X1 = 1                           | Hold Control/Status          |
|                |        | CMP         | X2 = 1                           | Computer Mode Request        |
|                |        |             |                                  |                              |
| 71             | PMnDO  |             | Logic Outputs Control and Status |                              |
|                |        |             | 0 0 0 0 X4 X3 0 X1               |                              |
|                |        | OCM         | X1                               | Control Output (Active Loop) |
|                |        | OCM1        | X3                               | Control Output - Loop 1      |
|                |        | OCM2        | X4                               | Control Output - Loop 2      |
|                |        |             |                                  |                              |
| 72             | PMnST  |             | Controller Status                |                              |
|                |        | CML         | X1 = 1                           | Controller Output at 0       |
|                |        | CMH         | X2 = 1                           | Controller Output at 1       |
|                |        | LLDA        | X5 = 1                           | Deviation Alarm Low Low      |
|                |        | LDA         | X6 = 1                           | Deviation Alarm Low          |
|                |        | HDA         | X7 = 1                           | Deviation Alarm High         |
|                |        | HHDA        | X8 = 1                           | Deviation Alarm High High    |
|                |        | SOF         | X9 = 1                           | Shutoff Mode Active          |
|                |        | STA         | X10= 1                           | Startup Mode Active          |
|                |        | EF          | X11= 1                           | External Forcing Active      |
|                |        | OF          | X12= 1                           | Off Mode Active              |
|                |        | SB          | X13= 1                           | Standby Mode Active          |
|                |        | RA          | X14= 1                           | Reverse Action Mode          |
|                |        | HEAT        | X15= 1                           | Heating Mode (RA)            |

**Algorithm 11 -  
Average  
Calculation**

**Table 50: Algorithm 11 - Average Calculation**

| RI. | PM Tag | Alg. Tag | Description                            |
|-----|--------|----------|--|
| 00  | PMnTYP | TYP      | Algorithm Type = 11                    |
| 10  | PMnI1@ | I1@      | Input 1 Analog Connection              |
| 11  | PMnI2@ | I2@      | Input 2 Analog Connection              |
| 12  | PMnI3@ | I3@      | Input 3 Analog Connection              |
| 13  | PMnI4@ | I4@      | Input 4 Analog Connection              |
| 14  | PMnI5@ | I5@      | Input 5 Analog Connection              |
| 15  | PMnI6@ | I6@      | Input 6 Analog Connection              |
| 16  | PMnI7@ | I7@      | Input 7 Analog Connection              |
| 17  | PMnI8@ | I8@      | Input 8 Analog Connection              |
| 26  | PMnK1  | K0       | Constant                               |
| 27  | PMnK2  | K1       | Constant                               |
| 28  | PMnK3  | K2       | Constant                               |
| 29  | PMnK4  | K3       | Constant                               |
| 30  | PMnK5  | K4       | Constant                               |
| 31  | PMnK6  | K5       | Constant                               |
| 32  | PMnK7  | K6       | Constant                               |
| 33  | PMnK8  | K7       | Constant                               |
| 34  | PMnK9  | K8       | Constant                               |
| 36  | PMnK11 | HIL      | Upper Limit of the Calculated Output   |
| 37  | PMnK12 | LOL      | Lower Limit of the Calculated Output   |
| 60  | PMnOU1 | NCM      | Calculated Output                      |
| 70  | PMnHDC |          | Hold Mode Control/Status               |
|     |        |          | 0 0 0 0 0 0 0 X1                       |
|     |        | HLD      | X1 = 1 Hold Control/Status             |
| 72  | PMnST  |          | Programmable Function Module Status    |
|     |        |          | 0 0 0 0 0 0 0 0                        |
|     |        |          | 0 0 0 0 0 0 X2 X1                      |
|     |        | NML      | X1 = 1 Calculated Output at Low Limit  |
|     |        | NMH      | X2 = 1 Calculated Output at High Limit |



**Algorithm 12 -  
Minimum  
Selection**

**Table 51: Algorithm 12 - Minimum Selection**

| RI. | PM Tag | Alg. Tag | Description                            |
|-----|--------|----------|--|
| 00  | PMnTYP | TYP      | Algorithm Type = 12                    |
| 10  | PMnI1@ | I1@      | Input 1 Analog Connection              |
| 11  | PMnI2@ | I2@      | Input 2 Analog Connection              |
| 12  | PMnI3@ | I3@      | Input 3 Analog Connection              |
| 13  | PMnI4@ | I4@      | Input 4 Analog Connection              |
| 14  | PMnI5@ | I5@      | Input 5 Analog Connection              |
| 15  | PMnI6@ | I6@      | Input 6 Analog Connection              |
| 16  | PMnI7@ | I7@      | Input 7 Analog Connection              |
| 17  | PMnI8@ | I8@      | Input 8 Analog Connection              |
| 26  | PMnK1  | K0       | Constant                               |
| 27  | PMnK2  | K1       | Constant                               |
| 28  | PMnK3  | K2       | Constant                               |
| 29  | PMnK4  | K3       | Constant                               |
| 30  | PMnK5  | K4       | Constant                               |
| 31  | PMnK6  | K5       | Constant                               |
| 32  | PMnK7  | K6       | Constant                               |
| 33  | PMnK8  | K7       | Constant                               |
| 34  | PMnK9  | K8       | Constant                               |
|     |        |          |  |
| 36  | PMnK11 | HIL      | Upper Limit of the Calculated Output   |
| 37  | PMnK12 | LOL      | Lower Limit of the Calculated Output   |
|     |        |          |  |
| 60  | PMnOU1 | NCM      | Calculated Output                      |
|     |        |          |  |
| 70  | PMnHDC |          | Hold Mode Control/Status               |
|     |        |          | 0 0 0 0 0 0 0 X1                       |
|     |        | HLD      | X1 = 1 Hold Control/Status             |
|     |        |          |  |
| 72  | PMnST  |          | Programmable Function Module Status    |
|     |        |          | 0 0 0 0 0 0 0 0                        |
|     |        |          | 0 0 0 0 0 0 X2 X1                      |
|     |        | NML      | X1 = 1 Calculated Output at Low Limit  |
|     |        | NMH      | X2 = 1 Calculated Output at High Limit |

**Algorithm 13 -  
Maximum  
Selection**

**Table 52: Algorithm 13 - Maximum Selection**

| RI. | PM Tag | Alg. Tag | Description                            |
|-----|--------|----------|--|
| 00  | PMnTYP | TYP      | Algorithm Type = 13                    |
| 10  | PMnI1@ | I1@      | Input 1 Analog Connection              |
| 11  | PMnI2@ | I2@      | Input 2 Analog Connection              |
| 12  | PMnI3@ | I3@      | Input 3 Analog Connection              |
| 13  | PMnI4@ | I4@      | Input 4 Analog Connection              |
| 14  | PMnI5@ | I5@      | Input 5 Analog Connection              |
| 15  | PMnI6@ | I6@      | Input 6 Analog Connection              |
| 16  | PMnI7@ | I7@      | Input 7 Analog Connection              |
| 17  | PMnI8@ | I8@      | Input 8 Analog Connection              |
| 26  | PMnK1  | K0       | Constant                               |
| 27  | PMnK2  | K1       | Constant                               |
| 28  | PMnK3  | K2       | Constant                               |
| 29  | PMnK4  | K3       | Constant                               |
| 30  | PMnK5  | K4       | Constant                               |
| 31  | PMnK6  | K5       | Constant                               |
| 32  | PMnK7  | K6       | Constant                               |
| 33  | PMnK8  | K7       | Constant                               |
| 34  | PMnK9  | K8       | Constant                               |
|     |        |          |  |
| 36  | PMnK11 | HIL      | Upper Limit of the Calculated Output   |
| 37  | PMnK12 | LOL      | Lower Limit of the Calculated Output   |
|     |        |          |  |
| 60  | PMnOU1 | NCM      | Calculated Output                      |
|     |        |          |  |
| 70  | PMnHDC |          | Hold Mode Control/Status               |
|     |        |          | 0 0 0 0 0 0 0 X1                       |
|     |        | HLD      | X1 = 1 Hold Control/Status             |
|     |        |          |  |
| 72  | PMnST  |          | Programmable Function Module Status    |
|     |        |          | 0 0 0 0 0 0 0 0                        |
|     |        |          | 0 0 0 0 0 0 X2 X1                      |
|     |        | NML      | X1 = 1 Calculated Output at Low Limit  |
|     |        | NMH      | X2 = 1 Calculated Output at High Limit |

**Algorithm 14 -  
Psychrometric  
Calculation °C**

**Table 53: Algorithm 14 - Psychrometric Calculation °C**

| RI. | PM Tag | Alg. Tag | Description                                      |
|-----|--------|----------|--|
| 00  | PMnTYP | TYP      | Algorithm Type = 14                              |
| 02  | PMnF1  | FUN1     | Function Channel 1                               |
|     |        |          | 0 0 0 0 0 X3 X2 X1                               |
|     |        |          | X3 X2 X1 = 000 Not Used                          |
|     |        |          | = 001 Enthalpy                                   |
|     |        |          | = 010 Wet Bulb                                   |
|     |        |          | = 011 Dew Point                                  |
| 03  | PMnF2  | FUN2     | Function Channel 2                               |
|     |        |          | 0 0 0 0 0 X3 X2 X1                               |
|     |        |          | X3 X2 X1 = 000 Not Used                          |
|     |        |          | = 001 Enthalpy                                   |
| 10  | PMnI1@ | TM1@     | Input 1 - Temperature Connection Channel 1       |
| 11  | PMnI2@ | RH1@     | Input 2 - Humidity Connection Channel 1          |
| 12  | PMnI3@ | TM2@     | Temperature Connection Channel 2                 |
| 13  | PMnI4@ | RH2@     | Relative Humidity Connection Channel 2           |
| 36  | PMnK11 | HIL1     | Upper Limit of the Calculated Output Channel 1   |
| 37  | PMnK12 | LOL1     | Lower Limit of the Calculated Output Channel 1   |
| 38  | PMnK13 | ATP1     | Atmospheric Pressure Channel 1 (mbar)            |
| 53  | PMnK28 | HIL2     | Upper Limit of the Calculated Output Channel 1   |
| 54  | PMnK29 | LOL2     | Lower Limit of the Calculated Output Channel 1   |
| 55  | PMnK30 | ATP2     | Atmospheric Pressure Channel 2 (mbar)            |
| 60  | PMnOU1 | NCM1     | Calculated Output Channel 1                      |
| 61  | PMnOU2 | NCM2     | Calculated Output Channel 2                      |
| 70  | PMnHDC |          | Hold Mode Control/Status                         |
|     |        |          | 0 0 0 0 0 0 X2 X1                                |
|     |        | HLD1     | X1 = 1 Hold Channel 1                            |
|     |        | HLD2     | X2 = 1 Hold Channel 2                            |
| 72  | PMnST  |          | Programmable Function Module Status              |
|     |        |          | 0 0 0 0 0 0 0 0                                  |
|     |        |          | 0 0 0 0 X4 X3 X2 X1                              |
|     |        | NML1     | X1 = 1 Calculated Output at Low Limit Channel 1  |
|     |        | NMH1     | X2 = 1 Calculated Output at High Limit Channel 1 |
|     |        | NML2     | X3 = 1 Calculated Output at Low Limit Channel 2  |
|     |        | NMH2     | X4 = 1 Calculated Output at High Limit Channel 2 |

Notes: Channel 2 is only available in the DX-9100, Version 1.1 or later, and provides only an enthalpy calculation.

Only one Algorithm 14 or 15 may be configured in a DX controller.

**Algorithm 15 -  
Psychrometric  
Calculation °F**

**Table 54: Algorithm 15 - Psychrometric Calculation °F**

| RI. | PM Tag | Alg. Tag | Description                                      |
|-----|--------|----------|--|
| 00  | PMnTYP | TYP      | Algorithm Type = 15                              |
| 02  | PMnF1  | FUN1     | Function Channel 1                               |
|     |        |          | 0 0 0 0 0 X3 X2 X1                               |
|     |        |          | X3 X2 X1 = 000 Not Used                          |
|     |        |          | = 001 Enthalpy                                   |
|     |        |          | = 010 Wet Bulb                                   |
|     |        |          | = 011 Dew Point                                  |
| 03  | PMnF2  | FUN2     | Function Channel 2                               |
|     |        |          | 0 0 0 0 0 X3 X2 X1                               |
|     |        |          | X3 X2 X1 = 000 Not Used                          |
|     |        |          | = 001 Enthalpy                                   |
| 10  | PMn1@  | TM1@     | Input 1 - Temperature Connection Channel 1       |
| 11  | PMn2@  | RH1@     | Input 2 - Humidity Connection Channel 1          |
| 12  | PMn3@  | TM2@     | Temperature Connection Channel 2                 |
| 13  | PMn4@  | RH2@     | Relative Humidity Connection Channel 2           |
| 36  | PMnK11 | HIL1     | Upper Limit of the Calculated Output Channel 1   |
| 37  | PMnK12 | LOL1     | Lower Limit of the Calculated Output Channel 1   |
| 38  | PMnK13 | ATP1     | Atmospheric Pressure Channel 1 (mbar)            |
| 53  | PMnK28 | HIL2     | Upper Limit of the Calculated Output Channel 1   |
| 54  | PMnK29 | LOL2     | Lower Limit of the Calculated Output Channel 1   |
| 55  | PMnK30 | ATP2     | Atmospheric Pressure Channel 2 (mbar)            |
| 60  | PMnOU1 | NCM1     | Calculated Output Channel 1                      |
| 61  | PMnOU2 | NCM2     | Calculated Output Channel 2                      |
| 70  | PMnHDC |          | Hold Mode Control/Status                         |
|     |        |          | 0 0 0 0 0 0 X2 X1                                |
|     |        | HLD1     | X1 = 1 Hold Channel 1                            |
|     |        | HLD2     | X2 = 1 Hold Channel 2                            |
| 72  | PMnST  |          | Programmable Function Module Status              |
|     |        |          | 0 0 0 0 0 0 0 0                                  |
|     |        |          | 0 0 0 0 X4 X3 X2 X1                              |
|     |        | NML1     | X1 = 1 Calculated Output at Low Limit Channel 1  |
|     |        | NMH1     | X2 = 1 Calculated Output at High Limit Channel 1 |
|     |        | NML2     | X3 = 1 Calculated Output at Low Limit Channel 2  |
|     |        | NMH2     | X4 = 1 Calculated Output at High Limit Channel 2 |

Notes: Channel 2 is only available in the DX-9100, Version 1.1 or later, and provides only an enthalpy calculation.

Only one Algorithm 14 or 15 may be configured in a DX controller.

**Algorithm 16 -  
Line Segment  
Function**

**Table 55: Algorithm 16 - Line Segment Function**

| RI. | PM Tag | Alg. Tag | Description                |
|-----|--------|----------|----------------------------|
| 00  | PMnTYP | TYP      | Algorithm Type = 16        |
| 01  | PMnOPT | OPT      | Algorithm Options          |
|     |        |          | X16 0 0 0 0 0 0 0          |
|     |        |          | 0 0 0 0 0 0 0 0            |
|     |        | NEXT     | X16= 1 Chain to Next PM    |
| 10  | PMnI1@ | I1@      | Input Connection           |
| 26  | PMnK1  | X0       | Input Break Point 0        |
| 27  | PMnK2  | Y0       | Output Break Point 0       |
| 28  | PMnK3  | X1       | Input Break Point 1        |
| 29  | PMnK4  | Y1       | Output Break Point 1       |
| 30  | PMnK5  | X2       | Input Break Point 2        |
| 31  | PMnK6  | Y2       | Output Break Point 2       |
| 32  | PMnK7  | X3       | Input Break Point 3        |
| 33  | PMnK8  | Y3       | Output Break Point 3       |
| 34  | PMnK9  | X4       | Input Break Point 4        |
| 35  | PMnK10 | Y4       | Output Break Point 4       |
| 36  | PMnK11 | X5       | Input Break Point 5        |
| 37  | PMnK12 | Y5       | Output Break Point 5       |
| 38  | PMnK13 | X6       | Input Break Point 6        |
| 39  | PMnK14 | Y6       | Output Break Point 6       |
| 40  | PMnK15 | X7       | Input Break Point 7        |
| 41  | PMnK16 | Y7       | Output Break Point 7       |
| 42  | PMnK17 | X8       | Input Break Point 8        |
| 43  | PMnK18 | Y8       | Output Break Point 8       |
| 44  | PMnK19 | X9       | Input Break Point 9        |
| 45  | PMnK20 | Y9       | Output Break Point 9       |
| 46  | PMnK21 | X10      | Input Break Point 10       |
| 47  | PMnK22 | Y10      | Output Break Point 10      |
| 48  | PMnK23 | X11      | Input Break Point 11       |
| 49  | PMnK24 | Y11      | Output Break Point 11      |
| 50  | PMnK25 | X12      | Input Break Point 12       |
| 51  | PMnK26 | Y12      | Output Break Point 12      |
| 52  | PMnK27 | X13      | Input Break Point 13       |
| 53  | PMnK28 | Y13      | Output Break Point 13      |
| 54  | PMnK29 | X14      | Input Break Point 14       |
| 55  | PMnK30 | Y14      | Output Break Point 14      |
| 56  | PMnK31 | X15      | Input Break Point 15       |
| 57  | PMnK32 | Y15      | Output Break Point 15      |
| 58  | PMnK33 | X16      | Input Break Point 16       |
| 59  | PMnK34 | Y16      | Output Break Point 16      |
| 60  | PMnOU1 | NCM      | Calculated Output          |
| 70  | PMnHDC |          | Hold Mode Control/Status   |
|     |        |          | 0 0 0 0 0 0 0 X1           |
|     |        | HLD      | X1 = 1 Hold Control/Status |

**Algorithm 17 -  
Input Selector**

**Table 56: Algorithm 17 - Input Selector**

| RI. | PM Tag | Alg. Tag | Description                            |
|-----|--------|----------|--|
| 00  | PMnTYP | TYP      | Algorithm Type = 17                    |
| 10  | PMnI1@ | I1@      | Input 1 Analog Connection              |
| 11  | PMnI2@ | I2@      | Input 2 Analog Connection              |
| 12  | PMnI3@ | I3@      | Input 3 Analog Connection              |
| 13  | PMnI4@ | I4@      | Input 4 Analog Connection              |
| 14  | PMnI5@ | I5@      | Input 5 Logic Connection               |
| 15  | PMnI6@ | I6@      | Input 6 Logic Connection               |
| 26  | PMnK1  | K1       | Constant                               |
| 27  | PMnK2  | C1       | Constant                               |
| 28  | PMnK3  | K2       | Constant                               |
| 29  | PMnK4  | C2       | Constant                               |
| 30  | PMnK5  | K3       | Constant                               |
| 31  | PMnK6  | C3       | Constant                               |
| 32  | PMnK7  | K4       | Constant                               |
| 33  | PMnK8  | C4       | Constant                               |
| 36  | PMnK11 | HIL      | Upper Limit of the Calculated Output   |
| 37  | PMnK12 | LOL      | Lower Limit of the Calculated Output   |
| 60  | PMnOU1 | NCM      | Calculated Output                      |
|     |        |          |  |
| 70  | PMnHDC |          | Hold Mode Control/Status               |
|     |        |          | 0 0 0 0 0 0 0 X1                       |
|     |        | HLD      | X1 = 1 Hold Control/Status             |
| 72  | PMnST  |          | Programmable Function Module Status    |
|     |        |          | 0 0 0 0 0 0 0 0                        |
|     |        |          | 0 0 0 0 0 0 X2 X1                      |
|     |        | NML      | X1 = 1 Calculated Output at Low Limit  |
|     |        | NMH      | X2 = 1 Calculated Output at High Limit |

**Algorithm 18 -  
Calculator**

**Table 57: Algorithm 18 - Calculator**

| RI. | PM Tag | Alg. Tag | Description                            |
|-----|--------|----------|--|
| 00  | PMnTYP | TYP      | Algorithm Type = 18                    |
| 02  | PMnF1  | FUN      | Function Type:                         |
|     |        |          | 0 0 0 0 0 0 0 X2 X1                    |
|     |        |          | X2 X1 = 00 Not Used                    |
|     |        |          | X2 X1 = 01 Equation 1                  |
|     |        |          | X2 X1 = 10 Equation 2                  |
| 10  | PMnI1@ | I1@      | Input 1 Analog Connection              |
| 11  | PMnI2@ | I2@      | Input 2 Analog Connection              |
| 12  | PMnI3@ | I3@      | Input 3 Analog Connection              |
| 13  | PMnI4@ | I4@      | Input 4 Analog Connection              |
| 14  | PMnI5@ | I5@      | Input 5 Analog Connection              |
| 15  | PMnI6@ | I6@      | Input 6 Analog Connection              |
| 16  | PMnI7@ | I7@      | Input 7 Analog Connection              |
| 17  | PMnI8@ | I8@      | Input 8 Analog Connection              |
| 26  | PMnK1  | K0       | Constant                               |
| 27  | PMnK2  | K1       | Constant                               |
| 28  | PMnK3  | K2       | Constant                               |
| 29  | PMnK4  | K3       | Constant                               |
| 30  | PMnK5  | K4       | Constant                               |
| 31  | PMnK6  | K5       | Constant                               |
| 32  | PMnK7  | K6       | Constant                               |
| 33  | PMnK8  | K7       | Constant                               |
| 34  | PMnK9  | K8       | Constant                               |
| 35  | PMnK10 | K9       | Constant                               |
| 36  | PMnK11 | HIL      | Upper Limit of the Calculated Output   |
| 37  | PMnK12 | LOL      | Lower Limit of the Calculated Output   |
| 60  | PMnOU1 | NCM      | Calculated Output                      |
| 70  | PMnHDC |          | Hold Mode Control/Status               |
|     |        |          | 0 0 0 0 0 0 0 0 X1                     |
|     |        | HLD      | X1 = 1 Hold Control/Status             |
| 72  | PMnST  |          | Programmable Function Module Status    |
|     |        |          | 0 0 0 0 0 0 0 0 0                      |
|     |        |          | 0 0 0 0 0 0 0 X2 X1                    |
|     |        | NML      | X1 = 1 Calculated Output at Low Limit  |
|     |        | NMH      | X2 = 1 Calculated Output at High Limit |

**Algorithm 19 -  
Timer Function**

**Table 58: Algorithm 19 - Timer Function**

| RI.                                 | PMn Tag | Alg. Tag | Description                     |
|-------------------------------------|---------|----------|---------------------------------|
| 00                                  | PMnTYP  | TYP      | Algorithm Type = 19             |
| 02                                  | PMnF1   | FUN1     | Function Channel 1              |
|                                     |         |          | 0 0 X6 X5 0 X3 X2 X1            |
|                                     |         |          | X3 X2 X1 = 000 Channel Disabled |
|                                     |         |          | = 001 Pulse                     |
|                                     |         |          | = 010 Retriggerable Pulse       |
|                                     |         |          | = 011 On Delay with Memory      |
|                                     |         |          | = 100 On Delay                  |
|                                     |         |          | = 101 Off Delay                 |
|                                     |         |          | X6 X5 = 00 Time in Seconds      |
|                                     |         |          | = 01 Time in Minutes            |
|                                     |         |          | = 10 Time in Hours              |
| 03                                  | PMnF2   | FUN2     | Function Channel 2 as FUN1      |
| 04                                  | PMnF3   | FUN3     | Function Channel 3 as FUN1      |
| 05                                  | PMnF4   | FUN4     | Function Channel 4 as FUN1      |
| 06                                  | PMnF5   | FUN5     | Function Channel 5 as FUN1      |
| 07                                  | PMnF6   | FUN6     | Function Channel 6 as FUN1      |
| 08                                  | PMnF7   | FUN7     | Function Channel 7 as FUN1      |
| 09                                  | PMnF8   | FUN8     | Function Channel 8 as FUN1      |
| 10                                  | PMnI1@  | I1@      | Input Connection Channel 1      |
| 11                                  | PMnI2@  | RS1@     | Reset Connection Channel 1      |
| 12                                  | PMnI3@  | I2@      | Input Connection Channel 2      |
| 13                                  | PMnI4@  | RS2@     | Reset Connection Channel 2      |
| 14                                  | PMnI5@  | I3@      | Input Connection Channel 3      |
| 15                                  | PMnI6@  | RS3@     | Reset Connection Channel 3      |
| 16                                  | PMnI7@  | I4@      | Input Connection Channel 4      |
| 17                                  | PMnI8@  | RS4@     | Reset Connection Channel 4      |
| 18                                  | PMnI9@  | I5@      | Input Connection Channel 5      |
| 19                                  | PMnI10@ | RS5@     | Reset Connection Channel 5      |
| 20                                  | PMnI11@ | I6@      | Input Connection Channel 6      |
| 21                                  | PMnI12@ | RS6@     | Reset Connection Channel 6      |
| <b>Continued on next page . . .</b> |         |          |                                 |



| RI.<br>(Cont.) | PM Tag      | Alg. Tag | Description                           |
|----------------|-------------|----------|---------------------------------------|
| 22             | PMnI13<br>@ | I7@      | Input Connection Channel 7            |
| 23             | PMnI14<br>@ | R7@      | Reset Connection Channel 7            |
| 24             | PMnI15<br>@ | I8@      | Input Connection Channel 8            |
| 25             | PMnI16<br>@ | RS8@     | Reset Connection Channel 8            |
| 26             | PMnK1       | T1       | Time Period Channel 1                 |
| 27             | PMnK2       | T2       | Time Period Channel 2                 |
| 28             | PMnK3       | T3       | Time Period Channel 3                 |
| 29             | PMnK4       | T4       | Time Period Channel 4                 |
| 30             | PMnK5       | T5       | Time Period Channel 5                 |
| 31             | PMnK6       | T6       | Time Period Channel 6                 |
| 32             | PMnK7       | T7       | Time Period Channel 7                 |
| 33             | PMnK8       | T8       | Time Period Channel 8                 |
| 60             | PMnOU1      | TIM1     | Time to the End Of Period - Channel 1 |
| 61             | PMnOU2      | TIM2     | Time to the End Of Period - Channel 2 |
| 62             | PMnOU3      | TIM3     | Time to the End Of Period - Channel 3 |
| 63             | PMnOU4      | TIM4     | Time to the End Of Period - Channel 4 |
| 64             | PMnOU5      | TIM5     | Time to the End Of Period - Channel 5 |
| 65             | PMnOU6      | TIM6     | Time to the End Of Period - Channel 6 |
| 66             | PMnOU7      | TIM7     | Time to the End Of Period - Channel 7 |
| 67             | PMnOU8      | TIM8     | Time to the End Of Period - Channel 8 |
| 70             | PMnHDC      |          | Hold Mode Control/Status              |
|                |             |          | X8 X7 X6 X5 X4 X3 X2 X1               |
|                |             | HLD1     | X1 = 1 Hold Channel 1                 |
|                |             | HLD2     | X2 = 1 Hold Channel 2                 |
|                |             | HLD3     | X3 = 1 Hold Channel 3                 |
|                |             | HLD4     | X4 = 1 Hold Channel 4                 |
|                |             | HLD5     | X5 = 1 Hold Channel 5                 |
|                |             | HLD6     | X6 = 1 Hold Channel 6                 |
|                |             | HLD7     | X7 = 1 Hold Channel 7                 |
|                |             | HLD8     | X8 = 1 Hold Channel 8                 |
| 71             | PMnDO       |          | Logic Outputs Control and Status      |
|                |             |          | X8 X7 X6 X5 X4 X3 X2 X1               |
|                |             | TDO1     | X1 Digital Output Channel 1           |
|                |             | TDO2     | X2 Digital Output Channel 2           |
|                |             | TDO3     | X3 Digital Output Channel 3           |
|                |             | TDO4     | X4 Digital Output Channel 4           |
|                |             | TDO5     | X5 Digital Output Channel 5           |
|                |             | TDO6     | X6 Digital Output Channel 6           |
|                |             | TDO7     | X7 Digital Output Channel 7           |
|                |             | TDO8     | X8 Digital Output Channel 8           |

**Algorithm 20 -  
Totalization**

**Table 59: Algorithm 20 - Totalization**

| RI.                                 | PM Tag  | Alg. Tag | Description  |
|-------------------------------------|---------|----------|--|
| 00                                  | PMnTYP  | TYP      | Algorithm Type = 20  |
| 02                                  | PMnF1   | FUN1     | Function Channel 1   |
|                                     |         |          | X8   0   0   0   0   X3   X2   X1                                      |
|                                     |         |          | X3 X2 X1 = 000 Channel Disabled  |
|                                     |         |          | = 001 Event Counter  |
|                                     |         |          | = 010 Integrator   |
|                                     |         |          | = 011 Time Counter   |
|                                     |         |          | X8 =1 Increment ACTn and Reset TOTn when FSSn=1 (Version 1.1 or Later) |
| 03                                  | PMnF2   | FUN2     | Function Channel 2 as FUN1   |
| 04                                  | PMnF3   | FUN3     | Function Channel 3 as FUN1   |
| 05                                  | PMnF4   | FUN4     | Function Channel 4 as FUN1   |
| 06                                  | PMnF5   | FUN5     | Function Channel 5 as FUN1   |
| 07                                  | PMnF6   | FUN6     | Function Channel 6 as FUN1   |
| 08                                  | PMnF7   | FUN7     | Function Channel 7 as FUN1   |
| 09                                  | PMnF8   | FUN8     | Function Channel 8 as FUN1   |
| 10                                  | PMnI1@  | I1@      | Input Connection Channel 1   |
| 11                                  | PMnI2@  | RS1@     | Reset Connection Channel 1   |
| 12                                  | PMnI3@  | I2@      | Input Connection Channel 2   |
| 13                                  | PMnI4@  | RS2@     | Reset Connection Channel 2   |
| 14                                  | PMnI5@  | I3@      | Input Connection Channel 3   |
| 15                                  | PMnI6@  | RS3@     | Reset Connection Channel 3   |
| 16                                  | PMnI7@  | I4@      | Input Connection Channel 4   |
| 17                                  | PMnI8@  | RS4@     | Reset Connection Channel 4   |
| 18                                  | PMnI9@  | I5@      | Input Connection Channel 5   |
| 19                                  | PMnI10@ | RS5@     | Reset Connection Channel 5   |
| 20                                  | PMnI11@ | I6@      | Input Connection Channel 6   |
| 21                                  | PMnI12@ | RS6@     | Reset Connection Channel 6   |
| 22                                  | PMnI13@ | I7@      | Input Connection Channel 7   |
| 23                                  | PMnI14@ | RS7@     | Reset Connection Channel 7   |
| 24                                  | PMnI15@ | I8@      | Input Connection Channel 8   |
| 25                                  | PMnI16@ | RS8@     | Reset Connection Channel 8   |
| <b>Continued on next page . . .</b> |         |          |  |

| RI.<br>(Cont.)                      | PM Tag | Alg. Tag | Description                            |
|-------------------------------------|--------|----------|--|
| 26                                  | PMnK1  | FSL1     | Full Scale Limit Channel 1             |
| 27                                  | PMnK2  | FSL2     | Full Scale Limit Channel 2             |
| 28                                  | PMnK3  | FSL3     | Full Scale Limit Channel 3             |
| 29                                  | PMnK4  | FSL4     | Full Scale Limit Channel 4             |
| 30                                  | PMnK5  | FSL5     | Full Scale Limit Channel 5             |
| 31                                  | PMnK6  | FSL6     | Full Scale Limit Channel 6             |
| 32                                  | PMnK7  | FSL7     | Full Scale Limit Channel 7             |
| 33                                  | PMnK8  | FSL8     | Full Scale Limit Channel 8             |
| 34                                  | PMnK09 | FTC1     | Scaling Factor/Time Constant Channel 1 |
| 35                                  | PMnK10 | FTC2     | Scaling Factor/Time Constant Channel 2 |
| 36                                  | PMnK11 | FTC3     | Scaling Factor/Time Constant Channel 3 |
| 37                                  | PMnK12 | FTC4     | Scaling Factor/Time Constant Channel 4 |
| 38                                  | PMnK13 | FTC5     | Scaling Factor/Time Constant Channel 5 |
| 39                                  | PMnK14 | FTC6     | Scaling Factor/Time Constant Channel 6 |
| 40                                  | PMnK15 | FTC7     | Scaling Factor/Time Constant Channel 7 |
| 41                                  | PMnK16 | FTC8     | Scaling Factor/Time Constant Channel 8 |
| 60                                  | PMnOU1 | TOT1     | Total - Channel 1                      |
| 61                                  | PMnOU2 | TOT2     | Total - Channel 2                      |
| 62                                  | PMnOU3 | TOT3     | Total - Channel 3                      |
| 63                                  | PMnOU4 | TOT4     | Total - Channel 4                      |
| 64                                  | PMnOU5 | TOT5     | Total - Channel 5                      |
| 65                                  | PMnOU6 | TOT6     | Total - Channel 6                      |
| 66                                  | PMnOU7 | TOT7     | Total - Channel 7                      |
| 67                                  | PMnOU8 | TOT8     | Total - Channel 8                      |
| 70                                  | PMnHDC |          | Hold Mode Control/Status               |
|                                     |        |          | X8   X7   X6   X5   X4   X3   X2   X1  |
|                                     |        | HLD1     | X1 = 1   Hold Channel 1                |
|                                     |        | HLD2     | X2 = 1   Hold Channel 2                |
|                                     |        | HLD3     | X3 = 1   Hold Channel 3                |
|                                     |        | HLD4     | X4 = 1   Hold Channel 4                |
|                                     |        | HLD5     | X5 = 1   Hold Channel 5                |
|                                     |        | HLD6     | X6 = 1   Hold Channel 6                |
|                                     |        | HLD7     | X7 = 1   Hold Channel 7                |
|                                     |        | HLD8     | X8 = 1   Hold Channel 8                |
| <b>Continued on next page . . .</b> |        |          |  |

| RI.<br>(Cont.) | PM Tag | Alg. Tag | Description  |     |                               |     |     |     |     |    |
|----------------|--------|----------|--|-----|-------------------------------|-----|-----|-----|-----|----|
| 72             | PMnST  |          | Programmable Function Module Status                  |     |                               |     |     |     |     |    |
|                |        |          | X16  | X15 | X14                           | X13 | X12 | X11 | X10 | X9 |
|                |        |          | X8   | X7  | X6                            | X5  | X4  | X3  | X2  | X1 |
|                |        | FSS1     | X1 = 1   |     | Full Scale Status - Channel 1 |     |     |     |     |    |
|                |        | FSS2     | X2 = 1   |     | Full Scale Status - Channel 2 |     |     |     |     |    |
|                |        | FSS3     | X3 = 1   |     | Full Scale Status - Channel 3 |     |     |     |     |    |
|                |        | FSS4     | X4 = 1   |     | Full Scale Status - Channel 4 |     |     |     |     |    |
|                |        | FSS5     | X5 = 1   |     | Full Scale Status - Channel 5 |     |     |     |     |    |
|                |        | FSS6     | X6 = 1   |     | Full Scale Status - Channel 6 |     |     |     |     |    |
|                |        | FSS7     | X7 = 1   |     | Full Scale Status - Channel 7 |     |     |     |     |    |
|                |        | FSS8     | X8 = 1   |     | Full Scale Status - Channel 8 |     |     |     |     |    |
| 73             | PMnAC1 | ACT1     | Accumulated Total - Channel 1 (Version 1.1 or Later) |     |                               |     |     |     |     |    |
| 74             | PMnAC2 | ACT2     | Accumulated Total - Channel 2 (Version 1.1 or Later) |     |                               |     |     |     |     |    |
| 75             | PMnAC3 | ACT3     | Accumulated Total - Channel 3 (Version 1.1 or Later) |     |                               |     |     |     |     |    |
| 76             | PMnAC4 | ACT4     | Accumulated Total - Channel 4 (Version 1.1 or Later) |     |                               |     |     |     |     |    |
| 77             | PMnAC5 | ACT5     | Accumulated Total - Channel 5 (Version 1.1 or Later) |     |                               |     |     |     |     |    |
| 78             | PMnAC6 | ACT6     | Accumulated Total - Channel 6 (Version 1.1 or Later) |     |                               |     |     |     |     |    |
| 79             | PMnAC7 | ACT7     | Accumulated Total - Channel 7 (Version 1.1 or Later) |     |                               |     |     |     |     |    |
| 80             | PMnAC8 | ACT8     | Accumulated Total - Channel 8 (Version 1.1 or Later) |     |                               |     |     |     |     |    |

**Algorithm 21 –  
Eight Channel  
Comparator**

**Table 60: Algorithm 21 – Eight Channel Comparator**

| RI.                                 | PM Tag  | Alg. Tag | Description                             |
|-------------------------------------|---------|----------|---|
| 00                                  | PMnTYP  | TYP      | Algorithm Type = 21                     |
| 02                                  | PMnF1   | FUN1     | Function Channel 1                      |
|                                     |         |          | 0 0 0 0 0 X3 X2 X1                      |
|                                     |         |          | X3 X2 X1 = 000 Channel Disabled         |
|                                     |         |          | = 001 High Limit                        |
|                                     |         |          | = 010 Low Limit                         |
|                                     |         |          | = 011 Equality Status                   |
|                                     |         |          | = 100 Dynamic Status                    |
| 03                                  | PMnF2   | FUN2     | Function Channel 2 as FUN1              |
| 04                                  | PMnF3   | FUN3     | Function Channel 3 as FUN1              |
| 05                                  | PMnF4   | FUN4     | Function Channel 4 as FUN1              |
| 06                                  | PMnF5   | FUN5     | Function Channel 5 as FUN1              |
| 07                                  | PMnF6   | FUN6     | Function Channel 6 as FUN1              |
| 08                                  | PMnF7   | FUN7     | Function Channel 7 as FUN1              |
| 09                                  | PMnF8   | FUN8     | Function Channel 8 as FUN1              |
| 10                                  | PMnI1@  | I1@      | Analog Input Connection Channel 1       |
| 11                                  | PMnI2@  | SP1@     | Setpoint Reference Connection Channel 1 |
| 12                                  | PMnI3@  | I2@      | Analog Input Connection Channel 2       |
| 13                                  | PMnI4@  | SP2@     | Setpoint Reference Connection Channel 2 |
| 14                                  | PMnI5@  | I3@      | Analog Input Connection Channel 3       |
| 15                                  | PMnI6@  | SP3@     | Setpoint Reference Connection Channel 3 |
| 16                                  | PMnI7@  | I4@      | Analog Input Connection Channel 4       |
| 17                                  | PMnI8@  | SP4@     | Setpoint Reference Connection Channel 4 |
| 18                                  | PMnI9@  | I5@      | Analog Input Connection Channel 5       |
| 19                                  | PMnI10@ | SP5@     | Setpoint Reference Connection Channel 5 |
| 20                                  | PMnI11@ | I6@      | Analog Input Connection Channel 6       |
| 21                                  | PMnI12@ | SP6@     | Setpoint Reference Connection Channel 6 |
| 22                                  | PMnI13@ | I7@      | Analog Input Connection Channel 7       |
| 23                                  | PMnI14@ | SP7@     | Setpoint Reference Connection Channel 7 |
| 24                                  | PMnI15@ | I8@      | Analog Input Connection Channel 8       |
| 25                                  | PMnI16@ | SP8@     | Setpoint Reference Connection Channel 8 |
| 26                                  | PMnK1   | SP1      | Setpoint Channel 1                      |
| <b>Continued on next page . . .</b> |         |          |   |

| RI.<br>(Cont.) | PM Tag | Alg. Tag | Description                         |    |                            |    |    |                |    |    |
|----------------|--------|----------|-------------------------------------|----|----------------------------|----|----|----------------|----|----|
| 27             | PMnK2  | DF1      | Differential                        |    |                            |    |    | Channel 1      |    |    |
| 28             | PMnK3  | SP2      | Setpoint                            |    |                            |    |    | Channel 2      |    |    |
| 29             | PMnK4  | DF2      | Differential                        |    |                            |    |    | Channel 2      |    |    |
| 30             | PMnK5  | SP3      | Setpoint                            |    |                            |    |    | Channel 3      |    |    |
| 31             | PMnK6  | DF3      | Differential                        |    |                            |    |    | Channel 3      |    |    |
| 32             | PMnK7  | SP4      | Setpoint                            |    |                            |    |    | Channel 4      |    |    |
| 33             | PMnK8  | DF4      | Differential                        |    |                            |    |    | Channel 4      |    |    |
| 34             | PMnK9  | SP5      | Setpoint                            |    |                            |    |    | Channel 5      |    |    |
| 35             | PMnK10 | DF5      | Differential                        |    |                            |    |    | Channel 5      |    |    |
| 36             | PMnK11 | SP6      | Setpoint                            |    |                            |    |    | Channel 6      |    |    |
| 37             | PMnK12 | DF6      | Differential                        |    |                            |    |    | Channel 6      |    |    |
| 38             | PMnK13 | SP7      | Setpoint                            |    |                            |    |    | Channel 7      |    |    |
| 39             | PMnK14 | DF7      | Differential                        |    |                            |    |    | Channel 7      |    |    |
| 40             | PMnK15 | SP8      | Setpoint                            |    |                            |    |    | Channel 8      |    |    |
| 41             | PMnK16 | DF8      | Differential                        |    |                            |    |    | Channel 8      |    |    |
| 60             | PMnOU1 | NCM1     | Deviation (I1-SP1) - Channel 1      |    |                            |    |    |                |    |    |
| 61             | PMnOU2 | NCM2     | Deviation (I2-SP2) - Channel 2      |    |                            |    |    |                |    |    |
| 62             | PMnOU3 | NCM3     | Deviation (I3-SP3) - Channel 3      |    |                            |    |    |                |    |    |
| 63             | PMnOU4 | NCM4     | Deviation (I4-SP4) - Channel 4      |    |                            |    |    |                |    |    |
| 64             | PMnOU5 | NCM5     | Deviation (I5-SP5) - Channel 5      |    |                            |    |    |                |    |    |
| 65             | PMnOU6 | NCM6     | Deviation (I6-SP6) - Channel 6      |    |                            |    |    |                |    |    |
| 66             | PMnOU7 | NCM7     | Deviation (I7-SP7) - Channel 7      |    |                            |    |    |                |    |    |
| 67             | PMnOU8 | NCM8     | Deviation (I8-SP8) - Channel 8      |    |                            |    |    |                |    |    |
| 70             | PMnHDC |          | Hold Mode Control/Status            |    |                            |    |    |                |    |    |
|                |        |          | X8                                  | X7 | X6                         | X5 | X4 | X3             | X2 | X1 |
|                |        | HLD1     | X1 = 1                              |    |                            |    |    | Hold Channel 1 |    |    |
|                |        | HLD2     | X2 = 1                              |    |                            |    |    | Hold Channel 2 |    |    |
|                |        | HLD3     | X3 = 1                              |    |                            |    |    | Hold Channel 3 |    |    |
|                |        | HLD4     | X4 = 1                              |    |                            |    |    | Hold Channel 4 |    |    |
|                |        | HLD5     | X5 = 1                              |    |                            |    |    | Hold Channel 5 |    |    |
|                |        | HLD6     | X6 = 1                              |    |                            |    |    | Hold Channel 6 |    |    |
|                |        | HLD7     | X7 = 1                              |    |                            |    |    | Hold Channel 7 |    |    |
|                |        | HLD8     | X8 = 1                              |    |                            |    |    | Hold Channel 8 |    |    |
| 72             | PMnST  |          | Programmable Function Module Status |    |                            |    |    |                |    |    |
|                |        |          | 0                                   | 0  | 0                          | 0  | 0  | 0              | 0  | 0  |
|                |        |          | X8                                  | X7 | X6                         | X5 | X4 | X3             | X2 | X1 |
|                |        | LS1      | X1                                  |    | Logical Status - Channel 1 |    |    |                |    |    |
|                |        | LS2      | X2                                  |    | Logical Status - Channel 2 |    |    |                |    |    |
|                |        | LS3      | X3                                  |    | Logical Status - Channel 3 |    |    |                |    |    |
|                |        | LS4      | X4                                  |    | Logical Status - Channel 4 |    |    |                |    |    |
|                |        | LS5      | X5                                  |    | Logical Status - Channel 5 |    |    |                |    |    |
|                |        | LS6      | X6                                  |    | Logical Status - Channel 6 |    |    |                |    |    |
|                |        | LS7      | X7                                  |    | Logical Status - Channel 7 |    |    |                |    |    |
|                |        | LS8      | X8                                  |    | Logical Status - Channel 8 |    |    |                |    |    |

**Algorithm 22 -  
Sequencer**

**Table 61: Algorithm 22 - Sequencer**

| RI.                                 | PM Tag  | Alg. Tag | Description                                     |
|-------------------------------------|---------|----------|---|
| 00                                  | PMnTYP  | TYP      | Algorithm Type = 22                             |
| 01                                  | PMnOPT  | OPT      | Algorithm Options                               |
|                                     |         |          | X16 0 0 0 0 0 0 X9                              |
|                                     |         |          | X8 X7 X6 X5 X4 X3 X2 X1                         |
|                                     |         | MODE     | X3 X2 X1      Algorithm Mode                    |
|                                     |         |          | = 000      Disabled                             |
|                                     |         |          | = 001      Step Mode (Last On, First Off)       |
|                                     |         |          | = 010      Sequential (First On, First Off)     |
|                                     |         |          | = 011      Binary Code                          |
|                                     |         |          | = 100      Equal Runtime                        |
|                                     |         |          | X6 = 1      Invert Stages in Set                |
|                                     |         |          | X7 = 1      TON and TOFF Apply to Sets Only     |
|                                     |         |          | X8 = 0      Analog Input                        |
|                                     |         |          | X8 = 1      Logic Input                         |
|                                     |         |          | X9 = 0      Proactive Control                   |
|                                     |         |          | X9 = 1      Retro-active Control                |
|                                     |         |          |   |
|                                     |         | NEXT     | X16= 1      Chain to Next PM                    |
|                                     |         |          |   |
| 02                                  | PMnF1   | NST1     | Number of Stages in Set (Stage 1 = 1st)         |
| 03                                  | PMnF2   | NST2     | Number of Stages in Set (Stage 2 = 1st)         |
| 04                                  | PMnF3   | NST3     | Number of Stages in Set (Stage 3 = 1st)         |
| 05                                  | PMnF4   | NST4     | Number of Stages in Set (Stage 4 = 1st)         |
| 06                                  | PMnF5   | NST5     | Number of Stages in Set (Stage 5 = 1st)         |
| 07                                  | PMnF6   | NST6     | Number of Stages in Set (Stage 6 = 1st)         |
| 08                                  | PMnF7   | NST7     | Number of Stages in Set (Stage 7 = 1st)         |
| 09                                  | PMnF8   | NST8     | Number of Stages in Set (Stage 8 = 1st)         |
| 10                                  | PMnI1@  | DIS1@    | Connection to Disable Output Stage 1            |
| 11                                  | PMnI2@  | DIS2@    | Connection to Disable Output Stage 2            |
| 12                                  | PMnI3@  | DIS3@    | Connection to Disable Output Stage 3            |
| 13                                  | PMnI4@  | DIS4@    | Connection to Disable Output Stage 4            |
| 14                                  | PMnI5@  | DIS5@    | Connection to Disable Output Stage 5            |
| 15                                  | PMnI6@  | DIS6@    | Connection to Disable Output Stage 6            |
| 16                                  | PMnI7@  | DIS7@    | Connection to Disable Output Stage 7            |
| 17                                  | PMnI8@  | DIS8@    | Connection to Disable Output Stage 8            |
| 18                                  | PMnI9@  | INC@     | Control Input 1 Connection (Increase or Analog) |
| 19                                  | PMnI10@ | DEC@     | Control Input 2 Connection (Decrease)           |
| 20                                  | PMnI11@ | FSD@     | Connection for Fast Step Down (or Off)          |
| <b>Continued on next page . . .</b> |         |          |   |

| RI.<br>(Cont.)                      | PM Tag | Alg. Tag | Description                                  |
|-------------------------------------|--------|----------|--|
| 26                                  | PMnK1  | OLF1     | Output Load Factor (%) Stage 1               |
| 27                                  | PMnK2  | OLF2     | Output Load Factor (%) Stage 2               |
| 28                                  | PMnK3  | OLF3     | Output Load Factor (%) Stage 3               |
| 29                                  | PMnK4  | OLF4     | Output Load Factor (%) Stage 4               |
| 30                                  | PMnK5  | OLF5     | Output Load Factor (%) Stage 5               |
| 31                                  | PMnK6  | OLF6     | Output Load Factor (%) Stage 6               |
| 32                                  | PMnK7  | OLF7     | Output Load Factor (%) Stage 7               |
| 33                                  | PMnK8  | OLF8     | Output Load Factor (%) Stage 8               |
| 34                                  | PMnK9  | T1       | First Set On Delay (sec.)                    |
| 35                                  | PMnK10 | T2       | Stage On Delay (sec.)                        |
| 36                                  | PMnK11 | T3       | Set On Delay (sec.)                          |
| 37                                  | PMnK12 | T4       | Stage Off Delay (sec.)                       |
| 38                                  | PMnK13 | T5       | Set Off Delay (sec.)                         |
| 39                                  | PMnK14 | T4F      | Fast Step Down Stage Delay(sec.)             |
| 40                                  | PMnK15 | T5F      | Fast Step Down Set Delay (sec.)              |
| 41                                  | PMnK16 | TON      | Minimum On Time (sec.)                       |
| 42                                  | PMnK17 | TOFF     | Minimum Off Time (sec.)                      |
| 43                                  | PMnK18 | MAXC     | Maximum Number of Switching Cycles /set/hour |
| 44                                  | PMnK19 | FLR      | Full Load Ramp Time (sec.)                   |
| 45                                  | PMnK20 | LDF      | Interstage Load Differential (%)             |
| 60                                  | PMnOU1 | OUT      | Requested Output %                           |
| 61                                  | PMnOU2 | OUTD     | Output Difference %                          |
| 62                                  | PMnOU3 | OUTS     | Switched Output %                            |
| 70                                  | PMnHDC |          | Hold Mode Control/Status                     |
|                                     |        |          | 0   0   0   0   0   0   0   X1               |
|                                     |        | HLD      | X1 = 1 Hold Module                           |
| 71                                  | PMnDO  | DOUT     | Logic Outputs Control and Status             |
|                                     |        |          | X8   X7   X6   X5   X4   X3   X2   X1        |
|                                     |        | STO1     | X1 DO Stage 1                                |
|                                     |        | STO2     | X2 DO Stage 2                                |
|                                     |        | STO3     | X3 DO Stage 3                                |
|                                     |        | STO4     | X4 DO Stage 4                                |
|                                     |        | STO5     | X5 DO Stage 5                                |
|                                     |        | STO6     | X6 DO Stage 6                                |
|                                     |        | STO7     | X7 DO Stage 7                                |
| <b>Continued on next page . . .</b> |        |          |  |



| RI.<br>(Cont.) | PM Tag | Alg. Tag | Description                           |
|----------------|--------|----------|---------------------------------------|
|                |        | STO8     | X8 DO Stage 8                         |
| 72             | PMnST  |          | Programmable Function Module Status   |
|                |        |          | X16 X15 X14 X13 X12 X11 X10 X9        |
|                |        |          | X8 X7 X6 X5 X4 X3 X2 X1               |
|                |        | DIS1     | X1 = 1 Output Stage 1 Disabled        |
|                |        | DIS2     | X2 = 1 Output Stage 2 Disabled        |
|                |        | DIS3     | X3 = 1 Output Stage 3 Disabled        |
|                |        | DIS4     | X4 = 1 Output Stage 4 Disabled        |
|                |        | DIS5     | X5 = 1 Output Stage 5 Disabled        |
|                |        | DIS6     | X6 = 1 Output Stage 6 Disabled        |
|                |        | DIS7     | X7 = 1 Output Stage 7 Disabled        |
|                |        | DIS8     | X8 = 1 Output Stage 8 Disabled        |
|                |        | MCS1     | X9 = 1 Stage 1 Maximum Cycles Status  |
|                |        | MCS2     | X10 = 1 Stage 2 Maximum Cycles Status |
|                |        | MCS3     | X11 = 1 Stage 3 Maximum Cycles Status |
|                |        | MCS4     | X12 = 1 Stage 4 Maximum Cycles Status |
|                |        | MCS5     | X13 = 1 Stage 5 Maximum Cycles Status |
|                |        | MCS6     | X14 = 1 Stage 6 Maximum Cycles Status |
|                |        | MCS7     | X15 = 1 Stage 7 Maximum Cycles Status |
|                |        | MCS8     | X16 = 1 Stage 8 Maximum Cycles Status |
| 73             | PMnAC1 | RT1      | Runtime Stage 1 (hours)               |
| 74             | PMnAC2 | RT2      | Runtime Stage 2 (hours)               |
| 75             | PMnAC3 | RT3      | Runtime Stage 3 (hours)               |
| 76             | PMnAC4 | RT4      | Runtime Stage 4 (hours)               |
| 77             | PMnAC5 | RT5      | Runtime Stage 5 (hours)               |
| 78             | PMnAC6 | RT6      | Runtime Stage 6 (hours)               |
| 79             | PMnAC7 | RT7      | Runtime Stage 7 (hours)               |
| 80             | PMnAC8 | RT8      | Runtime Stage 8 (hours)               |

**Algorithm 23 –  
Four Channel  
Line Segment  
Function**

**Table 62: Algorithm 23 – Four Channel Line Segment Function  
(DX-9100 Version 1.1 or Later)**

| RI.                                 | PMnTag | Alg. Tag | Description                  |   |
|-------------------------------------|--------|----------|------------------------------|---|
| 00                                  | PMnTYP | TYP      | Algorithm Tag = 23           |   |
| 10                                  | PMnI1@ | I1@      | Input Connection Channel 1   |   |
| 11                                  | PMnI2@ | I2@      | Input Connection Channel 2   |   |
| 12                                  | PMnI3@ | I3@      | Input Connection Channel 3   |   |
| 13                                  | PMnI4@ | I4@      | Input Connection Channel 4   |   |
| 26                                  | PMnK1  | X0-1     | Channel 1 Input Break Point  | 0 |
| 27                                  | PMnK2  | Y0-1     | Channel 1 Output Break Point | 0 |
| 28                                  | PMnK3  | X1-1     | Channel 1 Input Break Point  | 1 |
| 29                                  | PMnK4  | Y1-1     | Channel 1 Output Break Point | 1 |
| 30                                  | PMnK5  | X2-1     | Channel 1 Input Break Point  | 2 |
| 31                                  | PMnK6  | Y2-1     | Channel 1 Output Break Point | 2 |
| 32                                  | PMnK7  | X3-1     | Channel 1 Input Break Point  | 3 |
| 33                                  | PMnK8  | Y3-1     | Channel 1 Output Break Point | 3 |
| 34                                  | PMnK9  | X0-2     | Channel 2 Input Break Point  | 0 |
| 35                                  | PMnK10 | Y0-2     | Channel 2 Output Break Point | 0 |
| 36                                  | PMnK11 | X1-2     | Channel 2 Input Break Point  | 1 |
| 37                                  | PMnK12 | Y1-2     | Channel 2 Output Break Point | 1 |
| 38                                  | PMnK13 | X2-2     | Channel 2 Input Break Point  | 2 |
| 39                                  | PMnK14 | Y2-2     | Channel 2 Output Break Point | 2 |
| 40                                  | PMnK15 | X3-2     | Channel 2 Input Break Point  | 3 |
| 41                                  | PMnK16 | Y3-2     | Channel 2 Output Break Point | 3 |
| 42                                  | PMnK17 | X0-3     | Channel 3 Input Break Point  | 0 |
| 43                                  | PMnK18 | Y0-3     | Channel 3 Output Break Point | 0 |
| 44                                  | PMnK19 | X1-3     | Channel 3 Input Break Point  | 1 |
| 45                                  | PMnK20 | Y1-3     | Channel 3 Output Break Point | 1 |
| 46                                  | PMnK21 | X2-3     | Channel 3 Input Break Point  | 2 |
| 47                                  | PMnK22 | Y2-3     | Channel 3 Output Break Point | 2 |
| 48                                  | PMnK23 | X3-3     | Channel 3 Input Break Point  | 3 |
| 49                                  | PMnK24 | Y3-3     | Channel 3 Output Break Point | 3 |
| <b>Continued on next page . . .</b> |        |          |                              |   |

| RI.<br>(Cont.) | PM Tag | Alg. Tag | Description                    |
|----------------|--------|----------|--------------------------------|
| 50             | PMnK25 | X0-4     | Channel 4 Input Break Point 0  |
| 51             | PMnK26 | Y0-4     | Channel 4 Output Break Point 0 |
| 52             | PMnK27 | X1-4     | Channel 4 Input Break Point 1  |
| 53             | PMnK28 | Y1-4     | Channel 4 Output Break Point 1 |
| 54             | PMnK29 | X2-4     | Channel 4 Input Break Point 2  |
| 55             | PMnK30 | Y2-4     | Channel 4 Output Break Point 2 |
| 56             | PMnK31 | X3-4     | Channel 4 Input Break Point 3  |
| 57             | PMnK32 | Y3-4     | Channel 4 Output Break Point 3 |
| 60             | PMnOU1 | NCM1     | Output Channel 1               |
| 61             | PMnOU2 | NCM2     | Output Channel 2               |
| 62             | PMnOU3 | NCM3     | Output Channel 3               |
| 63             | PMnOU4 | NCM4     | Output Channel 4               |
| 70             | PMnHDC |          | Hold Mode Control/Status       |
|                |        |          | 0 0 0 0 X4 X3 X2 X1            |
|                |        | HLD1     | X1 = 1 Hold Channel 1          |
|                |        | HLD2     | X2 = 1 Hold Channel 2          |
|                |        | HLD3     | X3 = 1 Hold Channel 3          |
|                |        | HLD4     | X4 = 1 Hold Channel 4          |

**Algorithm 24 –  
Eight Channel  
Calculator**

**Table 63: Algorithm 24 – Eight Channel Calculator  
(DX-9100 Version 1.1 or Later)**

| RI.                                 | PMnTag  | Alg. Tag | Description                  |
|-------------------------------------|---------|----------|------------------------------|
| 00                                  | PMnTyp  | TYP      | Algorithm Type = 24          |
| 02                                  | PMnF1   | FUN1     | Function Channel 1           |
|                                     |         | 0 0 0    | 0 0 X3 X2 X1                 |
|                                     |         | X3 X2 X1 | = 000 Disabled               |
|                                     |         |          | = 001 Addition               |
|                                     |         |          | = 010 Subtraction            |
|                                     |         |          | = 011 Multiplication         |
|                                     |         |          | = 100 Division               |
|                                     |         |          | = 101 Minimum                |
|                                     |         |          | = 110 Maximum                |
| 03                                  | PMnF2   | FUN2     | Function Channel 2 as FUN1   |
| 04                                  | PMnF3   | FUN3     | Function Channel 3 as FUN1   |
| 05                                  | PMnF4   | FUN4     | Function Channel 4 as FUN1   |
| 06                                  | PMnF5   | FUN5     | Function Channel 5 as FUN1   |
| 07                                  | PMnF6   | FUN6     | Function Channel 6 as FUN1   |
| 08                                  | PMnF7   | FUN7     | Function Channel 7 as FUN1   |
| 09                                  | PMnF8   | FUN8     | Function Channel 8 as FUN1   |
| 10                                  | PMnI1@  | I1-1@    | Input Connection 1 Channel 1 |
| 11                                  | PMnI2@  | I2-1@    | Input Connection 2 Channel 1 |
| 12                                  | PMnI3@  | I1-2@    | Input Connection 1 Channel 2 |
| 13                                  | PMnI4@  | I2-2@    | Input Connection 2 Channel 2 |
| 14                                  | PMnI5@  | I1-3@    | Input Connection 1 Channel 3 |
| 15                                  | PMnI6@  | I2-3@    | Input Connection 2 Channel 3 |
| 16                                  | PMnI7@  | I1-4@    | Input Connection 1 Channel 4 |
| 17                                  | PMnI8@  | I2-4@    | Input Connection 2 Channel 4 |
| 18                                  | PMnI9@  | I1-5@    | Input Connection 1 Channel 5 |
| 19                                  | PMnI10@ | I2-5@    | Input Connection 2 Channel 5 |
| 20                                  | PMnI11@ | I1-6@    | Input Connection 1 Channel 6 |
| 21                                  | PMnI12@ | I2-6@    | Input Connection 2 Channel 6 |
| 22                                  | PMnI13@ | I1-7@    | Input Connection 1 Channel 7 |
| 23                                  | PMnI14@ | I2-7@    | Input Connection 2 Channel 7 |
| 24                                  | PMnI15@ | I1-8@    | Input Connection 1 Channel 8 |
| 25                                  | PMnI16@ | I2-8@    | Input Connection 2 Channel 8 |
| <b>Continued on next page . . .</b> |         |          |                              |

| RI.<br>(Cont.) | PM Tag | Alg. Tag | Description                           |
|----------------|--------|----------|---------------------------------------|
| 26             | PMnK1  | K1-1     | Constant 1 Channel 1                  |
| 27             | PMnK2  | K2-1     | Constant 2 Channel 1                  |
| 28             | PMnK3  | K1-2     | Constant 1 Channel 2                  |
| 29             | PMnK4  | K2-2     | Constant 2 Channel 2                  |
| 30             | PMnK5  | K1-3     | Constant 1 Channel 3                  |
| 31             | PMnK6  | K2-3     | Constant 2 Channel 3                  |
| 32             | PMnK7  | K1-4     | Constant 1 Channel 4                  |
| 33             | PMnK8  | K2-4     | Constant 2 Channel 4                  |
| 34             | PMnK9  | K1-5     | Constant 1 Channel 5                  |
| 35             | PMnK10 | K2-5     | Constant 2 Channel 5                  |
| 36             | PMnK11 | K1-6     | Constant 1 Channel 6                  |
| 37             | PMnK12 | K2-6     | Constant 2 Channel 6                  |
| 38             | PMnK13 | K1-7     | Constant 1 Channel 7                  |
| 39             | PMnK14 | K2-7     | Constant 2 Channel 7                  |
| 40             | PMnK15 | K1-8     | Constant 1 Channel 8                  |
| 41             | PMnK16 | K2-8     | Constant 2 Channel 8                  |
| 60             | PMnOU1 | NCM1     | Output Channel 1                      |
| 61             | PMnOU2 | NCM2     | Output Channel 2                      |
| 62             | PMnOU3 | NCM3     | Output Channel 3                      |
| 63             | PMnOU4 | NCM4     | Output Channel 4                      |
| 64             | PMnOU5 | NCM5     | Output Channel 5                      |
| 65             | PMnOU6 | NCM6     | Output Channel 6                      |
| 66             | PMnOU7 | NCM7     | Output Channel 7                      |
| 67             | PMnOU8 | NCM8     | Output Channel 8                      |
| 70             | PMnHDC |          | Hold Mode Control/Status              |
|                |        |          | X8   X7   X6   X5   X4   X3   X2   X1 |
|                |        | HLD1     | X1 = 1   Hold Channel 1               |
|                |        | HLD2     | X2 = 1   Hold Channel 2               |
|                |        | HLD3     | X3 = 1   Hold Channel 3               |
|                |        | HLD4     | X4 = 1   Hold Channel 4               |
|                |        | HLD5     | X5 = 1   Hold Channel 5               |
|                |        | HLD6     | X6 = 1   Hold Channel 6               |
|                |        | HLD7     | X7 = 1   Hold Channel 7               |
|                |        | HLD8     | X8 = 1   Hold Channel 8               |



# Appendix D: Logic Variables

---

---

## ***Description of Logic Variables***

The DX-9100 contains logic variables, representing the individual bits in status Items. They are listed for use as logical status connections and PLC parameters in the configuration of the DX-9100. Logic variables are referred to by a byte address with a label (corresponding to the label of the equivalent Status Item in the Item List), and a bit position. When using the GX Tool for the DX-9100, the user will refer to module tags and numbers and logic variable tags. Absolute addresses (byte address and bit position) are normally not required.

Note: When an address number is used for a connection inside the DX-9100, the microprocessor will automatically select between the Item List and the Logic Variables, depending on whether the connection is for an analog type or for a logic type.

**Logic Variable  
Tables**

**Table 64: Logic Variable Tables**

| Byte No.                            |     |              |    |  |    |          |   |  |  |
|-------------------------------------|-----|--------------|----|--|----|----------|---|--|--|
| Hex                                 | Dec | Tag          |    | Description                                    |    |          |   |  |  |
| 00H                                 | 00  | System Clock |    |  |    |          |   |  |  |
|                                     |     | X8           | X7 | X6   | X5 | X2       | 0 |  |  |
|                                     |     | X2 = 1       |    | Clock  |    | 0.5 sec. |   |  |  |
|                                     |     | X3 = 1       |    | Clock  |    | 1 sec.   |   |  |  |
|                                     |     | X4 = 1       |    | Clock  |    | 2 sec.   |   |  |  |
|                                     |     | X5 = 1       |    | Clock  |    | 4 sec.   |   |  |  |
|                                     |     | X6 = 1       |    | Clock  |    | 8 sec.   |   |  |  |
|                                     |     | X7 = 1       |    | Clock  |    | 16 sec.  |   |  |  |
|                                     |     | X8 = 1       |    | Clock  |    | 32 sec.  |   |  |  |
| 01H                                 | 01  | MNT          |    | Maintenance Control                            |    |          |   |  |  |
| 02H                                 | 02  | DIAG         |    | Diagnostic LOW BYTE                            |    |          |   |  |  |
| 03H                                 | 03  | DIAG         |    | Diagnostic HIGH BYTE                           |    |          |   |  |  |
| 04H                                 | 04  | DICT         |    | Digital Input Counters                         |    |          |   |  |  |
| 05H                                 | 05  | TOS          |    | TRIAC Output Status                            |    |          |   |  |  |
| 06H                                 | 06  | DIS          |    | Digital Input Status                           |    |          |   |  |  |
| 07H                                 | 07  | AIS          |    | Analog Input Status LOW BYTE                   |    |          |   |  |  |
| 08H                                 | 08  | AIS          |    | Analog Input Status HIGH BYTE                  |    |          |   |  |  |
| 09H                                 | 09  | LRST1        |    | Logic Results LOW BYTE                         |    |          |   |  |  |
| 0AH                                 | 10  | LRST1        |    | Logic Results HIGH BYTE                        |    |          |   |  |  |
| 0BH                                 | 11  | LRST2        |    | Logic Results LOW BYTE                         |    |          |   |  |  |
| 0CH                                 | 12  | LRST2        |    | Logic Results HIGH BYTE                        |    |          |   |  |  |
| 0DH                                 | 13  | LCOS1        |    | Logic Constants LOW BYTE                       |    |          |   |  |  |
| 0EH                                 | 14  | LCOS1        |    | Logic Constants HIGH BYTE                      |    |          |   |  |  |
| 10H                                 | 15  | LCOS2        |    | Logic Constants LOW BYTE                       |    |          |   |  |  |
| 10H                                 | 16  | LCOS2        |    | Logic Constants HIGH BYTE                      |    |          |   |  |  |
| 11H                                 | 17  | SUP          |    | Supervisory Control LOW BYTE                   |    |          |   |  |  |
| 12H                                 | 18  | SUP          |    | Supervisory Control HIGH BYTE                  |    |          |   |  |  |
| 13H                                 | 19  | LRST3        |    | Logic Results LOW BYTE (Version 1.1 or Later)  |    |          |   |  |  |
| 14H                                 | 20  | LRST3        |    | Logic Results HIGH BYTE (Version 1.1 or Later) |    |          |   |  |  |
| 15H                                 | 21  | LRST4        |    | Logic Results LOW BYTE (Version 1.1 or Later)  |    |          |   |  |  |
| 16H                                 | 22  | LRST4        |    | Logic Results HIGH BYTE (Version 1.1 or Later) |    |          |   |  |  |
| 17H                                 | 23  | Spare        |    |  |    |          |   |  |  |
| <b>Continued on next page . . .</b> |     |              |    |  |    |          |   |  |  |



| Byte No.<br>(Cont.)                 |     |        |                  |                                |
|-------------------------------------|-----|--------|------------------|--------------------------------|
| Hex                                 | Dec | Tag    | Description      |                                |
| 18H                                 | 24  | PM1HDC | Hold Control     | Programmable Function Module 1 |
| 19H                                 | 25  | PM1DO  | Logic Outputs    | Programmable Function Module 1 |
| 1AH                                 | 26  | PM1ST  | Status LOW BYTE  | Programmable Function Module 1 |
| 1BH                                 | 27  | PM1ST  | Status HIGH BYTE | Programmable Function Module 1 |
| 1CH                                 | 28  | PM2HDC | Hold Control     | Programmable Function Module 2 |
| 1DH                                 | 29  | PM2DO  | Logic Outputs    | Programmable Function Module 2 |
| 1EH                                 | 30  | PM2ST  | Status LOW BYTE  | Programmable Function Module 2 |
| 1FH                                 | 31  | PM2ST  | Status HIGH BYTE | Programmable Function Module 2 |
| 20H                                 | 32  | PM3HDC | Hold Control     | Programmable Function Module 3 |
| 21H                                 | 33  | PM3DO  | Logic Outputs    | Programmable Function Module 3 |
| 22H                                 | 34  | PM3ST  | Status LOW BYTE  | Programmable Function Module 3 |
| 23H                                 | 35  | PM3ST  | Status HIGH BYTE | Programmable Function Module 3 |
| 24H                                 | 36  | PM4HDC | Hold Control     | Programmable Function Module 4 |
| 25H                                 | 37  | PM4DO  | Logic Outputs    | Programmable Function Module 4 |
| 26H                                 | 38  | PM4ST  | Status LOW BYTE  | Programmable Function Module 4 |
| 27H                                 | 39  | PM4ST  | Status HIGH BYTE | Programmable Function Module 4 |
| 28H                                 | 40  | PM5HDC | Hold Control     | Programmable Function Module 5 |
| 29H                                 | 41  | PM5DO  | Logic Outputs    | Programmable Function Module 5 |
| 2AH                                 | 42  | PM5ST  | Status LOW BYTE  | Programmable Function Module 5 |
| 2BH                                 | 43  | PM5ST  | Status HIGH BYTE | Programmable Function Module 5 |
| 2CH                                 | 44  | PM6HDC | Hold Control     | Programmable Function Module 6 |
| 2DH                                 | 45  | PM6DO  | Logic Outputs    | Programmable Function Module 6 |
| 2EH                                 | 46  | PM6ST  | Status LOW BYTE  | Programmable Function Module 6 |
| 2FH                                 | 47  | PM6ST  | Status HIGH BYTE | Programmable Function Module 6 |
| <b>Continued on next page . . .</b> |     |        |                  |                                |

| Byte No.<br>(Cont.)                 |     |         |                  |                                 |
|-------------------------------------|-----|---------|------------------|---------------------------------|
| Hex                                 | Dec | Tag     | Description      |                                 |
| 30H                                 | 48  | PM7HDC  | Hold Control     | Programmable Function Module 7  |
| 31H                                 | 49  | PM7DO   | Logic Outputs    | Programmable Function Module 7  |
| 32H                                 | 50  | PM7ST   | Status LOW BYTE  | Programmable Function Module 7  |
| 33H                                 | 51  | PM7ST   | Status HIGH BYTE | Programmable Function Module 7  |
| 34H                                 | 52  | PM8HDC  | Hold Control     | Programmable Function Module 8  |
| 35H                                 | 53  | PM8DO   | Logic Outputs    | Programmable Function Module 8  |
| 36H                                 | 54  | PM8ST   | Status LOW BYTE  | Programmable Function Module 8  |
| 37H                                 | 55  | PM8ST   | Status HIGH BYTE | Programmable Function Module 8  |
| 38H                                 | 56  | PM9HDC  | Hold Control     | Programmable Function Module 9  |
| 39H                                 | 57  | PM9DO   | Logic Outputs    | Programmable Function Module 9  |
| 3AH                                 | 58  | PM9ST   | Status LOW BYTE  | Programmable Function Module 9  |
| 3BH                                 | 59  | PM9ST   | Status HIGH BYTE | Programmable Function Module 9  |
| 3CH                                 | 60  | PM10HDC | Hold Control     | Programmable Function Module 10 |
| 3DH                                 | 61  | PM10DO  | Logic Outputs    | Programmable Function Module 10 |
| 3EH                                 | 62  | PM10ST  | Status LOW BYTE  | Programmable Function Module 10 |
| 3FH                                 | 63  | PM10ST  | Status HIGH BYTE | Programmable Function Module 10 |
| 40H                                 | 64  | PM11HDC | Hold Control     | Programmable Function Module 11 |
| 41H                                 | 65  | PM11DO  | Logic Outputs    | Programmable Function Module 11 |
| 42H                                 | 66  | PM11ST  | Status LOW BYTE  | Programmable Function Module 11 |
| 43H                                 | 67  | PM11ST  | Status HIGH BYTE | Programmable Function Module 11 |
| <b>Continued on next page . . .</b> |     |         |                  |                                 |

| Byte No.<br>(Cont.)                 |     |         |                                     |                                 |
|-------------------------------------|-----|---------|-------------------------------------|---------------------------------|
| Hex                                 | Dec | Tag     | Description                         |                                 |
| 44H                                 | 68  | PM12HDC | Hold Control                        | Programmable Function Module 12 |
| 45H                                 | 69  | PM12DO  | Logic Outputs                       | Programmable Function Module 12 |
| 46H                                 | 70  | PM12ST  | Status LOW BYTE                     | Programmable Function Module 12 |
| 47H                                 | 71  | PM12ST  | Status HIGH BYTE                    | Programmable Function Module 12 |
| 48H                                 | 72  | AIST1   | Analog Input 1 Status               |                                 |
| 49H                                 | 73  | AIST2   | Analog Input 2 Status               |                                 |
| 4AH                                 | 74  | AIST3   | Analog Input 3 Status               |                                 |
| 4BH                                 | 75  | AIST4   | Analog Input 4 Status               |                                 |
| 4CH                                 | 76  | AIST5   | Analog Input 5 Status               |                                 |
| 4DH                                 | 77  | AIST6   | Analog Input 6 Status               |                                 |
| 4EH                                 | 78  | AIST7   | Analog Input 7 Status               |                                 |
| 4FH                                 | 79  | AIST8   | Analog Input 8 Status               |                                 |
| 50H                                 | 80  | AOC1    | Analog Output 1 Control and Status  |                                 |
| 51H                                 | 81  | AOC2    | Analog Output 2 Control and Status  |                                 |
| 52H                                 | 82  | DOC3    | Digital Output 3 Control and Status |                                 |
| 53H                                 | 83  | DOC4    | Digital Output 4 Control and Status |                                 |
| 54H                                 | 84  | DOC5    | Digital Output 5 Control and Status |                                 |
| 55H                                 | 85  | DOC6    | Digital Output 6 Control and Status |                                 |
| 56H                                 | 86  | DOC7    | Digital Output 7 Control and Status |                                 |
| 57H                                 | 87  | DOC8    | Digital Output 8 Control and Status |                                 |
| 58H                                 | 88  | XT1AIS  | Alarms LOW BYTE                     | - Extension Module 1            |
| 59H                                 | 89  | XT1AIS  | Alarms HIGH BYTE                    | - Extension Module 1            |
| 5AH                                 | 90  | XT1HDC  | Hold Control                        | - Extension Module 1            |
| 5BH                                 | 91  | XT1DO   | Output Control                      | - Extension Module 1            |
| 5CH                                 | 92  | XT1DI   | Input Status                        | - Extension Module 1            |
| 5DH                                 | 93  | XT1ST   | Error Status                        | - Extension Module 1            |
| 5EH                                 | 94  | XT2AIS  | Alarms LOW BYTE                     | - Extension Module 2            |
| 5FH                                 | 95  | XT2AIS  | Alarms HIGH BYTE                    | - Extension Module 2            |
| 60H                                 | 96  | XT2HDC  | Hold Control                        | - Extension Module 2            |
| 61H                                 | 97  | XT2DO   | Output Control                      | - Extension Module 2            |
| 62H                                 | 98  | XT2DI   | Input Status                        | - Extension Module 2            |
| 63H                                 | 99  | XT2ST   | Error Status                        | - Extension Module 2            |
| <b>Continued on next page . . .</b> |     |         |                                     |                                 |

| Byte No.<br>(Cont.)                 |     |        |                  |                      |
|-------------------------------------|-----|--------|------------------|----------------------|
| Hex                                 | Dec | Tag    | Description      |                      |
| 64H                                 | 100 | XT3AIS | Alarms LOW BYTE  | - Extension Module 3 |
| 65H                                 | 101 | XT3AIS | Alarms HIGH BYTE | - Extension Module 3 |
| 66H                                 | 102 | XT3HDC | Hold Control     | - Extension Module 3 |
| 67H                                 | 103 | XT3DO  | Output Control   | - Extension Module 3 |
| 68H                                 | 104 | XT3DI  | Input Status     | - Extension Module 3 |
| 69H                                 | 105 | XT3ST  | Error Status     | - Extension Module 3 |
| 6AH                                 | 106 | XT4AIS | Alarms LOW BYTE  | - Extension Module 4 |
| 6BH                                 | 107 | XT4AIS | Alarms HIGH BYTE | - Extension Module 4 |
| 6CH                                 | 108 | XT4HDC | Hold Control     | - Extension Module 4 |
| 6DH                                 | 109 | XT4DO  | Output Control   | - Extension Module 4 |
| 6EH                                 | 110 | XT4DI  | Input Status     | - Extension Module 4 |
| 6FH                                 | 111 | XT4ST  | Error Status     | - Extension Module 4 |
| 70H                                 | 112 | XT5AIS | Alarms LOW BYTE  | - Extension Module 5 |
| 71H                                 | 113 | XT5AIS | Alarms HIGH BYTE | - Extension Module 5 |
| 72H                                 | 114 | XT5HDC | Hold Control     | - Extension Module 5 |
| 73H                                 | 115 | XT5DO  | Output Control   | - Extension Module 5 |
| 74H                                 | 116 | XT5DI  | Input Status     | - Extension Module 5 |
| 75H                                 | 117 | XT5ST  | Error Status     | - Extension Module 5 |
| 76H                                 | 118 | XT6AIS | Alarms LOW BYTE  | - Extension Module 6 |
| 77H                                 | 119 | XT6AIS | Alarms HIGH BYTE | - Extension Module 6 |
| 78H                                 | 120 | XT6HDC | Hold Control     | - Extension Module 6 |
| 79H                                 | 121 | XT6DO  | Output Control   | - Extension Module 6 |
| 7AH                                 | 122 | XT6DI  | Input Status     | - Extension Module 6 |
| 7BH                                 | 123 | XT6ST  | Error Status     | - Extension Module 6 |
| 7CH                                 | 124 | XT7AIS | Alarms LOW BYTE  | - Extension Module 7 |
| 7DH                                 | 125 | XT7AIS | Alarms HIGH BYTE | - Extension Module 7 |
| 7EH                                 | 126 | XT7HDC | Hold Control     | - Extension Module 7 |
| 7FH                                 | 127 | XT7DO  | Output Control   | - Extension Module 7 |
| 80H                                 | 128 | XT7DI  | Input Status     | - Extension Module 7 |
| 81H                                 | 129 | XT7ST  | Error Status     | - Extension Module 7 |
| <b>Continued on next page . . .</b> |     |        |                  |                      |

| Byte No.<br>(Cont.)                 |     |        |                    |                        |
|-------------------------------------|-----|--------|--------------------|------------------------|
| Hex                                 | Dec | Tag    | Description        |                        |
| 82H                                 | 130 | XT8AIS | Alarms LOW BYTE    | - Extension Module 8   |
| 83H                                 | 131 | XT8AIS | Alarms HIGH BYTE   | - Extension Module 8   |
| 84H                                 | 132 | XT8HDC | Hold Control       | - Extension Module 8   |
| 85H                                 | 133 | XT8DO  | Output Control     | - Extension Module 8   |
| 86H                                 | 134 | XT8DI  | Input Status       | - Extension Module 8   |
| 87H                                 | 135 | XT8ST  | Error Status       | - Extension Module 8   |
| 88H                                 | 136 | TS1STA | Status and Control | - Time Schedule 1      |
| 89H                                 | 137 | TS2STA | Status and Control | - Time Schedule 2      |
| 8AH                                 | 138 | TS3STA | Status and Control | - Time Schedule 3      |
| 8BH                                 | 139 | TS4STA | Status and Control | - Time Schedule 4      |
| 8CH                                 | 140 | TS5STA | Status and Control | - Time Schedule 5      |
| 8DH                                 | 141 | TS6STA | Status and Control | - Time Schedule 6      |
| 8EH                                 | 142 | TS7STA | Status and Control | - Time Schedule 7      |
| 8FH                                 | 143 | TS8STA | Status and Control | - Time Schedule 8      |
| 90H                                 | 144 | OS1STA | Status and Control | - Optimal Start/Stop 1 |
| 91H                                 | 145 | OS2STA | Status and Control | - Optimal Start/Stop 2 |
| 92H                                 | 146 | AOC9   | Status and Control | - Analog Output 9      |
| 93H                                 | 147 | AOC10  | Status and Control | - Analog Output 10     |
| 94H                                 | 148 | AOC11  | Status and Control | - Analog Output 11     |
| 95H                                 | 149 | AOC12  | Status and Control | - Analog Output 12     |
| 96H                                 | 150 | AOC13  | Status and Control | - Analog Output 13     |
| 97H                                 | 151 | AOC14  | Status and Control | - Analog Output 14     |
| <b>Continued on next page . . .</b> |     |        |                    |                        |

| Byte No.<br>(Cont.) |     |        |                         |  |
|---------------------|-----|--------|-------------------------|--|
| Hex                 | Dec | Tag    | Description             |  |
| 98H                 | 152 | NDI1   | LOW BYTE                | Network Digital Input Module 1               |
| 99H                 | 153 | NDI1   | HIGH BYTE               | Network Digital Input Module 1               |
| 9AH                 | 154 | NDI2   | LOW BYTE                | Network Digital Input Module 2               |
| 9BH                 | 155 | NDI2   | HIGH BYTE               | Network Digital Input Module 2               |
| 9CH                 | 156 | NDI3   | LOW BYTE                | Network Digital Input Module 3               |
| 9DH                 | 157 | NDI3   | HIGH BYTE               | Network Digital Input Module 3               |
| 9EH                 | 158 | NDI4   | LOW BYTE                | Network Digital Input Module 4               |
| 9FH                 | 159 | NDI4   | HIGH BYTE               | Network Digital Input Module 4               |
| A0H                 | 160 | NDI5   | LOW BYTE                | Network Digital Input Module 5               |
| A1H                 | 161 | NDI5   | HIGH BYTE               | Network Digital Input Module 5               |
| A2H                 | 162 | NDI6   | LOW BYTE                | Network Digital Input Module 6               |
| A3H                 | 163 | NDI6   | HIGH BYTE               | Network Digital Input Module 6               |
| A4H                 | 164 | NDI7   | LOW BYTE                | Network Digital Input Module 7               |
| A5H                 | 165 | NDI7   | HIGH BYTE               | Network Digital Input Module 7               |
| A6H                 | 166 | NDI8   | LOW BYTE                | Network Digital Input Module 8               |
| A7H                 | 167 | NDI8   | HIGH BYTE               | Network Digital Input Module 8               |
| A8H                 | 168 | NDISTA | LOW BYTE                | Network Digital Input Reliability Status     |
| A9H                 | 169 | NDISTA | HIGH BYTE<br>(not used) | Network Digital Input Reliability Status     |
| AAH                 | 170 | NAISTA | LOW BYTE                | Network Analog Input Reliability Status      |
| ABH                 | 171 | NAISTA | HIGH BYTE               | Network Analog Input Reliability Status      |
| ACH                 | 172 |        |                         |  |
| to                  |     |        |                         |  |
| AFH                 | 175 | •      |                         | Spare for future expansion                   |
| B0H                 | 176 |        |                         |  |
| to                  |     |        |                         |  |
| BFH                 | 191 | •      |                         | Spare for future expansion                   |
| C0H                 | 192 |        |                         |  |
| to                  |     |        |                         |  |
| FFH                 | 255 | •      |                         | Local Variables used for PLC partial results |

# Appendix E: Analog Items and Logic Variables for the Trend Log Module

**Table 65: Analog Items and Logic Variables**

| For Point History  | For DX LCD Display   |
|--|--|
| <p><b>DX Versions 1.4, 2.3, and Later:</b></p> <p><b>Analog Items:</b><br/>           AI1 to AI8<br/>           OUT1 to OUT8<br/>           ACO1 to ACO8<br/>           XtnAI1 to XtnAI8*<br/>           XtnAO1 to XtnAO8*</p> <p><b>Logic Variables:</b><br/>           DIS (DI1..8)<br/>           LRST1 Low Byte (LRS1..8)<br/>           LRST1 High Byte (LRS9..16)<br/>           LRST2 Low Byte (LRS17..24)<br/>           LRST2 High Byte (LRS25..32)<br/>           XtnDI (XtnDI1..8)*</p> | <p><b>DX Versions 2.3, 3.3, and Later:</b></p> <p><b>Analog Items:</b><br/>           AI1 to AI8<br/>           OUT1 to OUT14<br/>           ACO1 to ACO8<br/>           XTnAI1 to XTnAI8<br/>           XTnAO1 to XTnAO8<br/>           PMnK1 to PMnK34<br/>           PMnOU1 to PMnOU8<br/>           PMnAX1, PMnAX2</p> <p><b>Logic Variables:</b><br/>           DIS (DI1..8)<br/>           LRST1 Low Byte (LRS1..8)<br/>           LRST1 High Byte (LRS9..16)<br/>           LRST2 Low Byte (LRS17..24)<br/>           LRST2 High Byte (LRS25..32)<br/>           LRST3 Low Byte (LRS33..40)<br/>           LRST3 High Byte (LRS41..48)<br/>           LRST4 Low Byte (LRS49..56)<br/>           LRST4 High Byte (LRS57..64)<br/>           TOS (DO3..8)<br/>           LCOS1 Low Byte (DCO1..8)<br/>           LCOS1 High Byte (DCO9..16)<br/>           LCOS2 Low Byte (DCO17..24)<br/>           LCOS2 High Byte (DCO25..32)<br/>           XTnDI (XTnDI1..8)<br/>           XTnDO (XTnDO1..8)<br/>           AIS Low Byte (AIH/L1..4)<br/>           AIS High Byte (AIH/L5..8)<br/>           XTnAIS Low Byte (XTnAIH/L1..4)<br/>           XTnAIS High Byte (XTnAIH/L5..8)<br/>           PMnDO (PMnDO1..8)</p> |
| * Available in Metasys Release 11.00.  |  |
| <b>Continued on next page . . .</b>  |  |

| For Point History (Cont.)  | For DX LCD Display  |
|--|---|
| <p><b>DX Version 2.3 and later only:</b></p> <p><b>Analog Items:</b><br/>OUT9 to OUT14</p> | <p><b>DX Version 3.3 and later only:</b></p> <p><b>Analog Items:</b><br/>NAI1 to NAI16</p> <p><b>Logic Variables:</b><br/>           NDI1 Low Byte (NDI1-1..8)<br/>           NDI1 High Byte (NDI1-9..16)<br/>           NDI2 Low Byte (NDI2-1..8)<br/>           NDI2 High Byte (NDI2-9..16)<br/>           NDI3 Low Byte (NDI3-1..8)<br/>           NDI3 High Byte (NDI3-9..16)<br/>           NDI4 Low Byte (NDI4-1..8)<br/>           NDI4 High Byte (NDI4-9..16)<br/>           NDI5 Low Byte (NDI5-1..8)<br/>           NDI5 High Byte (NDI5-9..16)<br/>           NDI6 Low Byte (NDI6-1..8)<br/>           NDI6 High Byte (NDI6-9..16)<br/>           NDI7 Low Byte (NDI7-1..8)<br/>           NDI7 High Byte (NDI7-9..16)<br/>           NDI8 Low Byte (NDI8-1..8)<br/>           NDI8 High Byte (NDI8-9..16)</p> |

Note: Since a logic variable byte is recorded when any one of its variables changes state, you are recommended to assign LRS logic variable bytes to trend log and to connect the source variables (the ones that you wish to trend) to the individual LRS variables in a PLC module.



**Controls Group**  
 507 E. Michigan Street  
 P.O. Box 423  
 Milwaukee, WI 53201

[www.johnsoncontrols.com](http://www.johnsoncontrols.com)  
 Printed in U.S.A.