



GE Lighting Controls

INSTALLATION INSTRUCTIONS

Model #

CIR-05-360-D
CIR-15-360-D



Passive Infrared Ceiling Low Voltage Occupancy Sensor

General Information

- Read all instructions on both sides of this sheet first.
- Plan all component locations carefully.
- For indoor use only.
- Install in accordance with ALL local codes.
- For use with GE switchpacks and systems only. For use with other systems contact technical support.
- Do not run Low Voltage wiring in the same conduit as power conductors.

Specifications

Technology: Passive Infrared (PIR)

Time Delays: Self-Adjusting from 10 min. to 30 min.

Electrical Ratings:

- Input**
- 10-30VDC from GE Switchpack or GE System. Maximum current needed is 25mA per sensor.
- Output**
- Open collector output to switch up to ten GE Switchpacks.
 - Isolated Form C Relay
 - Isolated Form C Relay Ratings: 1A 30VDC/VAC

Housing:

- Medium impact injection molded housing. ABS resin complies with UL 94V0. Paintable off-white.

Size:

- 4.7" diameter, 1.5" deep (119.4mm x 38.1mm)

Daylight sensor:

- 10 fc - 150 fc userselectable

LED Indicators: Red LED indicates PIR detection.

Operating Environment:

- Temperature: 60° F - 80° F (15° C - 26° C)
- Relative Humidity: up to 95% non-condensing
- For indoor use only

Description

GE Passive Infrared ceiling sensors can be used individually or in combination to provide lighting control and integration with HVAC control throughout a building.

The technology contained within sensor continuously self-adjusts sensitivity and time-delay automatically and immediately in response to occupant behavior. There is no need for time consuming manual adjustments or to "learn" behavior patterns over extensive periods of time.

Model	Coverage	Field of View
CIR-05-360-D	Up to 450 sq. ft.	360°
CIR-15-360-D	Up to 1200 sq. ft.	360°

Coverage

Major Minor

CIR-05-360-D

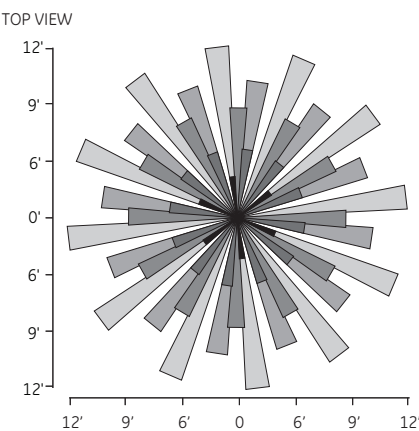

CIR-15-360-D

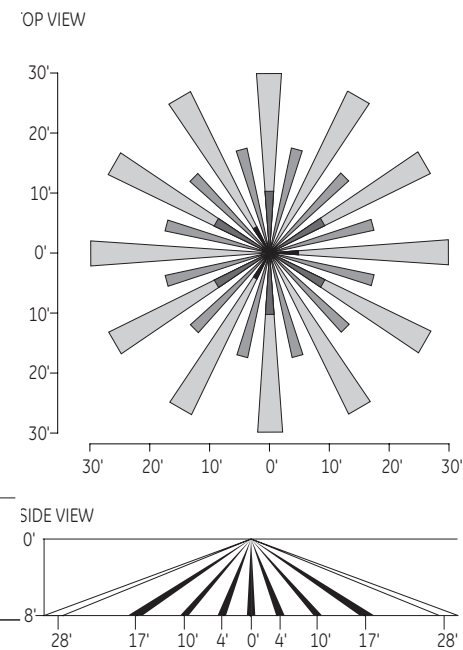

Location

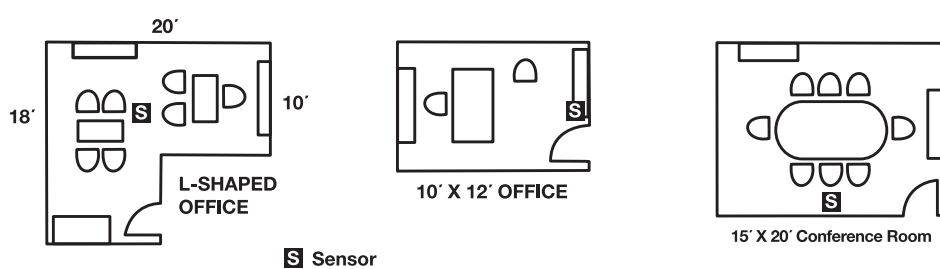

Installation

NOTE: Before you begin, read these instructions completely and carefully.



Sensor:

Choose sensor location carefully. The sensor must have a clear view of the area to be controlled. It should not be blocked from "seeing" people by high partitions. The sensor will not "see" through glass. Mounting height should be kept below 12 feet. Avoid pointing into hallways. To prevent false activation, the sensor should be mounted at least six feet away from the path of strong air turbulence. For typical placement, refer to Location Diagrams. For indoor use only.

Coverage shown is for areas with no partitions or with partitions which do not exceed 48 inches in height.

Switchpack:

The switchpack is generally mounted above the ceiling on the outside of the junction box that contains a hot line, neutral and the existing switch leg from which the lighting is controlled. If additional switchpacks are required, they are mounted on the outside of the boxes containing the appropriate switch legs. In installations where there are no existing switch legs, the switchpack may be mounted on the outside of any conventional standard junction box, with or without an extension ring.

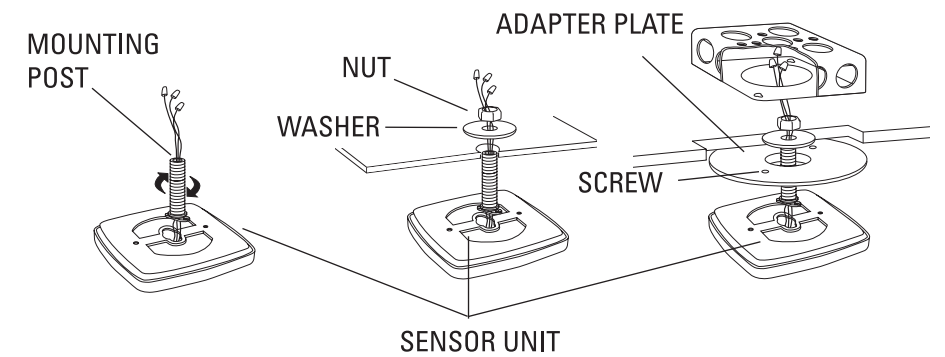
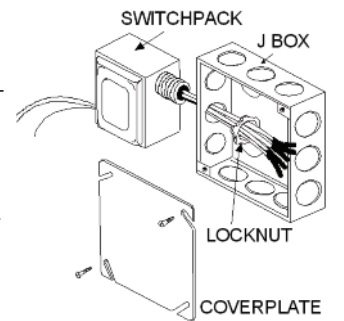

Wiring

CAUTION: Before installing or performing any service on a GE system, the power MUST be turned off at the branch circuit breaker. According to NEC 240-83(d), if the branch circuit breaker is used as the main switch for a fluorescent lighting circuit, the circuit breaker should be marked "SWD." All installations should be in compliance with the National Electric Code and all state and local codes.

NOTE REGARDING COMPACT FLUORESCENT LAMPS: The life of some compact fluorescent lamps (CFLs) is shortened by frequent automatic or manual switching. Check with CFL and ballast manufacturer to determine the effects of cycling.

Sensor:

1. Pass wires through the threaded mounting post and interlock to the backplate.
2. The sensor mounts to normal ceiling tile through a single 3/4" hole.
3. When mounted, the sensor's slotted grills must point along the path where motion is to be detected.
4. An adapter plate (CPLATE) is available to allow mounting to a standard fixture ring and junction box.
5. The threaded mounting post may be cut down if it is too long to fit into the junction box.

CAUTION: Finger-tighten the nut to avoid stripping the mounting post. (Checkout and Adjustments section)

Switchpack:

Designed to be mounted externally to any junction box. When mounted, line connections are inside the box and the Class 2 wiring exits through the rear of the switchpack housing. In areas where Class 2 wiring is not permitted, the switchpack can be mounted internally to any standard electrical box.

Wiring Diagram 1: One switchpack, one sensor - occupancy control with manual switch option

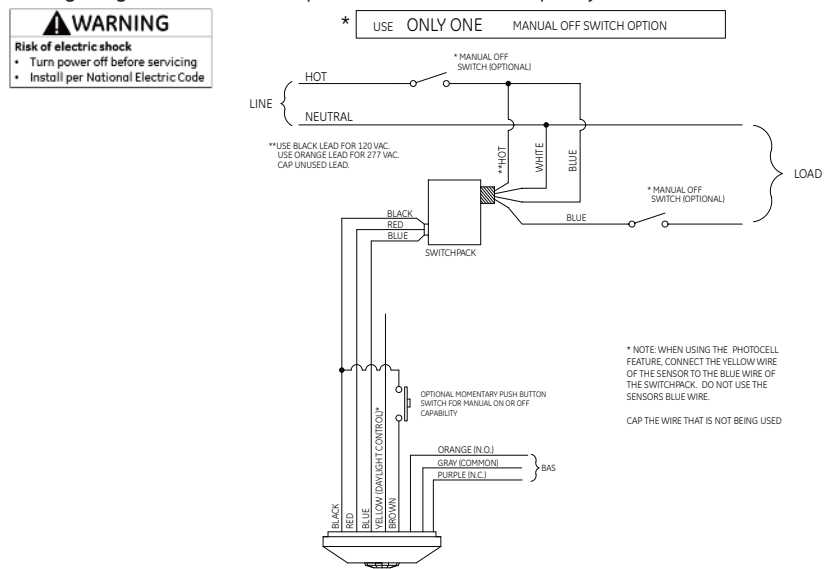

Wiring Diagram 2: One sensor, multiple switchpacks - one occupancy control, one daylight control

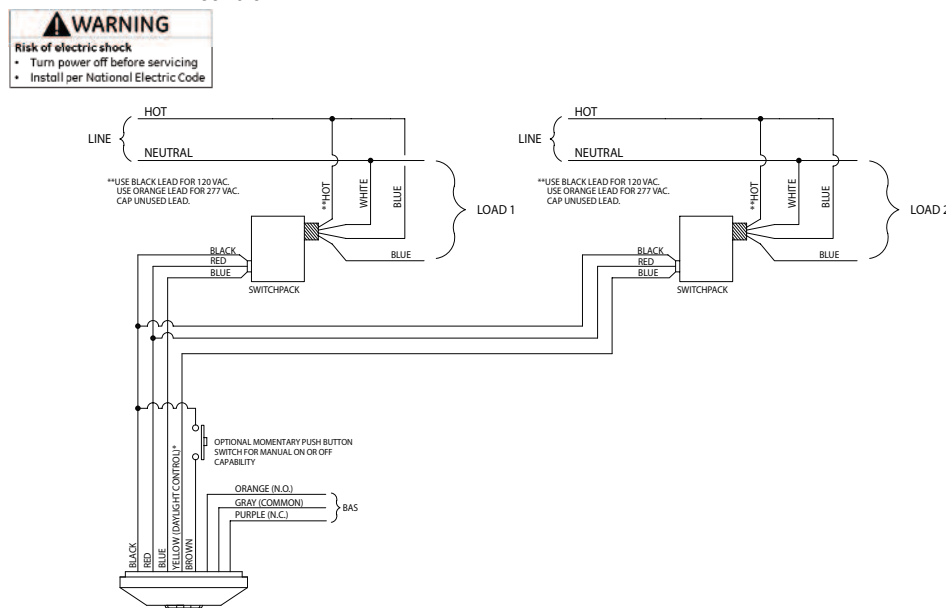

Wiring Diagram 3: One sensor, two switchpacks - occupancy control

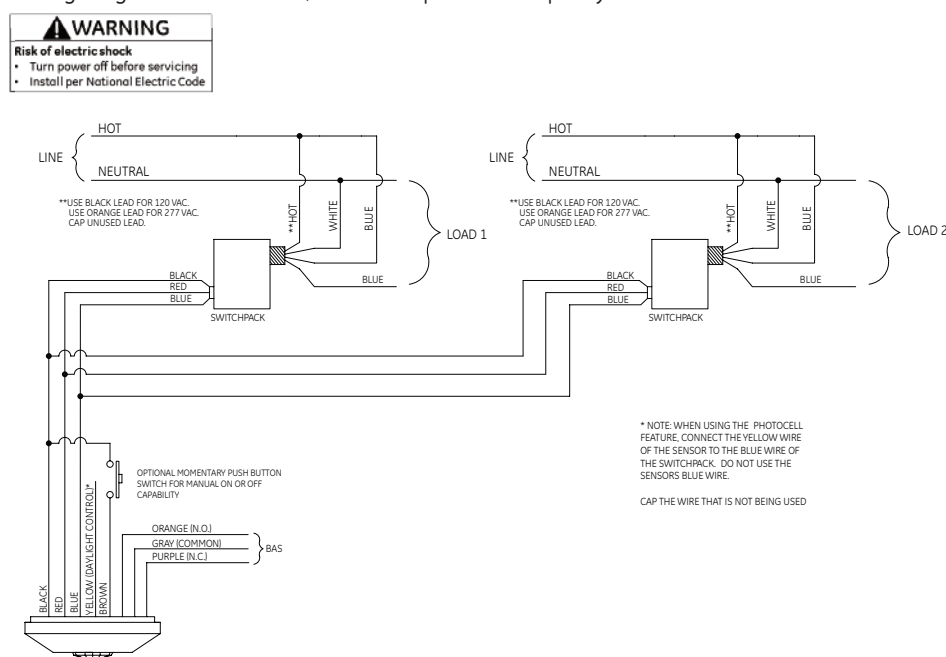

Checkout and Adjustment

Sensor Adjustments:

No manual adjustments necessary at installation. The sensor will automatically set the time delay to the recommended setting of 10 minutes when left at the installer test setting after lights are off for a minimum period of 5 minutes. At installation, the sensor will scan the coverage area to determine the optimum sensitivity setting. GE PIR Ceiling Sensors continually self-adjust sensitivity and time-delay automatically and immediately in response to occupant behavior, eliminating the need to "learn" behavior patterns over time. This reduces the need for follow-up adjustments. DIP switch override allows time delay to be locked at 30 minutes.

Lighting Sweep:

When sensors are used in conjunction with computer lighting sweep systems, you MUST enable the Lighting Sweep feature by turning DIP-switch 2 to position 2. Enabling this feature prevents an unnecessary "lights on" following the computer power-on sweep.

Daylight Full Logic/Half Logic:

In both Full Logic mode and Half Logic mode, lights connected to the yellow control lead will not turn-on upon occupancy activation, should the ambient light level exceed the preset foot-candle level.

After Activation:

Full Logic mode- should the ambient light level exceed the preset foot-candle level, the lights connected to the yellow control lead will turn-off. The lights will remain off, until the ambient light level falls below the set point.

Half Logic mode- the output state of the yellow control lead will not change with ambient light changes, after occupancy activation.

Testing the Sensor:

*Sensor automatically adjusts to the surrounding environment; thus testing the sensor is not required.

- 1: Flip dip switch 2 to position 2
- 2: Leave dip switch at position 2 for 1 second
- 3: Flip dip switch back to position 1

NOTE: Sensor is now in test mode. Sensor will remain in test mode as long as lights are not continuously off for 5 minutes. During the test mode, the time delay is 15 seconds.

4: Remain still. The LED will not flash. The lights should turn off after 15 seconds. (if not, see Troubleshooting.)

5: Move about the coverage area. The lights should come on.

Testing is now complete. Simply leave the area. Lights should turn off after 15 seconds. After 5 minutes of the lights being off, sensor will automatically go into user mode.

DIP Switch Settings

	1	2	3	4	5	6	7	8
	On Mode	Lighting Sweep	Time Delay	Override	Daylight Logic	Light Level A	Light Level B	Light Level C
Position 2	Manual On	Enabled	30 minutes	Override	Full Logic	Enabled	Enabled	Enabled
Position 1	Auto On	Not Enabled	Self Adjusting	Normal	Half Logic	Not Enabled	Not Enabled	Not Enabled

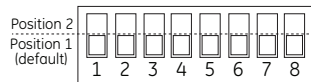

Light Level Settings			
	A	B	C
150 fc	↓	↓	↓
100 fc	↓	↓	↑
70 fc	↓	↑	↓
50 fc	↓	↑	↑
30 fc	↑	↓	↓
20 fc	↑	↓	↑
10 fc	↓	↓	↑
Not Enabled	↑	↑	↑

Troubleshooting

LED will not turn ON:

- Verify 10-30 VDC across the red and black wires of the sensor.
- Unless connected to a momentary switch for manual control, ensure that DIP switch 1 is in the default position.
- If there is no power at the sensor, check for 12-18 VDC at the switchpack output and 120 VAC or 277VAC at the switchpack input. Verify correct primary connections.
- If the voltage is OK at the switchpack, recheck all wiring and connections.
- If the LED still does not operate, please contact technical service.

Lights will not turn OFF:

- Confirm that no other switches or equipment are interrupting or bypassing power to the switchpack or load.
- Unless connected to a momentary switch for manual control, ensure that DIP switch 1 is in the default position.
- Short the blue and red switchpack control leads together to energize the relay.
- If the lights turn on, contact technical service.
- If the lights do not turn on, check wiring on the switchpack load side and check the switchpack contacts for continuity. Replace the switchpack if necessary.

Lights will not turn OFF:

In smaller rooms, the sensor may be activated by people moving in the hallway outside the room. Adjust the Sensitivity control toward minimum to prevent this or relocate the sensor. If the lights will not turn OFF after the time period set on the sensor, and the LED has not lit during the time period:

- Confirm that no other switches or equipment are interrupting or bypassing power to the switchpack or load.
- Make sure DIP switch 4 is in the default position, and the bypass switch is in the "Auto" position.

Note: If multiple sensors/switchpacks are installed, check one at a time.

Manual-On Override Switch:

The sensor has a built-in override switch on the printed circuit board designed to turn the load on in the event of sensor failure when the sensor can not be replaced immediately. The switchpack must be operative for this switch to work. If the switchpack is defective, it must be replaced or bypassed to activate the load. To operate this switch, remove the cover of the sensor and move the override switch from the "auto" position to the "on" position. All switchpacks connected to the sensor will now be energized. If multiple sensors control the same switchpack(s), activating the override switch on any one sensor will activate all of the switchpacks.

Sensor Cover Removal:

1. To remove the cover from the sensor unit, grasp the corners and pull down gently. Unit will snap open.
2. Locate the manual-on override switch and move to the "Auto" to "On" position. "Auto" position is towards the wire harness. "On" position is away from the wire harness.
3. To replace the cover, position controls to line up with the holes in the center of the cover. Unit will snap closed.

Technical Service: 1-877-584-2685

Limited Warranty

GE warrants that the product will be free from defects in material, workmanship, and title. This warranty applies only to defects that appear within five (5) years from the date of GE's invoice (except for defects in title, which shall have no time limitation). If the product fails to meet the above warranties and if Purchaser notifies GE in writing within thirty (30) days after discovery of the defect, then GE shall correct such defect by either (at GE's option) replacing the defective part or product (f.o.b. GE's plant or other point of shipment, with freight allowed to destinations within the continental United States, Alaska and Hawaii) or refunding the price. The foregoing warranties apply only to product purchased directly from GE, and do not apply to failures caused by acts of God or as a result of any improper installation, maintenance, storage or service, any accident, abuse, misuse, abnormal use, modification, misapplication, use in violation of any applicable standard or code, any failure attributable to any associated or complementary products not supplied by GE, or any failure to comply with any applicable recommendations of GE. GE reserves the right to examine the failed product to determine the cause of failure. THE FOREGOING WARRANTIES AND REMEDIES ARE EXCLUSIVE AND SHALL CONSTITUTE THE SOLE REMEDY OF PURCHASER AND THE SOLE LIABILITY OF GE WITH REGARD TO DEFECTS IN, OR FAILURE OF, THE PRODUCT WHETHER THE CLAIM IS IN CONTRACT, INDEMNITY, WARRANTY, TORT (INCLUDING NEGLIGENCE), STRICT LIABILITY OR OTHERWISE. GE MAKES NO OTHER WARRANTY, STATUTORY OR OTHERWISE, AND NONE IS TO BE IMPLIED. IN PARTICULAR, WITHOUT LIMITING THE FOREGOING, NO WARRANTY OF MERCHANTABILITY OR FITNESS FOR A PARTICULAR PURPOSE IS MADE OR IS TO BE IMPLIED.