

Dual Technology Corner/Wall Mounted Low Voltage Occupancy Sensor

General Information

- Read all instructions on both sides of this sheet first
- Install in accordance with ALL local codes.
- For indoor use only.
- For Use with GE Switchpacks & Systems Only.
- Do not run any GE Low Voltage Wiring in the same conduit as power conductors.

Specifications

Technology: Passive Infrared (PIR) and Ultrasonic (US)

Power Requirements:

Input:

- 10-30 VDC from GE Switchpack or GE system.
- Maximum current needed is 25mA per sensor

Output:

- Open collector output to switch up to ten GE Switchpacks. BAS with Isolated Form C Relay (-D model)
- Isolated Form C Relay Ratings: 1A 30VDC/VAC

Time Delays: Self-Adjusting, 15 seconds/test (10 min Auto), or Selectable 5, 15, 30 minutes

Coverage: 1200 sq. ft.

Light Level Sensing: 0 to 300 foot-candles (- R model)

Operating Environment:

- Temperature: 32° F – 104° F (0° C – 40° C)
- Relative Humidity: up to 90% non-condensing

Housing:

- Medium impact injection molded housing.
- Polycarbonate resin complies with UL94V0.

Size: 4.4" x 3.4" x 2" (112mm x 86.4mm x 50.8mm)

LED Indicators: Red indicates PIR detection; Green indicates Ultrasonic detection

Description

The SDT-WIDE Corner/Wall Mount Low Voltage Occupancy Sensor is a Passive Infrared (PIR) and Ultrasonic (US) motion sensing lighting control, used for energy savings and convenience. PIR is used to turn the lights ON and then either or both technologies are used to keep the lights ON. When motion is detected, the blue wire is electronically connected to the red wire, energizing the relay in the switchpack to turn on the load. If vacancy is detected, the blue wire is disconnected from the red, causing the relay to open turning off the load. The red lead is 10-30 VDC supply, the black lead is common, and the blue is the relay control.

The sensor includes self-adaptive technology that continually adjusts to conditions by adjusting sensitivity and time delay in real-time.

The Daylighting feature (-D model only) prevents lights from turning ON when the room is adequately illuminated by natural light.

Walk-Through feature maximizes energy savings by not leaving the lights ON after momentary occupancy. The sensor will switch the lights ON when it detects a person entering the area. If the sensor does not continue to detect motion 30 seconds following the initial activation, it will automatically go to a shorter 2 minute time delay.

In Automatic ON Mode, the lights turn ON when a person enters the room. In Manual On Mode, the lights are turned ON by activating a momentary switch (model # RS2-*) that is connected to the sensor. When used with 2 level lighting (-D model only), bi-level Automatic-on can be achieved which allows Zone 1 to come ON automatically upon occupancy. Zone 2 does not come ON unless the occupant presses the optional momentary switch.

Coverage

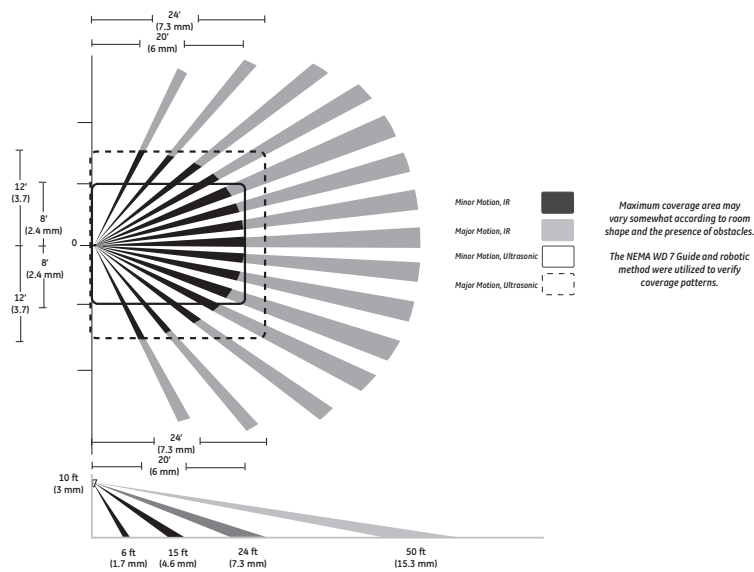

Location

The maximum coverage area may vary somewhat according to room shape and the presence of obstacles. Follow the coverage diagram concerning major and minor motion coverage. Decrease total coverage area by 15% for "soft" rooms (for example, heavy draperies or heavy carpeting). The sensor must have a clear view of the area to be controlled. The sensor will not "see" through glass. Mounting height should not exceed 12 feet. Optimum mounting height is 10 feet. Mount the sensor so the grilles face the open portion of the room and are not facing a nearby wall, door, window, or other obstructing object. Avoid pointing into hallways. **To prevent false activation, the sensor should be mounted away from the air supply duct a minimum of 4 to 6 feet.** Mounting at fixture height is most effective. For typical placement refer to Location Diagram.

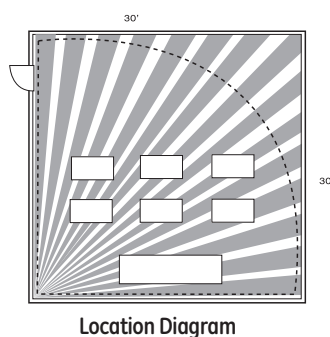

Installation

The SDT-WIDE can be mounted to the wall, ceiling, junction box, or round fixture with raceway.

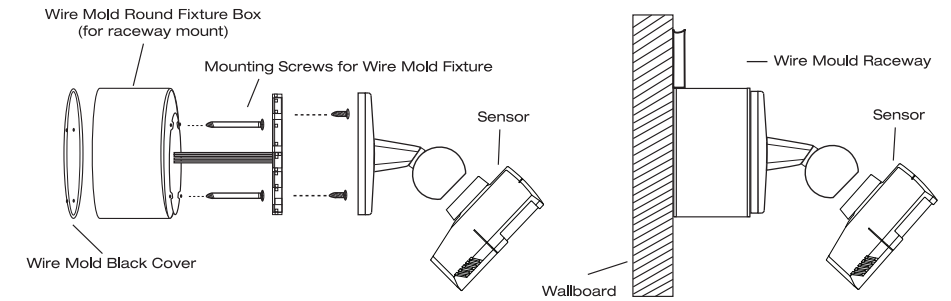
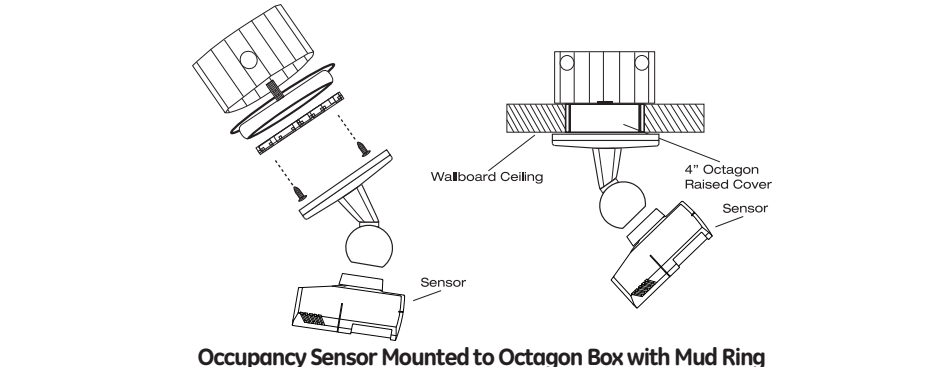
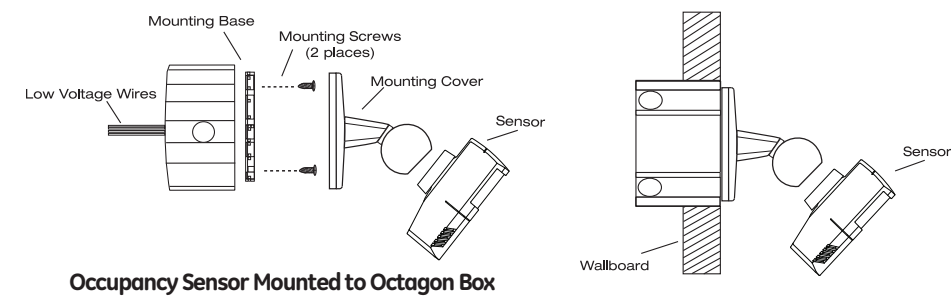
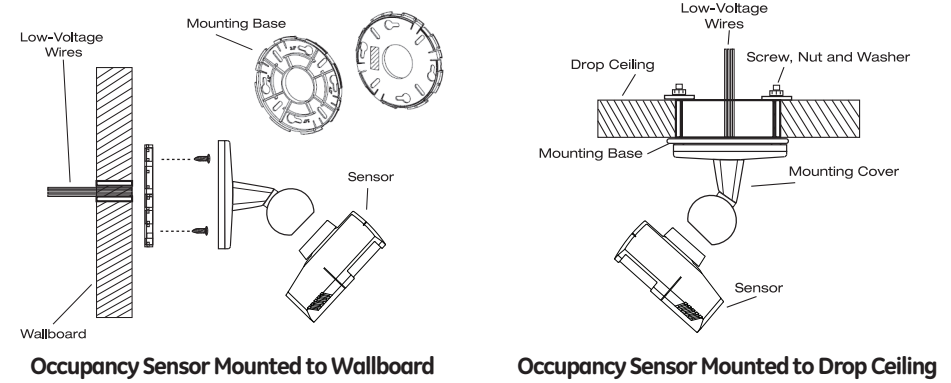

Wiring

CAUTION: Before installing or performing any service on a GE system, the power **MUST** be turned OFF at the branch circuit breaker. According to NEC 240-83(d), if the branch circuit breaker is used as the main switch for a fluorescent lighting circuit, the circuit breaker should be marked "SWD". All installations should be in compliance with the National Electric Code and all state and local codes.

NOTE REGARDING COMPACT FLUORESCENT LAMPS: The life of some compact fluorescent lamps (CFLs) is shortened by frequent automatic or manual switching. Check with CFL and ballast manufacturer to determine the effects of cycling.

1. Make sure power is turned OFF at the branch circuit breaker.
2. Wire units as shown in wiring diagrams per applicable voltage requirements. (Use twist-on wire connectors for all connections) **CAP ALL UNUSED WIRE LEADS.**
3. Mount unit to wall, ceiling, junction box, or round fixture with raceway.
4. Turn power back ON at the branch circuit breaker and wait 2 minutes for the unit to stabilize.
5. Make necessary adjustments. (See Checkout and Adjustments section)

One Sensor, One Switchpack

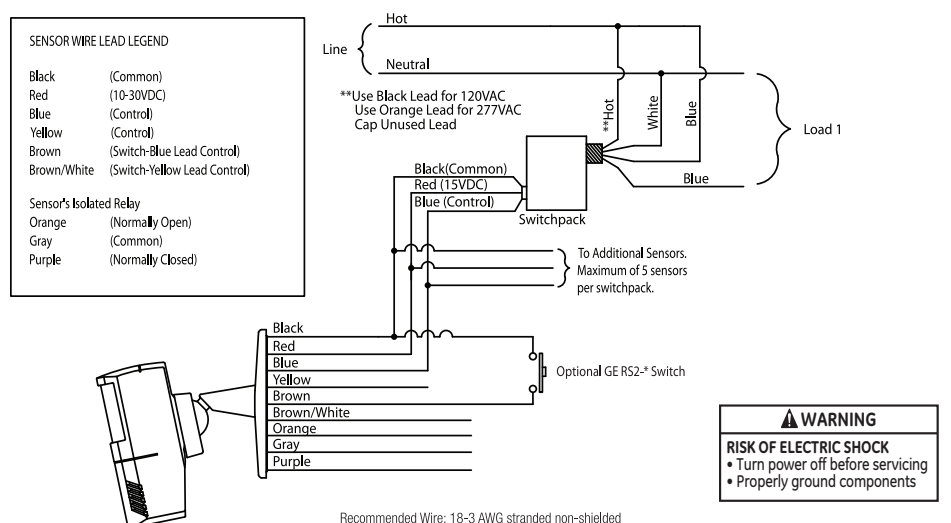

One Sensor, Multiple Switchpacks

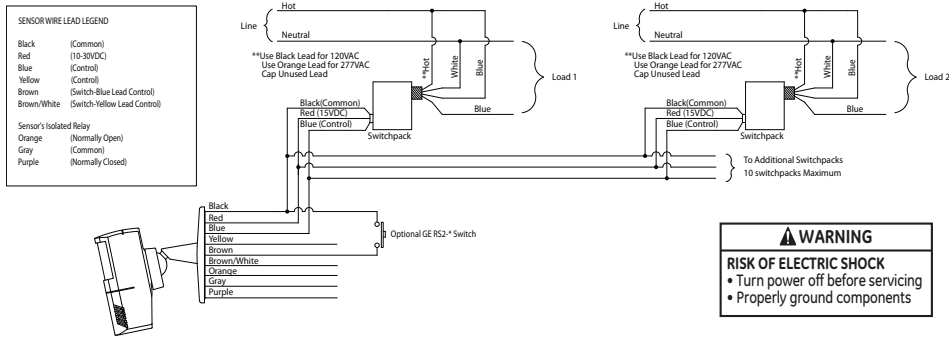

DIP Switch Settings

DIP Switch Legend

DIP Switch	Time Delay		Activation	Activation	PIR Sensitivity	Walk-Through Mode	LEDs	Override	Lighting Sweep	Daylighting Mode
	1	2	Power Pack One	Power Pack Two						
Auto*	▼	▼	Auto	Auto	Full	Disable	Enable	Disable	Disable	Half
5 Minutes	▼	▼	Manual	Manual	50%	Enable	Disable	Enable	Enable	Full
15 Minutes	▲	▲								
30 Minutes	▲	▲								

*Self-Adjusts to 10 min. user mode

Default =

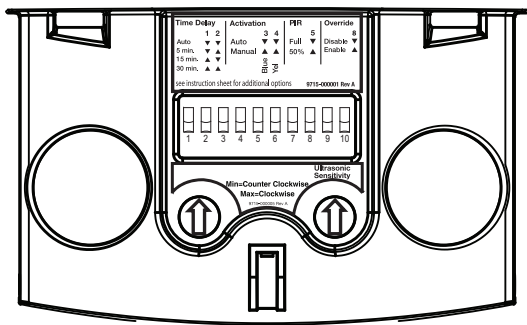

Checkout and Adjustment

Adjustments should be made with the HVAC system ON. Use only insulated tools to make adjustments.

Self-Adjust

Sensor is shipped in the Self-Adjust Mode. This applies to time delay, US, and PIR sensitivity. In preparation for the Installer Test, the time delay is set to 15 seconds, after the sensor is installed, powered-ON and has stabilized, the unit will time-out 15 seconds after the last motion detected. Coverage and sensitivity can be confirmed by watching the Green (US) and Red (PIR) indicator LEDs on the front of the sensor, while moving around the room.

- Walk around the room and monitor LEDs. LEDs should only turn ON for one second with each motion. (If LEDs do not turn ON, go to Installer Adjustments - Sensitivity Adjustments Section)
- Stand still six to eight feet away from the sensor for five seconds. LEDs should not turn ON. (If any LED turns ON, note LED and go to Installer Adjustments - Sensitivity Adjustment section)
- Walk outside the room and wait 15 seconds for the lights to turn OFF. (If lights do not turn OFF go to Installer Adjustments Section)
- Re-enter the room to activate sensor. (If lights do not turn ON go to Troubleshooting Section)
- The unit will remain in Test Mode for 5 minutes then automatically exit Test Mode and go for 10 min. Time Delay User Mode setting.

Note: To place into Test Mode, toggle DIP Switch 10 out of its current position, wait 3 seconds, and then back in to its original position. To force into 10 min User Mode move Dip Switches 1 and 2 down. (If DIP Switches 1 and 2 are already down, toggle DIP Switch 1 out of its current position, wait 3 seconds, and then back to its original position) While in Test Mode, the LEDs will flash once per 1/4 second.

Installer Adjustments

Sensitivity Adjustments

Ultrasonic Sensitivity (Green LED) - Using a small flathead screw driver turn the green potentiometer so that the arrow points UP.

- Stand in different areas of the room and wave your hands.
- If the Green LED does not turn ON, increase the US sensitivity by turning the green potentiometer clockwise in small increments. Repeat Step 1.
- Stand still six to eight feet away from sensor for five seconds. LED should not turn ON.
- If Green LED turns ON without motion or is constantly ON decrease the US sensitivity by turning the green potentiometer counter-clockwise in small decrements. Repeat Step 3.

PIR Sensitivity

- Stand in different areas of the room and wave your hands.
- If the Red LED does not turn ON, check for any obstructions.
- Stand still six to eight feet away from sensor for five seconds. LED should not turn ON.
- If Red LED turns ON without motion or is constantly ON adjust PIR sensitivity to 50% by moving DIP Switch 5 UP.

Field-of-view outside the space

- Adjust PIR sensitivity to 50% by moving DIP Switch 5 UP.
- Adjust Ultrasonic Sensitivity.

Daylight Adjustments (-D model only)

If this feature is not needed, leave the light level at maximum (fully clockwise).

The Daylighting feature prevents the lights from turning ON when the room is adequately illuminated by natural light. If there is enough light in the room regardless of occupancy, the sensor will hold the lights OFF. If there is not enough light in the room, the sensor will allow the lights to turn ON when occupied.

Full and Half Logic Modes (See DIP Switch legend):

In both Full and Half Logic modes, lights connected to the yellow control lead will not turn ON upon occupancy activation, should the ambient light level exceed the preset foot-candle level.

After activation:

Full Logic Mode - should the ambient light level exceed the preset foot-candle level, the lights connected to the yellow control lead will turn OFF. The lights will remain OFF, until the ambient light level falls below the set point.

Half Logic Mode - the output state of the yellow control lead will not change with ambient light changes, after occupancy activation. If the amount of natural light available rises above the setpoint, the daylight sensor will not turn the lights OFF while occupancy is being detected.

Note: Set the light level when the ambient light is at the level where no artificial light is needed. In order for this feature to function, the yellow control lead must be wired.

- With the load ON, put the sensor into Test Mode. To place into Test Mode, toggle DIP Switch 10 out of its current position, wait 3 seconds and then back in to its original position.
- Set DIP Switch 10 to Full or Half Logic Mode.
- Set the Light level to Minimum (fully CCW).
- Leave the room and let the sensor time-out so lights are OFF. Enter the space and lights should remain OFF.
- Make sure not to block the sensor from the daylight source and adjust the light level potentiometer CW in small increments until the lights are ON. (Pause 5 seconds between each adjustment)
- Once the lights are ON, the load connected to the sensor will not turn ON if light levels are above the current illumination.

Time Delay Adjustments

People who remain very still for long periods of time may need a longer Time Delay than the default setting of 10 minutes. As long as Auto is enabled, the sensor will respond to each pair of false offs with no normal off in between, by alternately making slight adjustments to either time delay (by 2 minute increments) or sensitivity, so there should be no need for manual adjustment. If manual adjustment is desired, refer to Time Delay settings in DIP Switch legend.

Reset sensor time delay to factory settings by moving DIP Switches 1 and 2 down. (If DIP Switches 1 and 2 are already down, toggle DIP Switch 1 out of its current position, wait 3 seconds, and then back to its original position)

Automatic Mode

In Automatic-ON Mode, the lights turn ON when a person enters the room. If optional momentary low voltage switches are used along with Automatic-ON Mode, activating the switch(es) while the load is ON turns the load OFF. When the load is turned OFF manually, as long as the sensor continues to detect occupancy the loads stay OFF. After the time delay expires, the lights stay OFF and the sensor goes back to Automatic-ON Mode. For wiring information for the optional momentary low voltage switch(es), please see the wiring section of the installation instructions.

Manual Mode

In Manual-ON Mode, the optional momentary low voltage switch(es) is required to turn the load(s) ON. Once activated the sensor will maintain the lights ON until motion ceases and the time delay expires. While the room is occupied the BAS relay remains active. After the time delay expires, the load(s) will automatically be turned OFF and the switch(es) must be used to turn the load(s) ON unless there is motion detected within the 10 second re-trigger period.

Lighting Sweep Option

If selected, this DIP Switch option forces an initial 60 second delay upon "power up" to prevent activation in buildings with computer control systems.

- Move DIP Switch 9 UP.

Override

The Override setting allows the lights to remain ON in the unlikely event of sensor failure.

- Move DIP Switch 8 UP.

While in Override Mode, the optional low voltage momentary switch(es) will toggle the lighting load(s).

Troubleshooting

Issue	Possible Causes	Suggestions
Lights Will Not Turn ON automatically	Wall Switch OFF	Turn Wall Switch ON.
	If low voltage switch option is used, lights may have been turned-off manually.	Press low-voltage switch.
	Daylight Feature Enabled	If all lights are required to turn ON adjust DIP Switch 10 and/or daylight potentiometer
Lights Will Not Turn ON manually	Power interruption	Check incoming voltage and/or wiring
	Daylight Feature Enabled	If all lights are required adjust DIP switch 10 and/or daylight potentiometer.
	Power interruption	Check incoming voltage and/or wiring
If lights will still not turn ON, set sensor to override mode and call Technical Services at 1-877-584-2685		
Lights Will Not Turn OFF automatically	Override	Make sure sensor is not in Override Mode (DIP Switch 8 up).
	Ultrasonic Sensitivity set High	Lower sensitivity by turning green potentiometer CCW in small decrements.
	Sensor installed close to an air vent	Sensors should be installed minimum 4 - 6 feet away from any air vent and out of path of heavy airflow.
	Sensor installed close to indirect lighting.	Sensors should be mounted away from indirect lighting.
	Self-adjust	It may be possible for the unit to have self-adjusted the time delay to a 30 minute delay. If the lights do not turn OFF after 30 minutes follow next step.
	30 Minute Delay	Maximum time delay is 30 Minutes. Check DIP Switches to verify DIP Switch settings. If lights do not turn OFF at the set time delay, check next step.
Lights Will Not Turn OFF manually	PIR activated by heat source other than occupant	Move DIP Switch 5 up.
	Bypass	Check wiring to make sure sensor or switchpack are not bypassed.
	Override	Make sure sensor is not in Override Mode (DIP Switch 8 up).
If lights will still not turn OFF, call Technical Services at 1-877-584-2685		

Limited Warranty

This product is warranted to be free from defects in material and workmanship and shall conform to and perform in accordance with Seller's written specifications for a period of five (5) years from date of shipment for all occupancy sensors. We guarantee the performance of our product to specifications or your money back. This warranty will be limited to the repair or replacement, at Seller's discretion, of any such goods found to be defective, upon their authorized return to Seller. This limited warranty does not apply if the goods have been damaged by accident, abuse, misuse, modification or misapplication, by damage during shipment or by improper service. There are no warranties, which extend beyond the hereinabove-limited warranty, INCLUDING, BUT NOT LIMITED TO, THE IMPLIED WARRANTY OF MERCHANTABILITY AND THE IMPLIED WARRANTY OF FITNESS. No employee, agent, dealer, or other person is authorized to give any warranties on behalf of the Seller or to assume for the Seller any other liability in connection with any of its goods except in writing and signed by the Seller. The Seller makes no representation that the goods comply with any present or future federal, state or local regulation or ordinance. Compliance is the Buyer's responsibility. The use of the Seller's goods should be in accordance with the provision of the National Electrical Code, UL and/or other industry or military standards that are pertinent to the particular end use. Installation or use not in accordance with these codes and standards could be hazardous.