

GE
Lighting Controls

GE Aware™

Passive Infrared Corner/Wall Mounted Low Voltage
Occupancy Sensor

SIR-WIDE

Overview

The SIR-Wide Corner/Wall Mount Low Voltage Occupancy Sensor is a Passive Infrared (PIR) motion sensing lighting control, used for energy savings and convenience. When motion is detected, the blue wire is electronically connected to the red wire, energizing the relay in the switchpack to turn ON the load. If vacancy is detected, the blue wire is disconnected from the red, causing the relay to open turning OFF the load. The red lead is 10 to 30 VDC supply, the black lead is common, and the blue is the relay control.

PIR Technology

The sensor's segmented lens divides the field of view into sensor zones, and detects the changes in temperature that are created when a person, or part of a person as small as a hand, passes into or out of a sensor zone.

The sensor includes self-adaptive technology that continually adjusts to conditions by adjusting sensitivity and time delay in real-time. By adjusting sensitivity and time delay automatically, the sensor is maximizing the potential energy savings that are available in the particular application. The Daylighting feature (-D model only) prevents lights from turning ON when the room is adequately illuminated by natural light.

Walk-Through feature maximizes energy savings by not leaving the lights ON after a momentary occupancy. The sensor will switch the lights ON when it detects a person entering the area. If the sensor does not continue to detect motion 30 seconds following the initial activation, it will automatically go to a shorter 2 minute time delay.

In Automatic On Mode, the lights turn ON when a person enters the room. In Manual-ON Mode, the lights are turned ON by activating a momentary switch (model # RS2-*) that is connected to the sensor. When used with 2 level lighting (-D model only), bi-level Automatic-ON can be achieved which allows Zone 1 to come ON automatically upon occupancy. Zone 2 does not come ON unless the occupant presses the optional momentary switch.



Specifications

Technology: Passive Infrared (PIR) and Ultrasonic (US)

Power Requirements:

Input:

10-30 VDC from GE Switchpack or GE system.
Maximum current needed is 25mA per sensor

Output:

Open collector output to switch up to ten GE Switchpacks. BAS with Isolated Form C Relay (-D model) isolated Form C Relay Ratings: 1A 30VDC/VAC

Time Delays: Self-Adjusting, 15 seconds/test (10 min Auto), or Selectable 5, 15, 30 minutes

Coverage: 1200 sq. ft.

Light Level Sensing: 0 to 300 foot-candles (- D model)

Operating Environment:

Temperature: 32° F – 104° F (0° C – 40° C)
Relative Humidity: up to 90% non-condensing

Housing:

Medium impact injection molded housing.
Polycarbonate resin complies with UL94V0.

Size: 4.4" x 3.4" x 2" (112mm x 86.4mm x 50.8mm)

LED Indicators: Red indicates PIR detection

Ordering

Product Code	Description	Color	Field of view	Features
63292	SIR-WIDE	White	Wide angle, 120°	
63293	SIR-WIDE-D	White	Wide angle, 120°	BAS relay & daylight sensor



RoHS

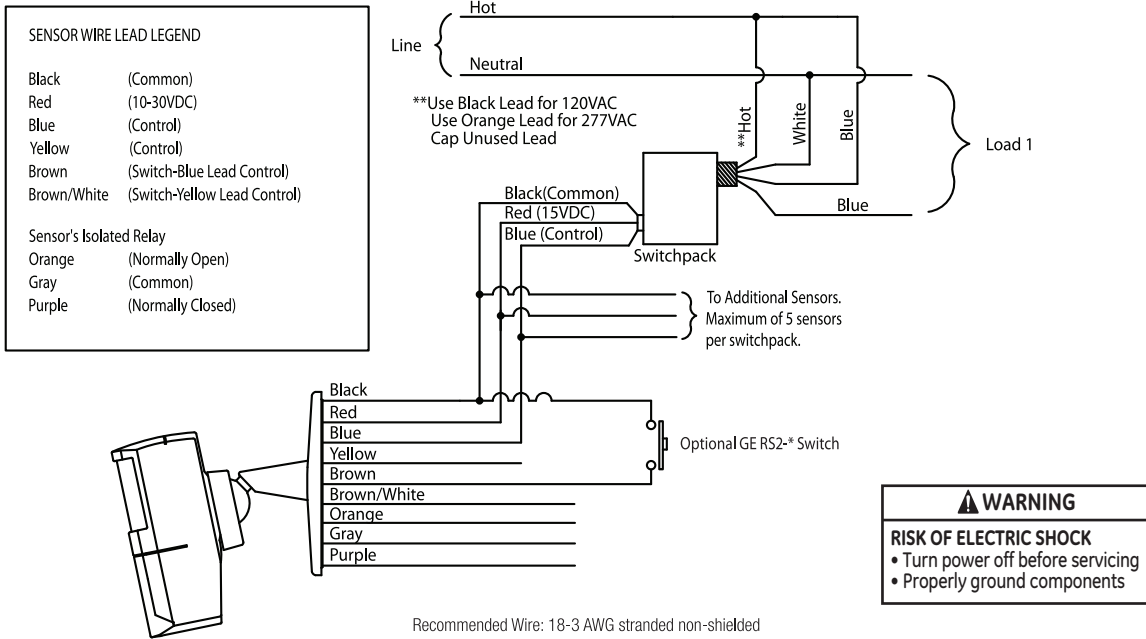

Coverage

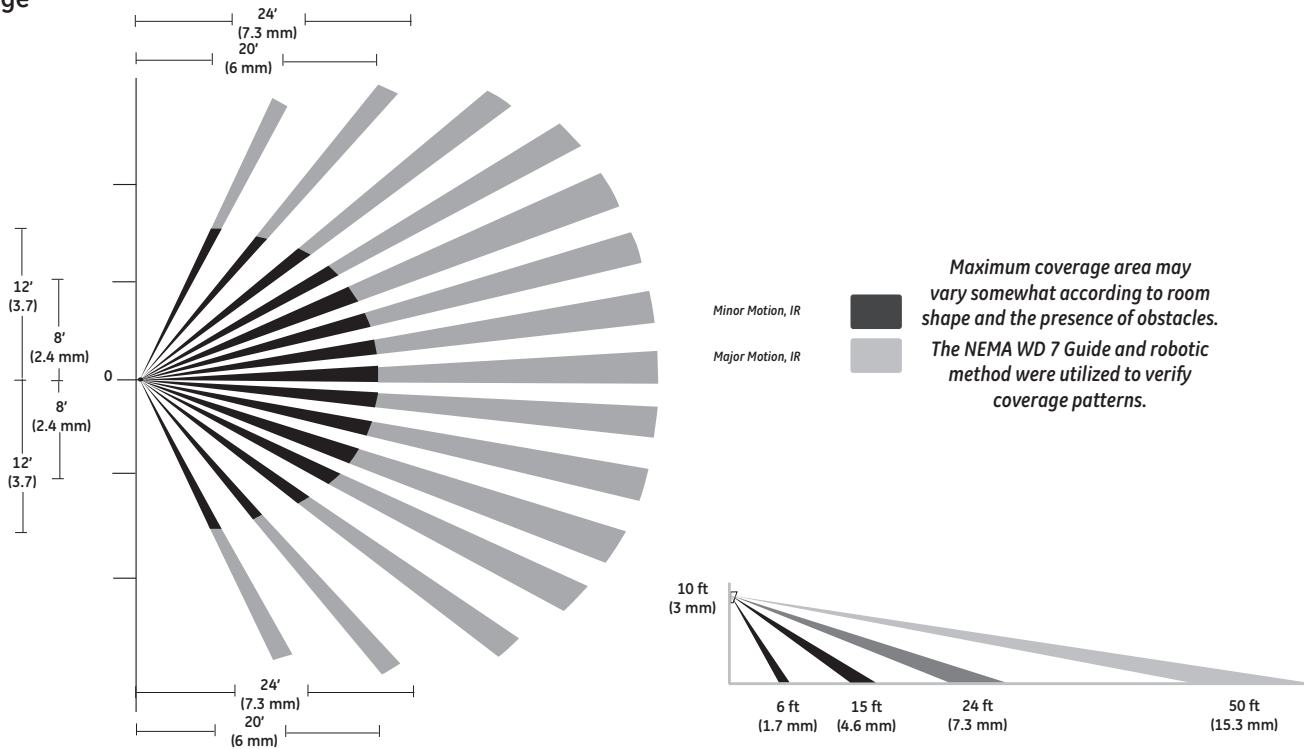

Settings

DIP Switch Legend

DIP Switch	Time Delay		Activation		PIR Sensitivity	Walk-Through Mode		LEDs	Override	Lighting Sweep	Daylighting Mode
	1	2	3	4		6	7				
	Power Pack One				Power Pack Two						
	Auto*	▼	Auto	▼	Full	Disable	Enable	Disable	Disable	Half	
	5 Minutes	▼	Manual	▲	50%	Enable	Disable	Enable	Enable	Full	
	15 Minutes	▲									
	30 Minutes	▲									

(-D model only)

*Self-Adjusts to 10 min. user mode

Default =

