



**FieldServer**  
**FS-8700-74 Veeder Root**  
**Driver Manual**  
(Supplement to the FieldServer Instruction Manual)

**APPLICABILITY & EFFECTIVITY**

Effective for all systems manufactured after November 2020.

Driver Revision: 1.04  
Document Revision: 10.H

## Technical Support

Please call us for any technical support needs related to the FieldServer product.

MSA Safety  
1991 Tarob Court  
Milpitas, CA 95035

Website: [www.sierramonitor.com](http://www.sierramonitor.com)

U.S. Support Information:

+1 408 964-4443

+1 800 727-4377

Email: [smc-support@msasafety.com](mailto:smc-support@msasafety.com)

EMEA Support Information:

+31 33 808 0590

Email: [smc-support.emea@msasafety.com](mailto:smc-support.emea@msasafety.com)

**TABLE OF CONTENTS**

**1 Veeder-Root Driver Description ..... 4**

**2 Driver Scope of Supply ..... 4**

2.1 Supplied by MSA Safety ..... 4

2.2 Provided by the Supplier of 3<sup>rd</sup> Party Equipment..... 4

2.2.1 Required 3<sup>rd</sup> Party Hardware..... 4

**3 Hardware Connections..... 5**

3.1 Verifying Comm Settings at the Veeder Root Panel ..... 6

3.1.1 TLS-3XX ..... 6

3.1.2 TSL-4XX ..... 7

**4 Data Array Parameters ..... 8**

**5 Configuring the FieldServer as a Veeder-Root Client..... 9**

5.1 Client Side Connection Parameters ..... 9

5.2 Client Side Node Descriptors ..... 10

5.3 Client Side Map Descriptor Parameters ..... 10

5.3.1 FieldServer Specific Map Descriptor Parameters ..... 10

5.3.2 Driver Specific Map Descriptor Parameters ..... 11

5.3.3 Timing Parameters ..... 11

5.4 Map Descriptor Examples ..... 12

5.4.1 Alarms ..... 12

5.4.2 Inventory TLS-350 Device..... 13

5.4.3 Inventory TLS-450 Device..... 13

5.4.4 Most Recent Delivery Report ..... 14

**6 Configuring the FieldServer as a Veeder-Root Server..... 15**

**Appendix A Useful Features ..... 16**

Appendix A.1 Resetting Remote Alarms ..... 16

Appendix A.2 System Configuration..... 16

Appendix A.3 Advanced Example – System Diagnostics ..... 16

Appendix A.4 System Revision Level Report I..... 17

Appendix A.5 System Revision Level Report II..... 17

Appendix A.6 Stick Height Report..... 18

Appendix A.7 Active Alarm Report..... 18

Appendix A.8 Cleared Alarm Report ..... 19

Appendix A.9 Security Codes..... 20

**Appendix B Troubleshooting..... 21**

**Appendix C Reference..... 22**

Appendix C.1 Supported Functions..... 22

Appendix C.1.1 Alarm Categories Supported..... 22

Appendix C.1.1.1 Unknown-Category..... 22

Appendix C.1.2 TLS-350 Device Support..... 23

Appendix C.1.3 TLS-450 Device Support..... 23

Appendix C.2 Alarm Tables..... 24

Appendix C.3 Data Type and Required Lengths..... 30

Appendix C.4 Module Types ..... 30

Appendix C.5 Error Messages ..... 31

Appendix C.6 Driver Stats ..... 33

## 1 VEEDER-ROOT DRIVER DESCRIPTION

The Veeder-Root Serial Driver allows the FieldServer to transfer data to and from devices over either RS-232 or RS-485 ports using Veeder-Root protocol as defined in Veeder-Root Document 576013-635 Revision J. The Veeder-Root Driver supports TLS350 as per Veeder-Root Document 576013-635 Revision Y, and TLS450 as per Veeder-Root Document 577013-950 Revision G. Since the data protocol is the same for the TLS350+ as for TLS350, it is assumed that the driver will support the TLS350+ but this has not been tested. Refer to **Section 3** for hardware connections.

The FieldServer emulates a Client.

The Veeder-Root Serial Driver is a poll response driver. Only one query or command can be processed at a time.

A limited set of the queries and commands defined in the protocol specification have been implemented. The reason for the limitation is two-fold. Firstly, not all commands/queries will have any meaning to a Server device as they are principally defined to configure the Veeder-Root Device. Secondly some commands return very complex data sets which cannot be processed in a method suitable for loading into the FieldServer's Data Arrays.

The driver is capable of exposing its communications statistics which allows them to be monitored using a Server device. This ensures data is valid by generating alarms if communication problems arise.

## 2 DRIVER SCOPE OF SUPPLY

### 2.1 Supplied by MSA Safety

Part #	Description
FS-8917-07	RJ45 to DB25M connection adapter
FS-8917-16	UTP (Cat-5) cable (7 foot) for RS-232 use
FS-8917-27 (for TLS-450 panel)	RJ45 to DB9M Connector

### 2.2 Provided by the Supplier of 3<sup>rd</sup> Party Equipment

#### 2.2.1 Required 3<sup>rd</sup> Party Hardware

Part #	Description
	Veeder-Root Panel

### 3 HARDWARE CONNECTIONS

The FieldServer is connected to the Veeder-Root Panel as shown below.

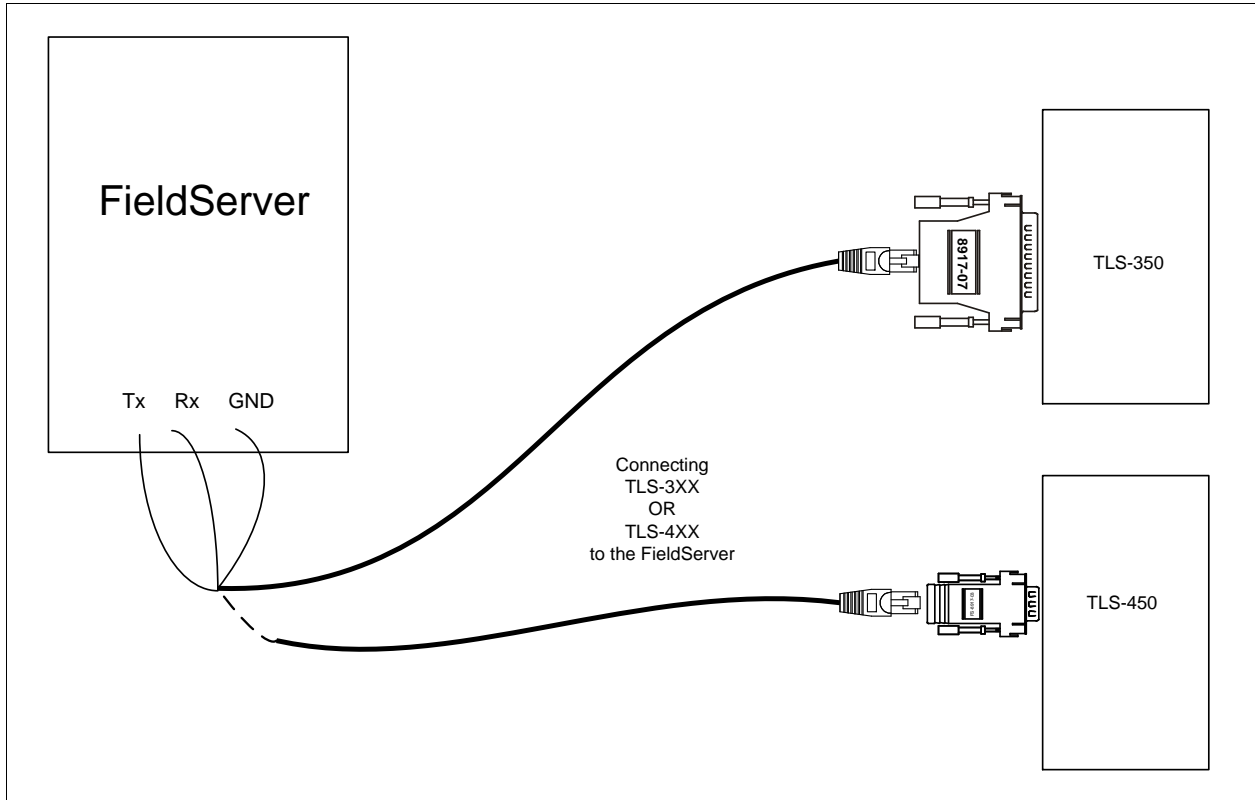

TLS-350 Connector Pinout				TLS-450 Connector Pinout			
Function	RJ45 Pin#	DB25M Pin#	Color	Function	RJ45 Pin #	DB9M Pin #	Color
RX	1	2	White	RX	01	03	White
CTS	2	5	Brown	CTS	02	08	Brown
DSR	3	8	Yellow	DSR	03	06	Yellow
GND	4	7	Green	GND	04	05	Green
DTR	6	20	Black	DTR	06	04	Black
RTS	7	6	Orange	RTS	07	07	Orange
TX	8	3	Blue	TX	08	02	Blue

FieldServer Pinouts for TLS-350		FieldServer Pinouts for TLS-450	
TLS Pin	RS-232 Pin	TLS Pin	RS-232 Pin
TX +	TX +	RX -	TX +
RX -	RX -	TX +	RX -
GND	GND	GND	GND

**NOTE:** For connecting to the TLS-350, Veeder Root part # 329362-001 comm board must be installed which has the RS-232 serial port, general purpose interface.

**NOTE:** For specific TLS programming details, go [here](#) and refer to 577013-623.

## 3.1 Verifying Comm Settings at the Veeder Root Panel

### 3.1.1 TLS-3XX

- From the front screen that shows the time/date, press MODE until “SETUP MODE” menu appears.
- Press FUNCTION until “COMMUNICATIONS SETUP” appears.
- Press STEP to get to “PORT SETTINGS” menu. Press ENTER to get into “PORT SETTINGS” menu.
- The “PORT SETTINGS” menu shows the following parameters:
  - Comm Board: 1 (RS-232)
  - Baud Rate
  - Parity
  - Stop Bit
  - Data Length
  - Code
- To scroll through the parameters, press the STEP button.
- To modify a parameter, press the STEP button until the parameter appears on the screen and push CHANGE to modify. Press ENTER, then follow the prompt by pressing STEP.
- If the operator “gets lost” in the menus, press MODE until the front screen showing time/date appears.

3.1.2 TSL-4XX

To configure the serial port on a TLS-4XX console, navigate to Setup->Communications->Serial Port screen and set up the port as shown below:

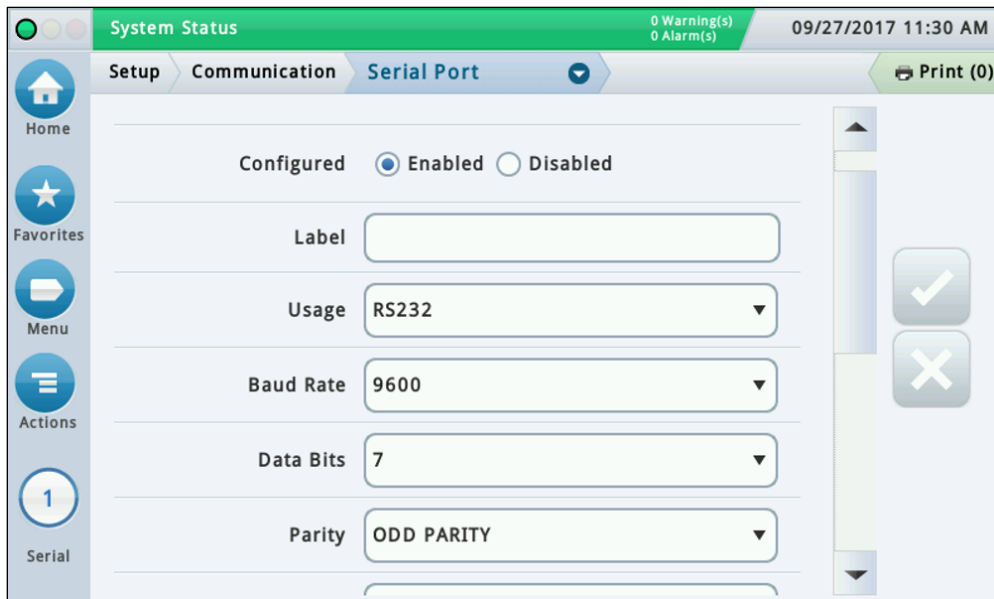

To configure com port security on a TLS-4XX console, navigate to Setup->Communications->Serial Port screen, then select the Serial Command Security Enabled button and enter the security code.



## 4 DATA ARRAY PARAMETERS

Data Arrays are “protocol neutral” data buffers for storage of data to be passed between protocols. It is necessary to declare the data format of each of the Data Arrays to facilitate correct storage of the relevant data.

Section Title		
Data_Arrays		
Column Title	Function	Legal Values
Data_Array_Name	Provide name for Data Array.	Up to 15 alphanumeric characters
Data_Array_Format	Provide data format. Each Data Array can only take on one format.	Float, Bit, Byte, Uint16, Uint32, Sint16, Sint32
Data_Array_Length	Number of Data Objects. Must be larger than the data storage area required by the Map Descriptors for the data being placed in this array.	1-10000

**Example**

```

// Data Arrays
Data_Arrays
Data_Array_Name , Data_Array_Format , Data_Array_Length
DA_AI_01        , Uint16             , 200
DA_AO_01        , Uint16             , 200
DA_DI_01        , Bit                , 200
DA_DO_01        , Bit                , 200
    
```



## 5 CONFIGURING THE FIELDSEVER AS A VEEDER-ROOT CLIENT

For detailed information on FieldServer configuration, refer to the FieldServer Configuration manual. The information that follows describes how to expand upon the factory defaults provided in the configuration files included with the FieldServer.

This section documents and describes the parameters necessary for configuring the FieldServer to communicate with a Veeder-Root Device.

The configuration file tells the FieldServer about its interfaces, and the routing of data required. In order to enable the FieldServer for Veeder-Root Driver communications, the driver independent FieldServer buffers need to be declared in the “Data Arrays” section, the destination device addresses need to be declared in the “Client Side Nodes” section, and the data required from the Servers needs to be mapped in the “Client Side Map Descriptors” section. Details on how to do this can be found below.

**NOTE: In the tables below, \* indicates an optional parameter and the bold legal values are default.**

### 5.1 Client Side Connection Parameters

Section Title		
Connections		
Column Title	Function	Legal Values
Port	Specify which port the device is connected to the FieldServer.	P1-P2, R1-R2 <sup>1</sup>
Baud*	Specify baud rate.	Standard baud rates up to 9600 (TLS-350), 115200 (TLS-450), <b>9600</b>
Parity*	Specify parity.	Even, Odd, <b>None</b>
Data_Bits*	Specify data bits.	7, <b>8</b>
Stop_Bits*	Specify stop bits.	<b>1</b> , 2
Protocol	Specify protocol used.	Vroot, Veeder
Poll Delay*	Time between internal polls.	0-32000 seconds, <b>1 second</b>

**Example**

```
// Client Side Connections

Connections
Port , Baud , Parity , Protocol , Poll_Delay
P1 , 9600 , None , Vroot , 0.100s
```

<sup>1</sup> Not all ports shown are necessarily supported by the hardware. Consult the appropriate Instruction manual for details of the ports available on specific hardware.

## 5.2 Client Side Node Descriptors

Section Title		
Nodes		
Column Title	Function	Legal Values
Node_Name	Provide name for node.	Up to 32 alphanumeric characters
Protocol	Specify protocol used.	Vroot, Veeder
Port	Specify which port the device is connected to the FieldServer.	P1-P2, R1-R2 <sup>2</sup>
Route*	Route is only required if security is enabled on the Veeder-Root device. The route must be set to contain the 6 digits that form the security code. Refer to <a href="#">Appendix A.9</a> .	Decimal digits in the range 0 to 9 in the format a.b.c.d.e.f
Plc_Type*	Specify the type of Veeder Root Panel.	TLS-450, the default is "-" which defaults to a TLS-350 connection

### Example

```
// Client Side Nodes

Nodes
Node_Name      , Protocol  , Port  , Plc_Type
VR_Node1      , Vroot   , P1   , TLS-450
```

## 5.3 Client Side Map Descriptor Parameters

### 5.3.1 FieldServer Specific Map Descriptor Parameters

Column Title	Function	Legal Values
Map_Descriptor_Name	Name of this Map Descriptor.	Up to 32 alphanumeric characters
Data_Array_Name	Name of Data Array where data is to be stored in the FieldServer.	One of the Data Array names from <a href="#">Section 4</a>
Data_Array_Location	Starting location in Data Array.	0 to maximum specified in <a href="#">Section 4</a>
Function	Function of Client Map Descriptor.	Rdbc, Wrbc, Wrbx, Passive, Passive_Client

<sup>2</sup> Not all ports shown are necessarily supported by the hardware. Consult the appropriate Instruction manual for details of the ports available on specific hardware.

### 5.3.2 Driver Specific Map Descriptor Parameters

Column Title	Function	Legal Values
Node_Name	Name of Node to fetch data from.	One of the Node names specified in <b>Section 5.2</b>
Data_Type	Data type	System Status, In-Tank Inventory, In-Tank Inventory with Ullage, In-Tank Delivery, Active Alarm Report, In-Tank Stick Height, Configuration, Remote Alarm Reset, Misc
Veed_Alarm_Category	An alternative to Data_Type parameter to support more known alarm categories and future unknown categories. This parameter should be used on Passive Map Descriptors to store alarms returned by "System Status" report. <sup>3</sup>	See <b>Appendix C.1.1</b> ; <b>0</b>
Length	Length of Map Descriptor - The length is used to tell the driver how many elements of the Data Array are under the control of the Map Descriptor. This is important because the driver uses the length to, for example, clear Data Array elements when a Tank/Sensor has no alarms.	1 – 1000; refer to <b>Appendix C.1.1</b> for required lengths for specific alarms
Address* <sup>4</sup>	The address is used to specify the Tank/Sensor/ Input/Relay ... Number to be used in the poll. For some data types the address has no meaning and should be set to 1. When zero is used as the value of the address then (in most cases) the driver polls for all Tanks/ Sensors belonging to that data type.	<b>0, 1, 2, 3...</b> ; Veeder-Root Tanks / Sensors ... are numbered from 1. The maximum tank number is 16 (350 console) or 64 (450 console) and the maximum sensor number is 64.
Veed_Function	The Veed function number can be specified.	Specify using the notation 0xnnn where nnn is the function number (e.g. 0x901)
DA_Byte_Name*	This is an optional Data Array that can be defined to store additional information. The information returned is specific to the Data Type. Refer to <b>Appendix A.2</b> and <b>Appendix A.8</b> for examples using this parameter.	One of the Data Array names from <b>Section 4</b> , -
DA_Float_Name*	This is an optional Data Array that can be defined to store the Current value for the Configuration Data Type. Refer to <b>Appendix A.2</b> .	One of the Data Array names from <b>Section 4</b> , -

### 5.3.3 Timing Parameters

Column Title	Function	Legal Values
Scan_Interval	Rate at which data is polled	>0.1s

<sup>3</sup> In the future, additional categories may be added. The category number can be used as the value for the Veed\_Alarm\_Category.

<sup>4</sup> See **Appendix C.1** for Data Type, Address and Length Limitations.

## 5.4 Map Descriptor Examples

### 5.4.1 Alarms

This example provides one Map Descriptor to poll for alarm data and many Map Descriptors to store the response from the poll. One Map Descriptor is required for each tank/sensor/input/device defined for the system. The address of each of these passive Map Descriptors must correspond to the tank/sensor/input/device number. For example, where 5 tanks are defined as tanks 1,2,3,6,7 then 5 Map Descriptors with the data type 'Tank' are required and the address of each of these 5 Map Descriptors must be set to 1,2,3,6,7. The length parameter tells the driver how much array space is reserved for each tank/sensor for storing alarms.

Only the Map Descriptor used to generate the poll requires a scan interval.

The address must correspond to the tank/sensor/input/device number. One Map Descriptor required for each tank/sensor/input/device.

Map_Descriptor_Name	Scan_Interval	Data_Array_Name	Data_Array_Offset	Function	Node_Name	Address	Length	Data_Type
Poller	5.0s	DA_450_P101	0	Rdbc	Node_450	1	17	System Status
Map_Descriptor_Name	Data_Array_Name	Data_Array_Offset	Function	Node_Name	Address	Length	Veed_Alarm_Category	
SMB_450-1	DA_450_1	0	passive_client	Node_450	1	1	System	
SMB_450-2	DA_450_2	0	passive_client	Node_450	1	1	Tank	
SMB_450-3	DA_450_3	0	passive_client	Node_450	1	1	Liquid Sensor	
SMB_450-4	DA_450_4	0	passive_client	Node_450	1	1	Vapor Sensor	
SMB_450-5	DA_450_5	0	passive_client	Node_450	1	1	Input	
// unknown categories could be defined using number								
SMB_450-98	DA_450_98	0	passive_client	Node_450	1	1	98	

Data is stored in the Data Arrays at the offset tabulated in [Appendix C.2](#).

Passive Map Descriptors do not generate messages. They are used to store data returned by the system status poll.

The length parameter tells the driver how much array space must be reserved for storing alarms for a given tank/sensor/input/device.

When an alarm occurs for tank 1, the driver stores the alarm type by setting the array position corresponding to the alarm type to a non-zero value as well as setting the first element of the reserved space non-zero as a summary. Refer to [Appendix C.2](#) for alarm type numbers and descriptions.

**Example:** Tank 1 has two alarms

- 02 = Tank Leak Alarm
- 05 = Tank Low Product Alarm

The driver sets array DA\_T1 as follows:

Index=0: Value=1 (Summary); Index=2: Value=2 (Leak); Index=5: Value=5 (Product)

### 5.4.2 Inventory TLS-350 Device

This example illustrates a poll for Tank Inventory Data. One Map Descriptor is required for each tank. The address should correspond to the tank number. The Length parameter tells the driver how much storage space to reserve for storing the inventory data. The inventory data is stored as follows:

Index	Contents
0	Product Code (Example Array value = 49 indicates product code = ASCII '1')
1	Tank Status (Bit 1 - (LSB) Delivery in Progress, Bit 2 - Leak Test in Progress, Bit 3 - Invalid Fuel Height Alarm (MAG Probes Only))
2	Volume
3	TC Volume
4	Ullage
5	Height
6	Water
7	Temperature
8	Water Volume

Map_Descriptor_Name	Data_Array_Name	Data_Array_Offset	Function	Scan_Interval	Node_Name	Address	Length	Data_Type
InventoryPoll1	DA_INVENTORY	0	Rdbc	1.0s	Node_A	1	10	In-Tank Inventory

Reading the inventory requires an active Map Descriptor.

Set the address to the tank number. One Map Descriptor per tank.

This is the minimum number of Data Array elements required to store inventory data. Tanks 1's data will be stored in the array DA\_INVENTORY starting at the zero element (offset=0) and 10 elements of the array are reserved for this data.

Setting the data type generates the correct poll. Ensure that the spelling and punctuation are exactly the same as shown in this example.

### 5.4.3 Inventory TLS-450 Device

Map_Descriptor_Name	Data_Array_Name	Data_Array_Offset	Function	Node_Name	Address	Length	Veed_Function	Data_Type
SMB_IV450	DA_450INVENT	0	Rdbc	Node_450	1	9	0x201	In-Tank Inventory

#### 5.4.4 Most Recent Delivery Report

This example illustrates a poll for Tank Delivery Data. One Map Descriptor is required for each tank. The address should correspond to the tank number. The Length parameter tells the driver how much storage space to reserve for storing the delivery data. The delivery data is stored as follows. (This function corresponds to the function 20C in the Veeder-Root protocol specification).

Index	Contents
0	Product Code
1	Number of Deliveries
2	Start Time
3	Stop Time
4	Starting Volume
5	Starting TC Volume
6	Starting Water
7	Starting Temp
8	Ending Volume
9	Ending TC Volume
10	Ending Water
11	Ending Temp
12	Starting Height
13	Ending Height

Map_Descriptor_Name	Data_Array_Name	Data_Array_Offset	Function	Scan_Interval	Node_Name	Address	Length	Data_Type
DeliveryPoll01	DA_DELIVERY	0	Rdbc	1.0s	Node_A	1	30	In-Tank Delivery

## **6 CONFIGURING THE FIELD SERVER AS A VEEDER-ROOT SERVER**

The server functionality of this driver was developed for testing the Client. Its features are not documented and not intended for end-users. It may be possible to extend and document the server at the request of an end-user.

## APPENDIX A USEFUL FEATURES

### Appendix A.1 Resetting Remote Alarms

This example provides a 'write-on-change' Map Descriptor used to send the Veeder-Root device a remote alarm reset command. When the value of the first element of the array named DA\_COMMANDS changes value, the driver will send the command. The driver stores the Veeder-Root System time in the array on completion of the command.

Map_Descriptor_Name	Data_Array_Name	Data_Array_Offset	Function	Node_Name	Address	Length	Data_Type
Reset_Alms_01	DA_COMMANDS	0	Wrbc	Node_A	1	30	Remote Alarm Reset

### Appendix A.2 System Configuration

This example reads the configuration of the Veeder-Root Panel. The module type is stored in the location corresponding to the slot number. Slot 1's data is stored at index location 0, slot 2 at index location 1, and if the DA\_Byte\_Name and DA\_Float\_Name arrays are defined then the driver also stores the Power on Reset and Current Values in the corresponding array locations.

The table below provides a listing of module types.

Map_Descriptor_Name	Data_Array_Name	Data_Array_Offset	Scan_interval	Function	Node_Name	Address	Length	Data_Type		
Config_poll_1	DA_MODULES	0	10.0s	Rdbc	Node_A	1	30	Configuration		
Map_Descriptor_Name	Data_Array_Name	DA_Byte_Name	DA_Float_Name	Data_Array_Offset	Scan_interval	Function	Node_Name	Address	Length	Data_Type
Config_poll_1	DA_MODULES	DA_POWER	DA_CURRENT	0	10.0s	Rdbc	Node_A	1	30	Configuration

Power-On-Reset and Current values are also stored if the DA\_Byte\_Name and the DA\_Float\_Name parameters are defined. The data format must be set to UINT32 or FLOAT.

### Appendix A.3 Advanced Example – System Diagnostics

This example reads the System Diagnostics Report from the Veeder-Root Panel. The results are stored in 3 consecutive array elements. If the value is set non-zero, then the test FAILED. A value of zero means the test passed.

Index Contents

I/O test result

Ram test result

Prom test result

Map_Descriptor_Name	Data_Array_Name	Data_Array_Offset	Scan_interval	Function	Node_Name	Address	Length	Veed_Function	Data_Type
System1poll_1	DA_SELF_TEST	0	10.0s	Rdbc	Node_A	1	3	0x901	Misc.



Appendix A.4 System Revision Level Report I

This example reads the System Revision Level from the Veeder-Root Panel. The result is stored in ASCII using up to 100 consecutive array elements. Use an array format BYTE or STRING for this function.

Map_Descriptor_Name	Data_Array_Name	Data_Array_Offset	Scan_interval	Function	Node_Name	Address	Length	Veed_Function	Data_Type
System1poll_1	DA_REVISION	0	10.0s	Rdbc	Node_A	1	100	0x902	Misc.

The following string will be returned and can be interpreted as described below.

YYMMDDHHmmSOFTWARE# nnnnnn-vvv-rrrCREATED - YY.MM.DD.HH.mm&&CCCC<ETX>

- YYMMDDHHmm** - Current Date and Time
- nnnnnn-vvv** - Software version number (ASCII text string)
- rrr** - Software revision level (ASCII text string)
- YY.MM.DD.HH.mm** - Date and time of software creation
- &&** - Data Termination Flag
- CCCC** - Message Checksum

Appendix A.5 System Revision Level Report II

This example reads additional System Revision Level data from the Veeder-Root Panel. The result is stored in ASCII using up to 100 consecutive array elements. Use an array with format BYTE or STRING for this function. The notes below explain how the data should be interpreted.

Map_Descriptor_Name	Data_Array_Name	Data_Array_Offset	Scan_interval	Function	Node_Name	Address	Length	Veed_Function	Data_Type
System1poll_1	DA_REVISION2	0	10.0s	Rdbc	Node_A	1	100	0x905	Misc.

The following string will be returned and can be interpreted as described below.

i90500YYMMDDHHmmSOFTWARE# 346abb-Tvv-rrrCREATED - YY.MM.DD.HH.mmnnAABCCDDEEFFGGHHIIJJS-MODULE# nnnnnn-vvv-r

YYMMDDHHmm	Current Date and Time
346	Software Base number (fixed)
a	Platform (0 = Standard CPU, PLLD only 1 = Enhanced CPU 2 = (Unused) 3 = Enhanced CPU 16 Tank 4 = Standard CPU without PLLD & WPLLD 5 = Standard CPU, WPLLD only)
bb	Version level (eg version "15")
T	Software Type (1 = "Real" 2 = "Demo" 3 = "IFSF")
vv	Language
rrr	Revision level (e.g. revision "AX1")
YY.MM.DD.HH.mm	Date and time of software creation
nn	number of 2 byte values to follow (Hex)
AA	PERIODIC IN TANK TESTS (00 = DISABLE, 01 = ENABLE)
BB	ANNUAL IN TANK TESTS (00 = DISABLE, 01 = ENABLE)
CC	CSLD (00 = DISABLE, 01 = ENABLE)
DD	BIR (00 = DISABLE, 01 = ENABLE)

EE	FUEL MANAGER (00 = DISABLE, 01 = ENABLE)
FF	PRECISION PLLD (00 = DISABLE, 01 = ENABLE)
GG	TANKER LOAD (00 = DISABLE, 01 = ENABLE)
HH	0.2 GPH PLLD (00 = DISABLE, 01 = ENABLE)
II	PRECISION PLLD ON DEMAND (00 = DISABLE, 01 = ENABLE)
JJ	SPECIAL 3 TANK/LINE CONSOLE (00 = DISABLE, 01 = ENABLE)
SEM Info 3 parts, if none "NO SOFTWARE MODULE"	
nnnnnn	SEM number (ASCII text string)
vvv	SEM Software version number (ASCII text string)
r	SEM Software Revision number (ASCII text string)

### Appendix A.6 Stick Height Report

This example reads the Stick Height Report from the Veeder-Root Panel. The result is stored as a real number. Scaling may be applied if specified in the Map Descriptor. Refer to the FieldServer Configuration manual. Use one Map Descriptor per tank.

Map_Descriptors								
Map_Descriptor_Name	Data_Array_Name	Data_Array_Offset	Scan_Interval	Function	Node_Name	Address	Length	Data_Type
Poll_Height1	DA_STICKHEIGHT	0	0.8s	Rdbc	Node_A	1	1	In-Tank Stick Height

### Appendix A.7 Active Alarm Report

This example reads the Veeder-Root Panel for active alarms (includes acknowledged and active). If there are any active alarms, then the 1<sup>st</sup> element of the Data Array is set non-zero. If there are no active alarms, then the array element is set to zero. A number of passive Map Descriptors are required to store alarms for the tanks. Sensor / inputs / devices as described in **Section 5.4**.

Map_Descriptors								
Map_Descriptor_Name	Data_Array_Name	Data_Array_Offset	Scan_Interval	Function	Node_Name	Address	Length	Data_Type
AlarmPoll-11	DA_ACTIVEALM	0	2.0s	Rdbc	Node_A	1	1	Active Alarm Report

Appendix A.8 Cleared Alarm Report

This example reads the Veeder-Root Panel for cleared alarms. If there are any cleared alarms, then the 1<sup>st</sup> element of the Data Array is set non-zero. If there are no cleared alarms, then the array element is set to zero. A number of passive Map Descriptors are required to store the cleared alarm info for the tanks. Sensor / inputs / devices as described in **Section 5.4**.

The data is stored in the array specified using the DA\_Byte\_Name parameter of the passive Map Descriptors.

A stored value of “1” indicates Alarm Cleared. A stored value of “1 2” shows alarm occurred.

The value is stored at the location which corresponds to the alarm type.

Thus, if a 02 = Tank Leak Alarm was cleared then at index=2 the value stored will be 1.

Active alarms are stored in the primary array.

Map_Descriptor_Name	Data_Array_Name	Data_Array_Offset	Scan_Interval	Function	Node_Name	Address	Length	Data_Type
AlarmPoll-11	DA_ACTIVEALM	0	2.0s	Rdbc	Node_A	1	1	Active Alarm Report
Map_Descriptors								
Map_Descriptor_Name	Data_Array_Name	DA_Byte_Name	Data_Array_Offset	Function	Node_Name	Address	Length	Veed_Alarm_Category
Sys_alms01	DA_S1	DA_S1_CLEAR	0	passive	Node_A	1	30	System
Tank_Alms1	DA_T1	DA_T1_CLEAR	0	passive	Node_A	1	30	Tank

The cleared alarm information is stored in the secondary array specified with the DA\_Byte\_Name.

## Appendix A.9 Security Codes

The RS-232 security code is an optional six-digit code used to limit external serial access to the system for security purposes. It can be set to any unique set of characters using either the front panel switches or the external communication interface setup commands. The system will not respond to a command without the proper security code if the DIP switch is set to enable RS-232 security.

A four-position DIP switch is located on the CPU board, which is mounted in the right-back of the console printer compartment beside the battery switch. The DIP switch enables the security code and the switch positions are assigned as follows:

### Switch

- 1 Front Panel Setup Security Enable
- 2 RS-232 Security Enable
- 3, 4 Unused

If RS-232 security is enabled, then the **Route** parameter must be specified for the node. Set the route parameter equal to the security code. Use a period to separate each digit of the code.

Example: Security Code=234419  
Route = 2.3.4.4.1.9

Alphabetic characters cannot be directly specified in the route field. They need to be specified as ASCII values.

Example: Security Code = 123abc  
Route = 1.2.3.97.98.99

If the security feature has been disabled on the panel set the route to dash (-).

**APPENDIX B TROUBLESHOOTING**

1. The number of messages received should equal the number of messages sent.
2. The number of errors should represent a small percentage of the total number of messages sent (< 5%).
3. Several errors in consecutive messages may cause the FieldServer kernel to place the node offline in which case polling is slowed significantly until good communications are re-established.
4. If the number of messages received is zero and the number of timeouts is equal to the number of messages sent then:
  - a. The connection is bad. Check the cables
  - b. The security configuration is invalid
  - c. The port settings are incorrect. Check the baud rate
5. If the number of messages received and sent are roughly equal and the number of errors is small but the Data Arrays do not update then:
  - a. If polling for System Status – Check the 1<sup>st</sup> element of the Data Array associated with the poll Map Descriptor. The driver sets or clears the element as a summary alarm state for the Veeder Root device.
  - b. Check that the data age is less than the scan interval.
6. If the number of messages ignored is non-zero then this indicates that some data cannot be stored and is being discarded. Generally, this arises when the driver cannot find an appropriate Map Descriptor to store data received in response to a poll (for composite data such as system status). For example: A system alarm occurs but Map Descriptors have not been defined to store system alarms.
7. Monitor the error log to see if the driver has reported any errors or important information. These messages arise in two ways.
  - a. Configuration errors and warnings arise from the way that the CSV file has been configured. These should be eliminated during set-up.
  - b. Errors may arise from some run-time condition. Many of these errors are produced in the error log once and then suppressed so that the log does not overflow or hide other meaningful information. These messages are preceded by an \*.

**APPENDIX C REFERENCE**

Appendix C.1 Supported Functions

Appendix C.1.1 Alarm Categories Supported

The Veeder-Root protocol specification defines a large number of enquiries and commands that may be sent to a Veeder-Root device. This driver supports the following functions for each device type:

Index	Contents
1	System
2	Tank
3	Liquid Sensor
4	Vapor Sensor
5	Input
6	Volumetric Line
7	Groundwater Sensor
8	Type-A Sensor
11	Relay Alarm
12	Type-B Sensor
13	Universal Sensor
14	Auto-Dial
18	Mech. Dispenser
19	Elec. Dispenser
20	Product
21	Press. Line
26	WPLLD
28	Smart Sensor
29	Modbus Alarm
30	ISD Site
31	ISD Hose
32	ISD Vapor Flow Meter
33	PMC
34	Pump Relay Monitor
35	VMCI Dispensor Interface
36	VMC
37	VPM

Index	Contents
58	ISD Ullage Pressure sensor
59	MAG Sensor
60	Vacuum Sensor
63	Line Pressure Sensor
64	Printer
65	Pump
66	Line
69	Legacy Resistive Sensor
70	Legacy Current Sensor
71	Unknown Device
72	Undiscovered Device
73	Communication
74	Contact
75	AutoEvent
76	LVDIM
77	CDIM
78	MDIM
79	EDIM
80	USM Card
81	IOM Card
82	MUX Card
83	Open Circuit
84	Blend
85	Meter Temp Sensor
86	USIOM Card
99	External

Appendix C.1.1.1 Unknown-Category

The Unknown-Category is used to store the most current alarm of a device type that has not been specified in the config. The device address, alarm category, and alarm type will be stored in the offsets of the specified data array as follows:

Point	Data_Array_Offset
Unknown Device Address	0
Unknown Alarm Category	1
Unknown Alarm Type	2

**Example**

```
Map_Descriptors
Map_Descriptor_Name , Data_Array_Name , Data_Array_Offset , Length , Function
CMD_CAT_Unknown , DA_UNKCAT , 000 , 3 , Passive_client
```

```
, Node_Name , Address , Veed_Alarm_Category
, Node_A , - , Unknown-Category
```

Appendix C.1.2 TLS-350 Device Support

The revision number indicates the minimum Veeder-Root firmware revision required for support of the function. The function numbers are hexadecimal numbers. Either convert them to decimal or specify them in the CSV file using the notation 0xnnn where nnn is the function number.

Function	Revision	Description
<b>SYSTEM REPORTS (7.2.1)</b>		
101	1	System Status Report
102	1	System Configuration Report
113	14	Active Alarm Report
114	19	Cleared Alarm Report
<b>IN-TANK REPORTS (7.2.2)</b>		
201	1	In-Tank Inventory Report
202	1	In-Tank Delivery Report
204	1	In-Tank Shift Inventory Report
20D	15	In-Tank Stick Height Report
21A	-	In-Tank Inventory with Ullage
<b>SENSOR REPORTS (7.2.3)</b>		
301	1	Liquid Sensor Status Report
306	1	Vapor Sensor Status Report
311	1	Groundwater Sensor Status Report
341	2	Type A (2 Wire CL) Sensor Status Report
346	2	Type B (3 Wire CL) Sensor Status Report
34B	4	Universal Sensor Status Report
<b>LINE LEAK REPORTS (7.2.4)</b>		
381	7	Pressure Line Leak Status
386	10	WPLLD Line Leak Status
<b>I/O DEVICE REPORTS (7.2.6)</b>		
401	1	Input Status Report
406	1	Relay Status Report
<b>SYSTEM DIAGNOSTIC REPORTS (7.4.1)</b>		
901	1	Self Test Results Report
902	1	System Revision Level Report
905	15	System Revision Level Report II
<b>CONTROL FUNCTIONS (7.1)</b>		
1	1	System Reset
2	1	Clear Power Reset Flag
3	1	Remote Alarm Reset
31	10	Confirm Clear Function
51	1	Clear In-Tank Delivery Reports
52	1	Start In-Tank Leak Detect Test
53	1	Stop In-Tank Leak Detect Test
54	5	Delete CSLD Rate Table
81	7	Start Pressure Line Leak Test (3.0 GPH only in V18)
82	7	Stop Pressure Line Leak Test
83	10	Start WPLLD Line Leak Test (3.0 GPH only in V18)
84	10	Stop WPLLD Line Leak Test

Appendix C.1.3 TLS-450 Device Support

Function	Revision	Description
<b>SYSTEM REPORTS</b>		
101	1	System Status Report
<b>IN-TANK REPORTS</b>		
201	1	In-Tank Inventory Report
21A	-	In-Tank Inventory with Ullage

Appendix C.2 Alarm Tables

The following data will be stored for each alarm type in Data Arrays as set up in the example in **Section 5.4**.

Alarm_Category	Data Array Offset	Description	TLS-450 Availability
System	1	Printer out of Paper	Obsolete
	2	Printer Error	Obsolete
	3	EEPROM Configuration Error	Obsolete
	4	Battery Off	Obsolete
	5	Too Many Tanks	Obsolete
	6	System Security Warning	Obsolete
	7	ROM Revision Warning	Obsolete
	8	Remote Display Communications Error	Obsolete
	9	Autodial Error	Obsolete
	10	Software Module Warning	Obsolete
	11	Tank Test Shutdown Warning	Obsolete
	12	Protective Cover Alarm	Obsolete
	13	BIR Shift Close Pending	Version 2
	14	BIR Daily Close Pending	Version 2
	15	PC(H8) Revision Warning	Obsolete
	16	System Self Test Error	Obsolete
	17	System Clock Incorrect Warning	Obsolete
	18	System Device Poll Timeout	Obsolete
	19	Maintenance Tracker NVMem Removed	Obsolete
	20	Maintenance Tracker Communication Module Removed	Obsolete
	21	Database Error	
	22	File System Error	
	23	BIR Status Warning	Version 2
	24	VR Bus Power Outage Warning	
	25	Software Upgrade Failure Alarm	
	26	iButton Fault Warning	
	27	iButton Fault Alarm	
	28	Version Upgrade Available	
	29	Expansion Box Unsupported	
Tank	1	Tank Setup Data Warning	
	2	Tank Leak Alarm	
	3	Tank High Water Alarm	
	4	Tank Overfill Alarm	
	5	Tank Low Product Alarm	
	6	Tank Sudden Loss Alarm	
	7	Tank High Product Alarm	
	8	Tank Invalid Fuel Level Alarm	
	9	Tank Probe Out Alarm	
	10	Tank High Water Warning	
	11	Tank Delivery Needed Warning	
	12	Tank Maximum Product Alarm	
	13	Tank Gross Leak Test Fail Alarm	
	14	Tank Periodic Leak Test Fail Alarm	
	15	Tank Annual Leak Test Fail Alarm	
	16	Tank Periodic Test Needed Warning	
	17	Tank Annual Test Needed Warning	
	18	Tank Periodic Test Needed Alarm	
	19	Tank Annual Test Needed Alarm	
	20	Tank Leak Test Active	
	21	Tank No CSLD Idle Time Warning	
	22	Tank Siphon Break Active Warning	
	23	Tank CSLD Rate Increase Warning	



Alarm_Category	Data Array Offset	Description	TLS-450 Availability
	24	Tank AccuChart Calibration Warning	Version 2
	25	Tank HRM Reconciliation Warning	
	26	Tank HRM Reconciliation Alarm	
	27	Tank Cold Temperature Warning	
	28	Tank Missing Delivery Ticket Warning	Version 2
	29	Tank/Line Gross Leak Alarm	
	30	Delivery Density Warning	
	31	Density warning	Version 3
	32	Fuel Quality Alarm	Version 3
	33	Tank High Temperature Warning	
	34	Tank Low Temperature Warning	
	38	Density Offset Warning	Version 3
	Liquid Sensor	2	Liquid Sensor Setup Data Warning
3		Liquid Sensor Fuel Alarm	
4		Liquid Sensor Out Alarm	
5		Liquid Sensor Short Alarm	
6		Liquid Sensor Water Alarm	
7		Liquid Sensor Water Out Alarm	
8		Liquid Sensor High Liquid Alarm	
9		Liquid Sensor Low Liquid Alarm	
10	Liquid Sensor Liquid Warning		
Vapor Sensor	2	Vapor Sensor Setup Data Warning	
	3	Vapor Sensor Fuel Alarm	
	4	Vapor Sensor Out Alarm	
	5	Vapor Sensor Short Alarm	
	6	Vapor Sensor Water Alarm	
	7	Vapor Sensor Water Out Alarm	
Input	1	Input Setup Data Warning	
	2	Input Normal	
	3	Input Alarm	
	4	Generator Off	
	5	Generator On	
	6	Input Out Alarm	
Volumetric Line	1	VLLD Setup Data Warning	Obsolete
	2	VLLD Self Test Alarm	Obsolete
	3	VLLD Shutdown Alarm	Obsolete
	4	VLLD Leak Test Fail Alarm	Obsolete
	5	VLLD Selftest Invalid Warning	Obsolete
	6	VLLD Continuous Handle On Warning	Obsolete
	7	VLLD Gross Line Test Fail Alarm	Obsolete
	8	VLLD Gross Line Selftest Fail Alarm	Obsolete
	9	VLLD Gross Pump Test Fail Alarm	Obsolete
	10	VLLD Gross Pump Selftest Fail Alarm	Obsolete
	11	VLLD Periodic Test Needed Warning	Obsolete
	12	VLLD Annual Test Needed Warning	Obsolete
	13	VLLD Periodic Test Needed Alarm	Obsolete
	14	VLLD Annual Test Needed Alarm	Obsolete
	15	VLLD Periodic Line Test Fail Alarm	Obsolete
	16	VLLD Periodic Line Selftest Fail Alarm	Obsolete
	17	VLLD Periodic Pump Test Fail Alarm	Obsolete
	18	VLLD Periodic Pump Selftest Fail Alarm	Obsolete
	19	VLLD Annual Line Test Fail Alarm	Obsolete
	20	VLLD Annual Line Selftest Fail Alarm	Obsolete
	21	VLLD Annual Pump Test Fail Alarm	Obsolete
	22	VLLD Annual Pump Selftest Fail Alarm	Obsolete
	23	VLLD Pressure Warning	Obsolete
	24	VLLD Pressure Alarm	Obsolete

Alarm_Category	Data Array Offset	Description	TLS-450 Availability
	25	VLLD Gross Test Fault Alarm	Obsolete
	26	VLLD Periodic Test Fault Alarm	Obsolete
	27	VLLD Annual Test Fault Alarm	Obsolete
	28	VLLD Fuel Out Alarm	Obsolete
Groundwater Sensor	2	Groundwater Sensor Setup Data Warning	
	3	Groundwater Sensor Fuel Alarm	
	4	Groundwater Sensor Out Alarm	
	5	Groundwater Sensor Short Alarm	
	7	Groundwater Sensor Water Out Alarm	
Type-A Sensor	2	Type A Sensor Setup Data Warning	
	3	Type A Sensor Fuel Alarm	
	4	Type A Sensor Out Alarm	
	5	Type A Sensor Short Alarm	
	6	Type A Sensor Water Alarm	
Type-B Sensor	2	Type B Sensor Setup Data Warning	
	3	Type B Sensor Fuel Alarm	
	4	Type B Sensor Out Alarm	
	5	Type B Sensor Short Alarm	
	8	Type B Sensor High Liquid Alarm	
	10	Type B Sensor Liquid Warning	
Auto-Dial	1	Autodial Setup Data Warning	Obsolete
	2	Autodial Failed Alarm	Obsolete
	3	Autodial Service Report Warning	Obsolete
	4	Autodial Alarm Clear Warning	Obsolete
	5	Autodial Delivery Report Warning	Obsolete
Mech. Dispenser Elec. Dispenser	1	DIM Setup Data Warning	Version 2
	2	DIM Disabled Alarm	Version 2
	3	DIM Communication Failure Alarm	Version 2
	4	DIM Transaction Alarm	Version 2
	5	DIM Firmware Alarm	Version 2
Product	1	BIR Setup Data Warning	Version 2
	2	BIR Threshold Alarm	Version 2
	3	BIR Close Shift Warning	Obsolete
	4	BIR Close Daily Warning	Obsolete
Pressure Line	1	PLLD Setup Data Warning	
	2	PLLD Gross Test Fail Alarm	
	3	PLLD Annual Test Fail Alarm	
	4	PLLD Periodic Test Needed Warning	
	5	PLLD Periodic Test Needed Alarm	
	6	PLLD Sensor Open Alarm	
	7	PLLD High Pressure Alarm	Obsolete
	8	PLLD Shutdown Alarm	
	9	PLLD High Pressure Warning	Obsolete
	10	PLLD Continuous Handle On Warning	Obsolete
	11	PLLD Periodic Test Fail Alarm	
	12	PLLD Annual Test Needed Warning	
	13	PLLD Annual Test Needed Alarm	
	14	PLLD Low Pressure Alarm	
	15	PLLD Sensor Short Alarm	Obsolete
	16	PLLD Continuous Handle On Alarm	
	17	PLLD Fuel Out Alarm	
	18	PLLD Line Equipment Alarm	
	19	Gross Test Needed Alarm	Version 3

Alarm_Category	Data Array Offset	Description	TLS-450 Availability
<b>Wireless PLD (WPLLP)</b>	1	WPLLD Setup Data Warning	Obsolete
	2	WPLLD Gross Test Fail Alarm	Obsolete
	3	WPLLD Periodic Test Fail Alarm	Obsolete
	4	WPLLD Periodic Test Needed Warning	Obsolete
	5	WPLLD Periodic Test Needed Alarm	Obsolete
	6	WPLLD Sensor Open Alarm	Obsolete
	7	WPLLD Communications Alarm	Obsolete
	8	WPLLD Shutdown Alarm	Obsolete
	9	WPLLD Continuous Handle On Warning	Obsolete
	10	WPLLD Annual Test Fail Alarm	Obsolete
	11	WPLLD Annual Test Needed Warning	Obsolete
	12	WPLLD Annual Test Needed Alarm	Obsolete
	13	WPLLD High Pressure Warning	Obsolete
	14	WPLLD High Pressure Alarm	Obsolete
	15	WPLLD Sensor Short Alarm	Obsolete
	16	WPLLD Continuous Handle On Alarm	Obsolete
	17	WPLLD Fuel Out Alarm	Obsolete
	18	WPLLD Line Equipment Alarm	Obsolete
<b>External</b>	1	Externally Detected Communication Alarm	
	2	Communications - Data Reception Timeout	
	3	Communications - Failed Checksum	
	4	Communications - Parity Error	
	5	Modem - Line Busy	
	6	Modem - No Answer	
	7	Modem - No Carrier	
	8	Modem - No Dial Tone	
	9	Modem - Modem Error	
	10	Modem - Modem Not Responding	
	11	Modem - Port Not Available	
	12	Polling - Could Not Update Queue	
	13	Polling - Invalid Data Type Requested	
<b>Relay</b>	1	Relay Setup Data Warning	
	2	Relay Out Alarm	
<b>Smart Sensor Alarm 28</b>	1	Smart Sensor Setup Data Warning	
	2	Smart Sensor Communication Alarm	
	3	Smart Sensor Fault Alarm	
	4	Smart Sensor Fuel Warning	
	5	Smart Sensor Fuel Alarm	
	6	Smart Sensor Water Warning	
	7	Smart Sensor Water Alarm	
	8	Smart Sensor High Liquid Warning	
	9	Smart Sensor High Liquid Alarm	
	10	Smart Sensor Low Liquid Warning	
	11	Smart Sensor Low Liquid Alarm	
	12	Smart Sensor Temperature Warning	
	13	Smart Sensor Relay Active	
	14	Smart Sensor Install Alarm	
	15	Smart Sensor Sensor Fault Warning	
	16	Smart Sensor Vacuum Warning	
	17	Smart Sensor No Vacuum Warning	
<b>Modbus Alarm 29</b>	1	Improper Setup Alarm	
	2	Communication Loss Alarm	

Alarm_Category	Data Array Offset	Description	TLS-450 Availability
<b>ISD Site Alarm 30</b>	1	Stage 1 Transfer Monitoring Failure Warning	
	2	Containment Monitoring Gross Failure Warning	
	3	Containment Monitoring Gross Failure Alarm	
	4	Containment Monitoring Degradation Failure Warning	
	5	Containment Monitoring Degradation Failure Alarm	
	6	Containment Monitoring CVLD Failure Warning	
	7	Containment Monitoring CVLD Failure Alarm	
	8	Vapor Processor Over Pressure Failure Warning	
	9	Vapor Processor Over Pressure Failure Alarm	
	10	Vapor Processor Status Test Warning	
	11	Vapor Processor Status Test Alarm	
	12	Missing Relay Setup Alarm	
	13	Missing Hose Setup Alarm	
	14	Missing Tank Setup Alarm	
	15	Missing Vapor Flow Meter Alarm	
	16	Missing Vapor Pressure Sensor Alarm	
	17	Missing Vapor Pressure Input Alarm	
	18	Setup Fail Warning	
	19	Setup Fail Alarm	
	20	Sensor Out Warning	
	21	Sensor Out Alarm	
	22	PC-ISD Offline	
<b>ISD Hose Alarm 31</b>	1	Collection Monitoring Gross Failure Warning	
	2	Collection Monitoring Gross Failure Alarm	
	3	Collection Monitoring Degradation Failure Warning	
	4	Collection Monitoring Degradation Failure Alarm	
	5	Flow Performance Hose Blockage Failure Warning	
	6	Flow Performance Hose Blockage Failure Alarm	
	7	Vapor Flow Meter Setup Alarm	
<b>ISD Vapor Flow Meter Alarm 32</b>	1	Locked Rotor Alarm	
	2	VFM Setup Data Warning	
	3	VFM Device Out Alarm	
<b>PMC Alarm 33</b>	1	Vapor Processor Run Time Fault Warning	
	2	Processor Monitoring Effluent Emissions Failure Warning	
	3	Processor Monitoring Effluent Emissions Failure Alarm	
	4	Processor Monitoring Over Pressure Failure Warning	
	5	Processor Monitoring Over Pressure Failure Alarm	
	6	Processor Monitoring Duty Cycle Failure Warning	
	7	Processor Monitoring Duty Cycle Failure Alarm	
	8	PMC(Stand alone mode only) Setup Warning	
	9	PMC Out Alarm	
<b>Pump Relay Monitor Alarm 34</b>	1	Setup Data Warning	
	2	Pump Relay Alarm	

Alarm_Category	Data Array Offset	Description	TLS-450 Availability
<b>MAG Sensor</b>	2	MAG Sensor Setup Data Warning	
	3	MAG Sensor Communicaiton Alarm	
	4	MAG Sensor Fault Alarm	
	5	MAG Sensor Fuel Warning	
	6	MAG Sensor Fuel Alarm	
	7	MAG Sensor Water Warning	
	8	MAG Sensor Water Alarm	
	9	MAG Sensor High Liquid Warning	
	10	MAG Sensor High Liquid Alarm	
	11	MAG Sensor Low Liquid Warning	
	12	MAG Sensor Low Liquid Alarm	
	13	MAG Sensor Temperature Warning	
	14	MAG Sensor Relay Active	
	15	MAG Sensor Install Alarm	
<b>Line Pressure Sensor</b>	1	LPR Sensor Setup Data Warning	
	2	LPR Sensor Communication Alarm	
<b>Printer</b>	1	Printer Out of Paper	
	2	Printer Error	
<b>Pump</b>	1	Pump Setup Data	
	2	Pump Out Alarm	
	3	Stuck Relay or Continuous Pump	
<b>Line</b>	1	Line Setup Data Warning	
	2	Line Out Alarm	
<b>Communication</b>	1	Communication Setup Data Warning	
	2	Communication Setup Data Alarm (future)	
	3	Communication Warning	
<b>Contact</b>	1	Autodial Setup Data Warning	
	2	Autodial Failed Alarm	
	3	Autodial Service Report Warning	Future
	4	Autodial Alarm Clear Warning	Obsolete
	5	Autodial Delivery Report Warning	Obsolete
	6	Autodial No DialTone Alarm	Future
	7	Autodial Fax Failed Alarm	
	8	Email Failed	Future
	9	SMS Failed	
<b>Auto Event</b>	1	Auto Event Setup Data Warning	
<b>VMCI Dispenser Interface 35</b>	1	VMCI Setup Data Warning	
	2	VMCI DIM Disabled	
	3	VMCI DIM Comm Timeout	
<b>VMC Alarm 36</b>	1	VMC Comm timeout	obsolete
	2	Meter Not Connected	
	3	FP Shutdown Warning	
	4	FP Shutdown Alarm	
	5	Setup Data Warning	
<b>VPM Alarm 37</b>	1	Gross Over-Pressure Test Warning	
	2	VPM Gross Over-Pressure Test Failure Warning	
	3	VPM Gross Over-Pressure Test Failure Alarm	
	4	VPM Degradation Over-Pressure Test Failure Warning	
	5	VPM Degradation Over-Pressure Test Failure Alarm	
	6	VPM Sensor Test Failure Warning	
	7	VPM Sensor Test Failure Alarm	
	8	VPM Setup Failure Warning	
	9	VPM Sensor Out Failure Warning	
	10	VPM Sensor Out Failure Alarm	

Appendix C.3 Data Type and Required Lengths

The following table provides a list of possible values for the data type parameter as well as the minimum value that the length parameter should be set to for each Map Descriptor of that data type.

Data Type	TLS-350	TLS-450
Configuration	See Example	N/A
In-Tank Inventory	9	9
Misc.	See examples	N/A
In-Tank Delivery	14	14
System Reset	16	N/A
Clear Power Reset	16	N/A
Remote Alarm Reset	16	16
Confirm Clear	16	N/A
Clear Delivery Reports	16	N/A
Start In-Tank Leak Detect Test	16	16
Stop In-Tank Leak Detect Test	16	16
Delete CSLD Rate Table	16	16
Start P-Line Leak Detect Test	16	16
Stop In-Tank Leak Detect Test	16	16
Start WPLLD Leak Detect Test	16	N/A
Stop WPLLD Leak Detect Test	16	N/A
System status	17	17

Appendix C.4 Module Types

00 - Not used	0A - Four Probe w/ Ground Temp Module
01 - FourProbe Module	0B - Groundwater Sensor Module
02 - Vapor Sensor Module	0C - Type A Sensor Module
03 - Liquid Sensor Module	0D - Remote Display Module
04 - FourRelay Module	
05 - I/O Combo Module	
06 - Printer Module	
07 - RS-232 Module	
08 - Modem Module	
09 - Volumetric Line Leak Module	
10 - Type B Sensor Module	1A - Pressure Line Leak Sensor Module
11 - Universal Sensor Module	1B - Pressure Line Leak Controller Module
12 - Fax/Modem (1785) Module	1D - Remote Printer Module
13 - Remote/Local Printer Module	1E - External Fax/Modem Module
14 - Pump Sensor Module	1F - RS-485 Module
15 - European RS-232 Module	
17 - EightProbe Module	
18 - Mechanical Dispenser Interface Module	
19 - Electronic Dispenser Interface Module	
20 - Wireless PLLD AC Interface Module	
21 - Wireless PLLD Communications Module	
22 - Wireless PLLD Controller Module	
23 - Hughes Satellite J-Box Module	
24 - Fax/Modem (1786) Module	
25 - Serial Satellite Module	
26 - Three Probe / Three Liquid Sensor Module	
27 - Three PLLD Sensor Module	

Appendix C.5 Error Messages

Error	Action Required
VRoot:#1 FYI. The mapDesc called <%s> is too short. <sup>5</sup>	The length of the Map Descriptor used to expose driver statistics is too short. Set the length to at least 600.
VRoot:#2 FYI. You could have used a mapDesc called <%s> to expose diagnostic info.	You can safely ignore this message. It is a prompt. Refer to <a href="#">Appendix C.6</a> .
*VRoot:#3 Err. Data Type=%d is unknown. Data will be discarded.	The driver has encountered a message reporting an alarm for an equipment category/data type the driver does not recognize. Refer to FieldServer technical support.
VRoot:#4 FYI. If there is more than one VRoot node then connect each node to a dedicated port	You may ignore this message if only one Veeder-Root node is connected to the FieldServer. If more than one node is connected then each node must be connected to a separate port.
VRoot:#5 Err. Data Type invalid for this driver. Md=<%s> <sup>5</sup>	The Data types must be spelled, spaced and punctuated exactly as in <a href="#">Section 5.3.2</a> .
VRoot:#6 Err. No Default Poll Function for this data type. Md= <%s> <sup>5</sup>	Some data types require an additional Map Descriptor parameter 'VEED_Function' to be specified.
VRoot:#7 Err. Length too short. Rqd=%d. Md=<%s> <sup>5</sup>	The message reports the offending Map Descriptor and the number of array elements required. Adjust the length parameter accordingly. Ensure that the new length coupled with the offset fits in the array size.
VRoot:#11 Err. Command 0x54 cannot specify all tanks <sup>5</sup>	For the Data Type (or Veed_Function) specified the address may not be set to zero. You need one Map Descriptor per tank/sensor/input/device.
VRoot:#12 Err. Command 0x54. Bad confirmation code.	Refer to FieldServer technical support.
*VRoot:#13 Err. Device Rejected message. Md=<%s>	<p>This message is generated the first time that the Error Statistic 'Function Error' is produced. This error can arise in several ways.</p> <p>The firmware version of the Veeder-Root device may not support the poll generated by the Map Descriptor. Refer to <a href="#">Appendix C.1</a>.</p> <p>The Veeder-Root device may not have the tank/sensor/device specified or the message received by the Veeder-Root device is corrupted. Check the devices configured against the address specified in the Map Descriptor.</p>
*VRoot:#16 Err. Array too short to store. Md=<%s> Rqd=%d	<p>When this error is produced incoming data is being discarded and alarm or other data will not be updated. There are a few variations on this message. Some do not report the Rqd length. This message is produced as a run-time error. It may arise from a configuration error that has not been corrected. Check for Error #7 messages. If there are any correct the errors by editing the CSV file. Then reset the FieldServer. If the driver is still producing error 16 then you should report this to FieldServer support. Provide a copy of your configuration file and a port log to assist in the diagnosis of this error.</p>

<sup>5</sup> Download the CSV file, make the relevant changes, then upload the file and cycle power to the FieldServer.



Error	Action Required
*VRoot:#17 Err. Array too short to store. Md= <%s> ByteArray	This error is similar to #16 except that it applies to the array named in the DA_Byte_Name parameter for the Map Descriptor.
*VRoot:#18 Err. Array too short to store. Md= <%s> Float Array	This error is similar to #16 except that it applies to the array named in the DA_Float_Name parameter for the Map Descriptor.
VRoot:#19 Err. Cant process msg type= %x	You cannot take any corrective action to eliminate this error. Report the message to FieldServer support. It will assist in the diagnosis of the error if you can take a port log and provide a copy of your CSV file.
*VRoot:#20 FYI. Incoming data is being abandoned. Func= %x DT= <%s> Addr=%d	This message is a warning. It indicates that a response to a poll contains data for which a Map Descriptor cannot be found to store the data. For example: The response to poll for System Status returns an alarm for Liquid Sensor #3 but you have not defined a Map Descriptor for Liquid sensor #3. You may be able to use the Data Type and the Address to determine what kind of Map Descriptor is required. If, however, you are satisfied that you have Map Descriptors for the data of interest to you then you may safely ignore this message.
*VRoot:#21 Err. Md=<%s> not bound to a port. Can't be used.	Read the notes for Error #4 to see how to correct this problem.
Vroot:#22 FYI. Config reported zero modules.	You may ignore this message. The Veeder-Root device reported zero configured modules in response to a configuration enquiry.
*VROOT:#23 Err. Address= 0 invalid for this command. Md= <%s> <sup>6</sup>	Set the address to a positive number corresponding to the tank/sensor/input/device whose data you are polling for.
*VROOT:#24 Err. Function=%x not supported. Md= <%s> <sup>6</sup>	Check the data type's spelling spacing and punctuation. If the Veed_Function parameter has been specified in the Map Descriptor, check that the function is supported by the driver and that it is specified correctly. Refer to <b>Section 5.3</b> .
VROOT:#25 FYI. Node=<%s> No password. Is security disabled on panel?	This message may be safely ignored. It does not indicate an error. This message is printed once for each node which does not have a password. This message provides confirmation that your configuration is not using a password and suggests that you check the panel configuration for the corresponding node to ensure that the security feature has been disabled. Additional information is provided in <b>Appendix A.9</b> .
VROOT:#26 FYI. Node=<%s> Password=<%s>. Is security enabled on panel?	

<sup>6</sup> Download the CSV file, make the relevant changes, then upload the file and cycle power to the FieldServer.



Appendix C.6 Driver Stats

In addition to the standard FieldServer communication statistics described in the FieldServer Configuration Manual, Veeder-Root Driver can also expose some driver statistics by writing data to a Data Array. A special Map Descriptor named “vroot-stats” is required.

The following example shows how this special Map Descriptor can be configured. This section of text may be copied directly into your CSV file.

Nodes					
Node_Name		, Protocol			
null_node		, VRoot			
Data_Arrays					
Data_Array_Name		, Data_Format		, Data_Array_Length	
VROOT_STATS		, UINT32		, 1000	
Map_Descriptors					
Map_Descriptor_Name		, Data_Array_Name	, Node_Name	, Length	, Function , Data_Type
VRoot-stats		, VROOT_STATS	, Null_Node	, 1000	, Rdbc , Stats

The driver uses the Data Array VROOT\_STATS (in this example) to store driver specific statistics. Only one of these Map Descriptors may be specified per FieldServer.

The driver stores the following data:

- 1 VEED\_MASTER\_SENDS\_MSG
- 2 VEED\_MASTER\_SENDS\_BYTES
- 3 VEED\_MASTER\_TIMEOUT
- 4 VEED\_MASTER\_STREAMING
- 5 VEED\_MASTER\_RCVS\_NAK
- 6 VEED\_MASTER\_RCVS\_CHECKSUM
- 7 VEED\_MASTER\_RCVS\_PROTOCOL
- 8 VEED\_MASTER\_COMPLETE\_ERR
- 9 VEED\_MASTER\_RCVS\_MSG
- 10 VEED\_MASTER\_RCVS\_BYTES
- 11 VEED\_MASTER\_IC\_TIMEOUT
- 12 VEED\_MASTER\_SEND\_BAD\_MSG
- 13 VEED\_STAT\_MSG\_IGNORED
- 14 VEED\_MASTER\_RCV\_BAD\_FUNC\_RESPONSE