



GE Lighting Controls

INSTALLATION INSTRUCTIONS

Model #

WIR-10-DR-G-D-W
WIR-10-DR-G-D-V
WIR-10-DR-G-D-A
WIR-10-DR-G-D-G
WIR-10-DR-G-D-B



RoHS

Passive Infrared Dual-Relay Wallbox Occupancy Sensor (Ground Required)

General Information

- Read all instructions on both sides of this sheet first.
- Plan all component locations carefully.
- For use with 120/277 VAC only
- Install in accordance with ALL local codes.
- For indoor use only.

Specifications

Technology: Passive Infrared (PIR)

Coverage: Major Motion - 1000 sq. ft.
Minor Motion - 300 sq. ft.

Electrical Ratings(per relay):

- 120 VAC:**
- Incandescent/Tungsten - Max. load: 6.7 amps, 800W, 50/60 Hz
 - Fluorescent/Ballast - Max. load: 10 amps, 1200W, 50/60 Hz
 - Motor Load: ¼ HP @ 125 VAC

Light Level Sensing: 0 to 200 foot-candles

Housing:

- Durable, injection-molded housing. Polycarbonate resin complies with UL94V0.

277 VAC:

- Fluorescent/Ballast - Max. load: 9.8 amps, 2700W, 50/60 Hz
- No minimum load requirements

Size:

- **Mounting Plate Dimensions:** 4.195" H x 1.732" W (106.553 mm x 44 mm)
- **Product Housing Dimensions:** 2.618" H x 1.752" W x 1.9" D (66.5 mm x 44.5 mm x 48.26 mm)

Time Delays: Self-Adjusting, 15 seconds/test (10 min Auto), Selectable 5, 15, 30 minutes

LED Indicators: Red indicates PIR detection

Operating Environment:

- Temperature: 32° F - 104° F (0° C - 40° C)
- Relative Humidity: 20% to 90% non-condensing
- For indoor use only

Operating Modes:

- Automatic ON/Automatic OFF
- Manual ON/Automatic OFF

Description

The WIR-10-DR-G-D Occupancy Sensing Wall Switch is a Passive Infrared (PIR) motion sensing lighting control and conventional Wall Switch all-in-one, used for energy savings and convenience. PIR Technology

The sensor's segmented lens divides the field of view into sensor zones, and detects the changes in temperature that are created when a person, or part of a person as small as a hand, passes into or out of a sensor zone.

The WIR-10-DR-G-D allows the control of two separate loads with one occupancy sensor switch. Energy Saver Mode - Either or both loads may be configured to turn ON manually. The default setting for the second load is Manual ON. This ensures the Wall Switch only activates one load. If both loads are on when the sensor times-out, only the primary load will be activated. If the lights were shut OFF manually, the unit will activate the primary load only.

In Automatic ON Mode, the lights turn ON automatically when a person enters the room. In Manual ON Mode, the lights are turned ON by pressing the pushbutton. In either mode, the lights stay ON as long as the sensor detects motion in the room. When the room is vacated, the lights turn OFF automatically after a preset Time Delay interval.

The sensor includes self-adaptive technology that continually adjusts to conditions by adjusting sensitivity and Time Delay in Real-time. By adjusting sensitivity and Time Delay automatically, the sensor is maximizing the potential energy savings that are available in the particular application.

The Daylighting feature prevents lights from turning ON, when the room is adequately illuminated by natural light.

Walk-Through feature maximizes energy savings by not leaving the lights ON after a momentary occupancy. The sensor will switch the lights ON when it detects a person entering the area. If the sensor does not continue to detect motion 20 seconds following the initial activation, it will automatically go to a shorter 2 minute Time Delay.

Coverage

The WIR-10-DR-G-D is designed for offices up to 300 square feet. Coverage testing has been performed according to the NEMA WD7 Guideline.

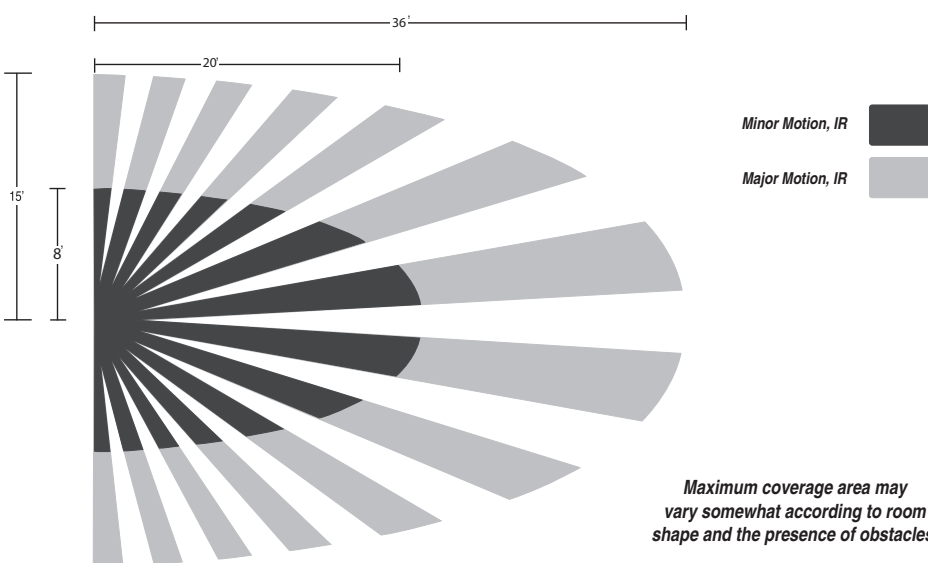

Location

When installing the WIR-10-DR-G-D in a new junction box, choose the switch location carefully to provide optimum coverage of the occupied area. When replacing an existing Wall Switch, bear in mind that there must be a clear Line-of-sight between the sensor and the area to be covered. Avoid pointing the WIR-10-DR-G-D directly into the hallway where it may detect passers-by.

Installation

NOTE: Before you begin, read these instructions completely and carefully.



The WIR-10-DR-G-D can be installed in any standard single gang box. It may be installed in the same manner as an ordinary Wall Switch.

- Wire the WIR-10-DR-G-D as described in the wiring section.
- Mount the WIR-10-DR-G-D in the junction box.

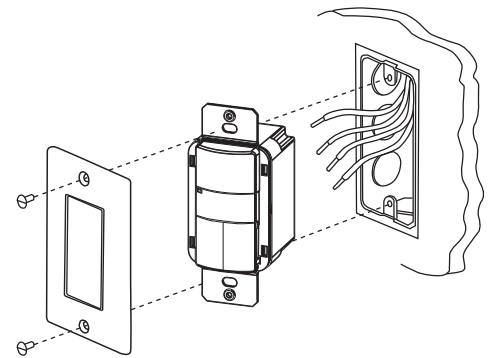

Wiring

CAUTION: Before installing or performing any service on a GE system, the power **MUST** be turned off at the branch circuit breaker. According to NEC 240-83(d), if the branch circuit breaker is used as the main switch for a fluorescent lighting circuit, the circuit breaker should be marked "SWD." All installations should be in compliance with the National Electric Code and all state and local codes.

NOTE REGARDING COMPACT FLUORESCENT LAMPS: The life of some compact fluorescent lamps (CFLs) is shortened by frequent automatic or manual switching. Check with CFL and ballast manufacturer to determine the effects of cycling.

1. Make sure power is turned off at the branch circuit breaker.
2. Wire units as shown in wiring diagrams per applicable voltage requirements.
3. Mount unit to Wall Box.
4. Turn power back ON at the branch circuit breaker and wait 2 minutes for the unit to stabilize.
5. Make necessary adjustments. (See Checkout and Adjustments section)
6. Install Wall Switch plate.

Wiring Diagram 1: 120/277 VAC dual level single circuit wiring diagram

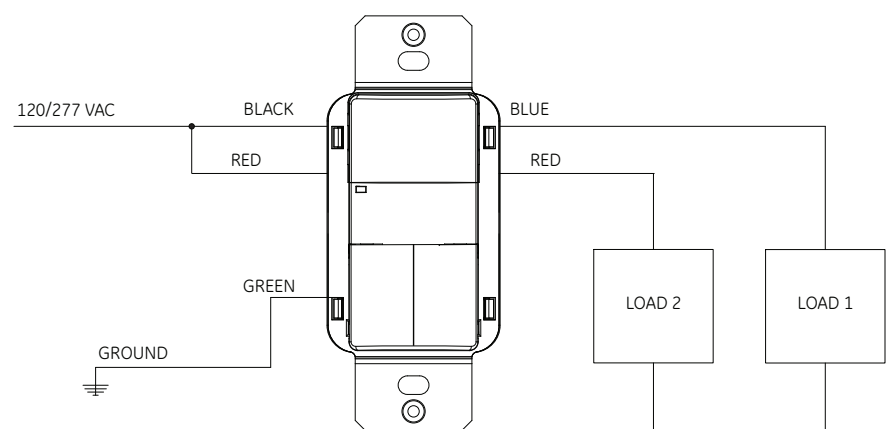
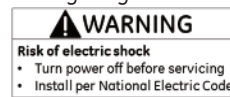

Wiring Diagram 2: 120/277 VAC dual level dual circuit wiring diagram

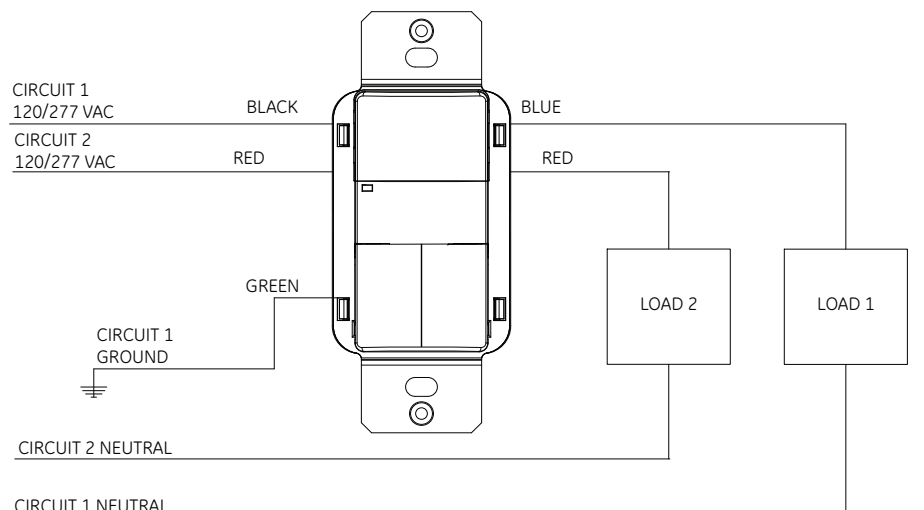

Wiring Diagram 3: 120/277 VAC dual level single circuit three-way wiring diagram

WARNING
 Risk of electric shock
 • Turn power off before servicing
 • Install per National Electric Code

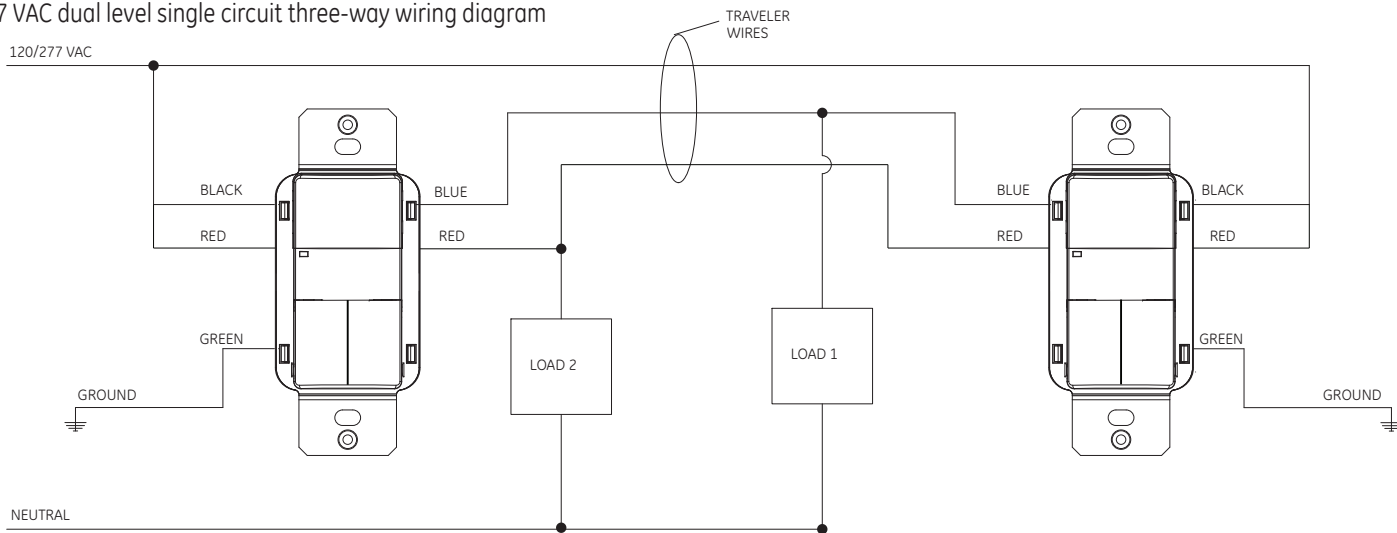

THREE-WAY WIRING DIAGRAM:
 LIGHTS WILL TURN OFF, WHEN UNIT THAT WAS TURNED ON LAST AND/OR DETECTED MOTION LAST TIMES-OUT.

DIP Switch Settings

DIP Switch	Time Delay		Activation		PIR Sensitivity	Walk-Through Mode	Not Used	Override	Not Used	Not Used	Daylighting	
	1	2	Relay 1	Relay 2							Relay 1	Relay 2
Auto*	▼	▼	Auto	Auto	Full	Disable		Disable			Disable	Disable
5 Minutes	▲	▲	Manual	Manual	50%	Enable		Enable			Enable	Enable
15 Minutes	▲	▲										
30 Minutes	▲	▲										

*Self-Adjusts to 10 min. user mode

Default =

Checkout and Adjustment

Adjustments should be made with the HVAC system on so that the installer will be able to detect the effect of airflow on the operation of the WIR-10-DR-G-D. Use only insulated tools to make adjustments. Immediately after applying power to the lighting circuit, wait approximately two minutes for the switch to power up and stabilize.

Self-Adjust

The sensor is shipped in self-adjust mode. This applies to Time Delay and PIR sensitivity. In preparation for the Installer Test, the Time Delay is set to 15 seconds, after the sensor is installed, powered on and has stabilized, the unit will Time-out 15 seconds after the last motion detected. Coverage and sensitivity can be confirmed by watching the Red (PIR) indicator LED on the front of the sensor, while moving around the room.

- Walk around the room and monitor LEDs.
- Stand in different parts of the room and wave your hands. LED should only turn on for one second with each motion. (If LED does not turn on, go to Installer Adjustments - Sensitivity Adjustment Section)
- Stand still three to four feet away from sensor for five seconds. LED should not turn on. (If LED turns on, go to Installer Adjustments - Sensitivity Adjustments section)
- Walk outside the room and wait 15 seconds for the lights to turn off. (If lights do not turn off go to Installer Adjustments Section)
- Re-enter the room to activate sensor. (If lights do not turn on go to Troubleshooting Section)
- At this point you can exit the room and let the sensor Time-out. When the sensor times-out and is off for five minutes, the unit will go to a 10 minute Time Delay user mode setting.

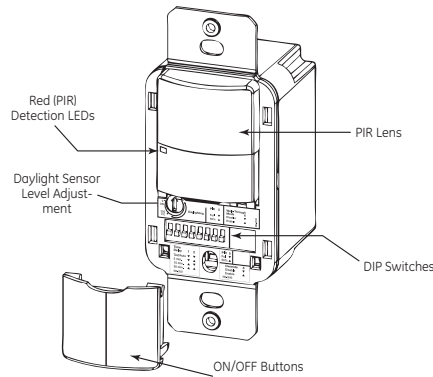

Note: To place into Test Mode, toggle DIP Switch 8 out of its current position, wait 3 seconds, and then back into its original position.

Installer Adjustments

PIR Sensitivity

- Stand in different areas of the room and wave your hands.
- If the Red LED does not turn on, check for any obstructions.
- Stand still three to four feet away from sensor for five seconds. LED should not turn on.
- If Red LED turns on without motion or is constantly on adjust PIR sensitivity to 50 % by moving DIP Switch 5 up.

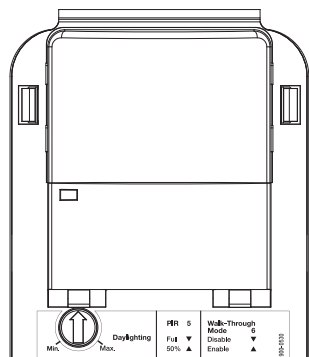

ON/OFF Disabled Feature

- ON/OFF Button Disable Option - When selected this option disables the ON/OFF button and sensor becomes automatic only control regardless of the setting for automatic or manual activation. This feature will not allow someone to turn light(s) OFF via the Pushbutton while people are in common areas such as restroom, break room, and copy room areas.

Field-of-view outside the space

- Adjust PIR sensitivity to 50 % by moving DIP Switch 5 up.
- Use non-reflective tape strips to cover the portions of the sensor lens that view outside the space.

Daylight Adjustments

The daylighting feature prevents the lights from turning ON when the room is adequately illuminated by natural light. If there is enough light in the room regardless of occupancy, the sensor will hold the lights OFF. If there is not enough light in the room, the sensor will allow the lights to turn ON when occupied. The sensor will not allow the daylighting feature to turn the load OFF until the space is vacant or the light level rises above the setpoint and the Time Delay expires. While in Manual Activation Mode, if someone attempts to turn the load ON and there is sufficient daylight available the Daylighting feature will hold the lights OFF.

Set the light level when the ambient light is at the level where no artificial light is needed. If this feature is not needed, leave the light level at maximum (fully CW).

- With the load(s) ON, put the sensor into Test Mode. To place into Test Mode, toggle DIP Switch 8 out of its current position, wait 3 seconds and then back in to its original position.
- Set the Light level to minimum (fully CCW).
- Let the sensor Time-out so lights are OFF. Enter the space and lights should remain OFF.
- Make sure not to block the sensor from the daylight source and adjust the light level potentiometer CW in small increments. (Pause 5 seconds between each adjustment)
- Once the lights are ON, the load connected to the sensor will not turn ON if light levels are above the current illumination.

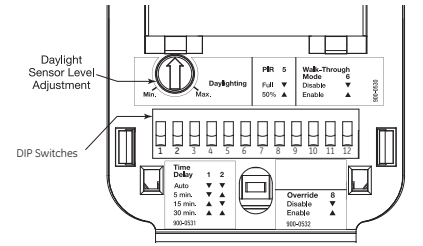

Time Delay Adjustments

People who remain very still for long periods of time may need a longer Time Delay than the default setting of 10 minutes. As long as the self-adjusting feature is enabled, the switch will respond to each pair of False-offs with no normal OFF in between, by alternately making slight adjustments to either Time Delay (by 2 minute increments) or sensitivity, so there should be no need for manual adjustment. If manual adjustment is desired, refer to Time Delay settings in DIP Switch Legend.

Reset sensor Time Delay to factory settings by moving DIP Switches 1 and 2 down. (If DIP Switches 1 and 2 are already down, toggle DIP Switch 1 out of its current position, wait 3 seconds, and then back to its original position)

Override

The override setting allows the sensor to operate as a service switch in the unlikely event of failure.

- Move DIP Switch 8 up.
- The Pushbutton can be used to manually turn lights ON or OFF.

Troubleshooting

Issue	Possible Causes	Suggestions
Lights Will Not Turn ON automatically	Sensor is in Manual ON mode	Press Pushbutton. If Auto Mode is desired change Activation Mode to Auto.
	Sensor was turned OFF manually. If the Sensor was turned OFF manually before the Time Delay expired, lights will remain OFF for the remainder of the Time Delay.	Press the Pushbutton to turn the lights back ON.
	Daylight Feature Enabled	If all lights are required to turn ON adjust daylight potentiometer.
	Power interruption	Check incoming voltage and/or wiring.
Lights Will Not Turn ON manually	Daylight Feature Enabled	If all lights are required to turn ON adjust daylight potentiometer.
	Power interruption	Check incoming voltage and/or wiring.
If lights will still not turn ON, set sensor to override mode and call Technical Services at 1-877-584-2685		
Lights Will Not Turn OFF automatically	Override	Make sure sensor is not in Override Mode (DIP Switch 8 up).
	Self-Adjust	If sensor is in Self-Adjust Mode, it may be possible for the unit to have increased the Time Delay to a 30 minute delay. If the lights do not turn OFF after 30 minutes follow next step.
	30 Minute Delay	Maximum Time Delay is 30 Minutes. Check DIP Switches to verify DIP Switch settings. If lights do not turn OFF at the set Time Delay, check next step.
	PIR activated by heat source other than occupant	Move DIP Switch 5 up.
Lights Will Not Turn OFF manually		Call Technical Services
If lights will still not turn ON, set sensor to override mode and call Technical Services at 1-877-584-2685		

Limited Warranty

This product is warranted to be free from defects in material and workmanship and shall conform to and perform in accordance with Seller's written specifications for a period of five (5) years from date of shipment for all occupancy sensors. We guarantee the performance of our product to specifications or your money back. This warranty will be limited to the repair or replacement, at Seller's discretion, of any such goods found to be defective, upon their authorized return to Seller. This limited warranty does not apply if the goods have been damaged by accident, abuse, misuse, modification or misapplication, by damage during shipment or by improper service. There are no warranties, which extend beyond the hereinabove-limited warranty, INCLUDING, BUT NOT LIMITED TO, THE IMPLIED WARRANTY OF MERCHANTABILITY AND THE IMPLIED WARRANTY OF FITNESS. No employee, agent, dealer, or other person is authorized to give any warranties on behalf of the Seller or to assume for the Seller any other liability in connection with any of its goods except in writing and signed by the Seller. The Seller makes no representation that the goods comply with any present or future federal, state or local regulation or ordinance. Compliance is the Buyer's responsibility. The use of the Seller's goods should be in accordance with the provision of the National Electrical Code, UL and/or other industry or military standards that are pertinent to the particular end use. Installation or use not in accordance with these codes and standards could be hazardous.