



FieldServer
FS-8700-51 United Power FIM
Driver Manual
(Supplement to the FieldServer Instruction Manual)

APPLICABILITY & EFFECTIVITY

Effective for all systems manufactured after November 2015

Driver Version: 1.00
Document Revision: 0

Contact Information:

Thank you for purchasing the FieldServer.

Please call us for Technical support of the FieldServer product.

Contact Information:

Sierra Monitor Corporation
1991 Tarob Court
Milpitas, CA 95035

Contact number:
+1 408 262-6611
+1 800 727-4377

Email: info@sierramonitor.com

Website: www.sierramonitor.com

TABLE OF CONTENTS

- 1 United power fim Description..... 4**
- 2 Driver Scope of Supply 5**
 - 2.1 Supplied by Sierra Monitor Corporation for this driver 5
 - 2.2 Provided by the Supplier of 3rd Party Equipment..... 5
 - 2.2.1 *Required 3rd Party Hardware*..... 5
- 3 Hardware Connections..... 6**
 - 3.1 Hardware Connection Tips / Hints 6
- 4 Configuring the FieldServer as a United Power FIM Client 7**
 - 4.1 Data Arrays/Descriptors 7
 - 4.2 Client Side Connection Descriptions 8
 - 4.3 Client Side Node Descriptors 8
 - 4.4 Client Side Map Descriptors 9
 - 4.4.1 *FieldServer Related Map Descriptor Parameters* 9
 - 4.4.2 *Driver Related Map Descriptor Parameters* 9
 - 4.4.3 *Timing Parameters* 9
 - 4.4.4 *Map Descriptor Example*..... 10
- 5 Configuring the FieldServer as a United Power FIM Server..... 11**
 - 5.1 Server Side Connection Descriptors 11
 - 5.2 Server Side Node Descriptors 12
 - 5.3 Server Side Map Descriptors..... 12
 - 5.3.1 *FieldServer Specific Map Descriptor Parameters* 12
 - 5.3.2 *Driver Specific Map Descriptor Parameters* 12
 - 5.3.3 *Map Descriptor Example*..... 13

LIST OF FIGURES

- Figure 1 - Connection Diagram.....6

1 UNITED POWER FIM DESCRIPTION

The United Power FIM driver allows the FieldServer to transfer data to and from devices over RS-232 (with RS422/RS485/RS232 converter) using United Power FIM protocol. The FieldServer can emulate either a Server or Client.

The FIM client driver allows for the polling of a FIM module to gather operational data of a connected UPS (Uninterruptable Power Supply).

The FIM server driver emulates a FIM module and can be used to test a FIM module client driver.

A FIM module can be polled for both analogue and digital data.

The protocol works over a multidrop 4-wire RS-485 line allowing for multiple FIM modules on the same communications line. Every FIM module has to be manually set to a unique address. The addresses used on a line must be all even or all odd (e.g. 2, 4, 6... or 1, 3, 5...). The reason for this addressing scheme is that analogue data is polled by using the exact address in the poll message whereas digital data is polled for by using the exact address plus one. Communication conflicts will exist on a line if one or more FIM modules are numbered consecutively.

Max Nodes Supported

FieldServer Mode	Nodes	Comments
Client	1	Only 1 client node allowed on multidrop systems
Server	128	Up to 128 FIM modules can be emulated, but this may be limited due to electrical loading

2 DRIVER SCOPE OF SUPPLY

2.1 Supplied by Sierra Monitor Corporation for this driver

Sierra Monitor Corporation PART #	Description
FS-8700-51	Driver Manual

2.2 Provided by the Supplier of 3rd Party Equipment

2.2.1 Required 3rd Party Hardware

FIM module addresses must be set up correctly. Refer to manufacturer's setup instructions.

3 HARDWARE CONNECTIONS

The FieldServer is connected to the FIM module as shown in the connection drawing below. Configure the FIM module according to Manufacturer's instructions.

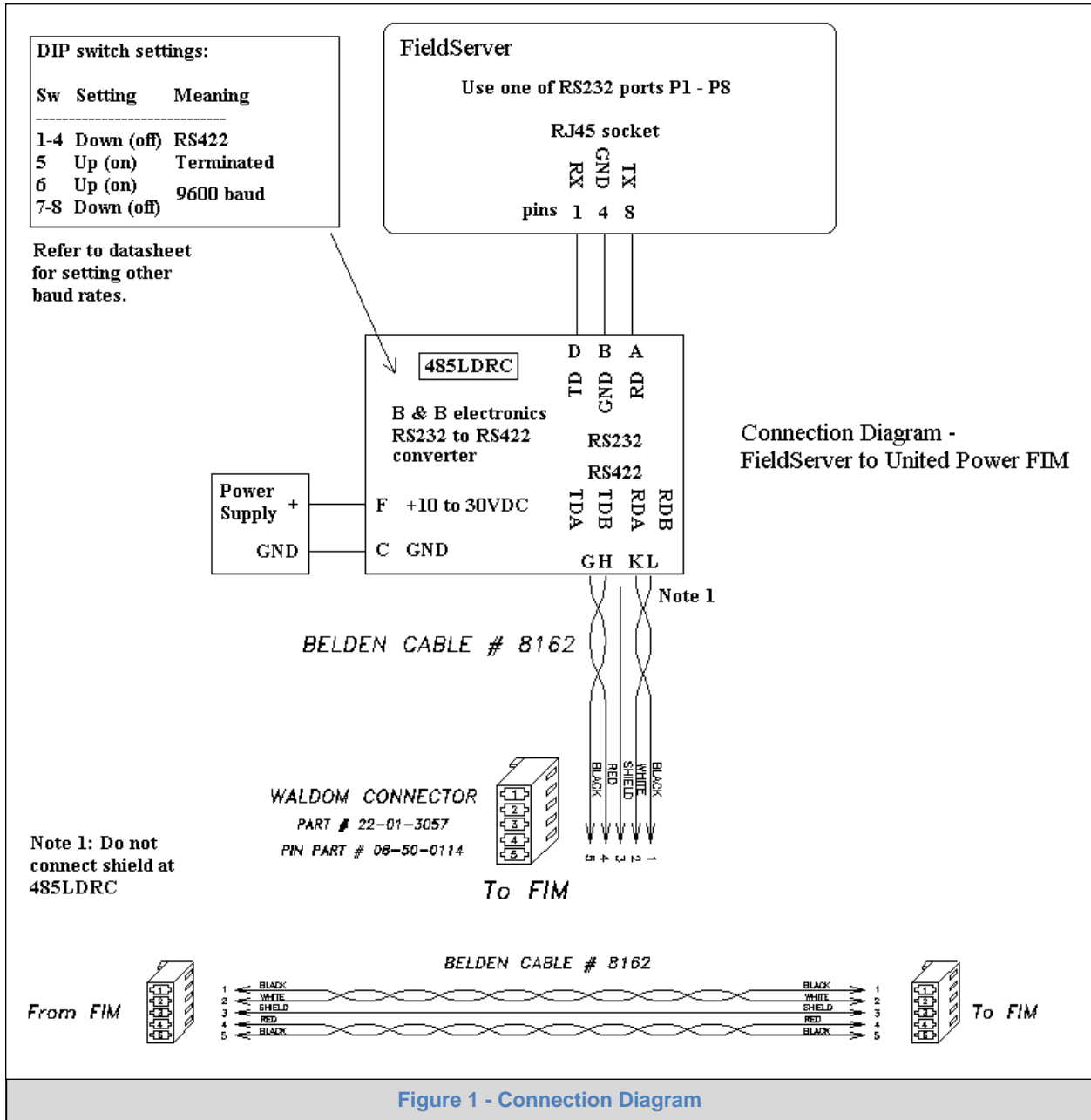

3.1 Hardware Connection Tips / Hints

Note the usage of FIM module addresses as indicated in the manufacturer's user manual. The first address is used for analogue data and the address +1 is used for digital data.

4 CONFIGURING THE FIELDSEVER AS A UNITED POWER FIM CLIENT

For a detailed discussion on FieldServer configuration, please refer to the FieldServer Configuration Manual. The information that follows describes how to expand upon the factory defaults provided in the configuration files included with the FieldServer (See “.csv” sample files provided with the FS).

This section documents and describes the parameters necessary for configuring the FieldServer to communicate with United Power FIM modules.

4.1 Data Arrays/Descriptors

The configuration file tells the FieldServer about its interfaces, and the routing of data required. In order to enable the FieldServer for United Power FIM communications, the driver independent FieldServer buffers need to be declared in the “Data Arrays” section, the destination device addresses need to be declared in the “Client Side Nodes” section, and the data required from the servers needs to be mapped in the “Client Side Map Descriptors” section. Details on how to do this can be found below.

Note that in the tables, * indicates an optional parameter, with the bold legal value being the default.

Section Title		
Data_Arrays		
Column Title	Function	Legal Values
Data_Array_Name	Provide name for Data Array	Up to 15 alphanumeric characters
Data_Array_Format	Provide data format. Each Data Array can only take on one format.	Float, Bit, UInt16, SInt16, Packed_Bit, Byte, Packed_Byte, Swapped_Byte
Data_Array_Length	Number of Data Objects. Must be larger than the data storage area required by the Map Descriptors for the data being placed in this array.	1-10,000

Example

```

// Data Arrays
Data_Arrays
Data_Array_Name      , Data_Format      , Data_Array_Length
Analog_01            , UInt16            , 33
Digital_01           , UInt16            , 1
```

4.2 Client Side Connection Descriptions

Section Title		
Connections		
Column Title	Function	Legal Values
Port	Specify which port the device is connected to the FieldServer	FS-X40 Servers: P1-P8 FS-X20 Servers: P1
Protocol	Specify protocol used	FIM
Baud*	Specify baud rate	9600
Parity*	Specify parity	None
Data_Bits*	Specify data bits	8
Stop_Bits*	Specify stop bits	1
Poll_Delay*	Time between internal polls	> = 0.2s , 1 second

Example

```
// Client Side Connections
Connections
Port      , Protocol      , Baud      , Parity      , Poll_Delay
P1       , FIM          , 9600     , None       , 0.5s
```

4.3 Client Side Node Descriptors

Section Title		
Nodes		
Column Title	Function	Legal Values
Node_Name	Provide name for node	Up to 32 alphanumeric characters
Node_ID	FIM module address	1-255 (use only odd or even addresses for multiple modules)
Protocol	Specify protocol used	FIM
Connection	Specify which port the device is connected to the FieldServer	FS-X40 Servers: P1-P8 FS-X20 Servers: P1

Example

```
// Client Side Nodes
Nodes
Node_Name      , Node_ID      , Protocol      , Connection
FIM_01        , 1            , FIM          , P1
FIM_02        , 2            , FIM          , P1
```

4.4 Client Side Map Descriptors

4.4.1 FieldServer Related Map Descriptor Parameters

Column Title	Function	Legal Values
Map_Descriptor_Name	Name of this Map Descriptor	Up to 32 alphanumeric characters
Data_Array_Name	Name of Data Array where data is to be stored in the FieldServer	One of the Data Array names from "Data Array" section above
Data_Array_Offset	Starting location in Data Array	0 to maximum specified in "Data Array" section above
Function	Function of Client Map Descriptor	RDBC

4.4.2 Driver Related Map Descriptor Parameters

Column Title	Function	Legal Values
Node_Name	Name of Node to fetch data from	One of the node names specified in "Client Node Descriptor" above
FIM_Command	Data poll command	Input_Voltage_AB, Input_Voltage_BC, Input_Voltage_CA, Output_Voltage_AB, Output_Voltage_BC, Output_Voltage_CA, Current_Phase_A, Current_Phase_B, Current_Phase_C, Current_Neutral, Current_Ground, Frequency, Temperature, Humidity, Total_kVA, Perc_Load_Phase_A, Perc_Load_Phase_B, Perc_Load_Phase_C, Total_kW, kW_Phase_A, kW_Phase_B, kW_Phase_C, Pwr_Fact_Phase_A, Pwr_Fact_Phase_B, Pwr_Fact_Phase_C, kW_Hours_Phase_A, kW_Hours_Phase_B, kW_Hours_Phase_C, Peak_Demand, Dist_Perc_Phase_A, Dist_Perc_Phase_B, Dist_Perc_Phase_C, Event_Counter, Digital_Contact

4.4.3 Timing Parameters

Column Title	Function	Legal Values
Scan_Interval	Rate at which data is polled	≥0.001s

4.4.4 Map Descriptor Example.

Map_Descriptor_Name	Scan_Interval	Data_Array_Name	Data_Array_Offset	Function	Node_Name	FIM_Command
CMD1	, 0.2s	, Analog_01	, 0	, RDBC	, FIM_01	, Input_Voltage_AB
CMD2	, 0.2s	, Analog_01	, 1	, RDBC	, FIM_01	, Input_Voltage_BC
CMD3	, 0.2s	, Analog_01	, 2	, RDBC	FIM_01	, Input_Voltage_CA
CMD4	, 0.2s	Digital_01	0	, RDBC	FIM_02	, Digital_Contact

This can be any name but each name must be unique. Name will appear in FieldServer map descriptor status information screens.

The data array name must be one found under Data_Arrays. Data from the scan will be stored into the array at Data_Array_Offset.

This value specifies the offset into the data array where the data fetched will be stored.

Function may not be write. Only read, continuous optionally, allowed.

Node name must be one found under Nodes, Node_Name. Data will be fetched from this node during a poll. Remember that analog data is available from node_x and digital from node_x+1 although it comes from the same device.

FIM commands may be one of several commands specified in the table e.g. Frequency

5 CONFIGURING THE FIELD SERVER AS A UNITED POWER FIM SERVER

For a detailed discussion on FieldServer configuration, please refer to the FieldServer Configuration Manual. The information that follows describes how to expand upon the factory defaults provided in the configuration files included with the FieldServer (See “.csv” files on the driver diskette).

This section documents and describes the parameters necessary for configuring the FieldServer to communicate with a United Power FIM Client.

The configuration file tells the FieldServer about its interfaces, and the routing of data required. In order to enable the FieldServer for United Power FIM communications, the driver independent FieldServer buffers need to be declared in the “Data Arrays” section, the FieldServer virtual node(s) needs to be declared in the “Server Side Nodes” section, and the data to be provided to the client’s needs to be mapped in the “Server Side Map Descriptors” section. Details on how to do this can be found below

Note that in the tables, * indicates an optional parameter, with the bold legal value being the default.

5.1 Server Side Connection Descriptors

Section Title			
Connections	Column Title	Function	Legal Values
	Port	Specify which port the device is connected to the FieldServer	FS-X40 Servers: P1-P8 FS-X20 Servers: P1
	Protocol	Specify protocol used	FIM
	Baud*	Specify baud rate	9600
	Parity*	Specify parity	None
	Data_Bits*	Specify data bits	8
	Stop_Bits*	Specify stop bits	1

Example

```

// Server Side Connections

Connections
Port      , Protocol  , Baud   , Parity
P1       , FIM       , 9600  , None
    
```

5.2 Server Side Node Descriptors

Section Title		
Nodes		
Column Title	Function	Legal Values
Node_Name	Provide name for node	Up to 32 alphanumeric characters
Node_ID	FIM module address	1-255 (if multiple nodes, use only odd or even numbers)
Protocol	Specify protocol used	FIM

Example

```
// Server Side Nodes

Nodes
Node_Name      , Node_ID      , Protocol
FIM_01         , 1          , FIM
FIM_02         , 2          , FIM
```

5.3 Server Side Map Descriptors

5.3.1 FieldServer Specific Map Descriptor Parameters

Column Title	Function	Legal Values
Map_Descriptor_Name	Name of this Map Descriptor	Up to 32 alphanumeric characters
Data_Array_Name	Name of Data Array where data will be stored in the FieldServer	One of the Data Array names from "Data Array" section above
Data_Array_Offset	Starting location in Data Array	0 to maximum specified in "Data Array" section above
Function	Function of Server Map Descriptor	Passive

5.3.2 Driver Specific Map Descriptor Parameters

Column Title	Function	Legal Values
Node_Name	Name of FIM module that holds data	One of the node names specified in "Server Side Node Descriptors" above

5.3.3 Map Descriptor Example.

Map_Descriptor_Name	Data_Array_Name	Data_Array_Offset	Function	Node_Name
SMD1	Analog_01	0	Passive	FIM_01
SMD2	Digital_01	0	Passive	FIM_02

This can be any name but each name must be unique. Name will appear in FieldServer map descriptor status information screens.

The data array name must be one found under Data_Arrays. This data will be sent to a requesting client.

This value specifies the offset into the data array from where data will be sent to a requesting client.

Function may not be read or write since it implements a server. Function may only be passive.

Node name must be one found under Nodes, Node_Name. Polls from a client to this node will be answered with data from this map descriptor. Remember that analog data is sent from node_x and digital data from node_x+1 although it comes from the same device.