

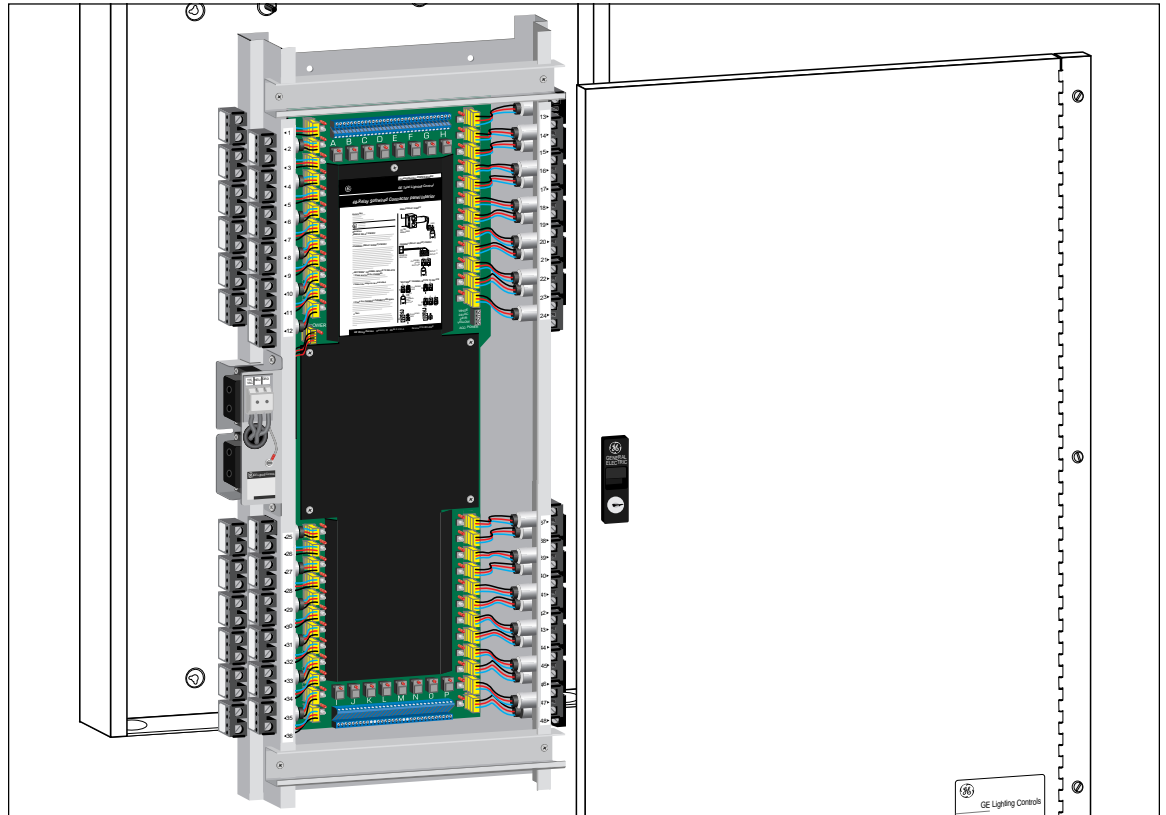

## 48-Relay Softwired Contactor Panel Interior



### DESCRIPTION

The RINTER4848SC is the interior for a 48-relay TLC Softwired Contactor Panel. A complete assembly will include the following:

1. Tub (RTUB48)
2. Interior (RINTER4848SC)
3. Power Supply (RPWRxxx)
4. Cover (RCOV48xxx)

The Softwired Contactor provides a simple way to group lighting circuits by function for both manual and automatic control. For example, in a store application, several display-, showcase- and general-lighting circuits could be grouped for control by three low-voltage switches with pilot indication. A fourth switch could provide master control for all of the lighting and also tie into the building automation scheduling system.

The RINTER4848SC has sixteen separate channels. Each channel can control any combination of the 48 relays (lighting circuits). Channel switches within the panel provide built-in override capability. Two independent inputs per each allow both remote manual switches and automation contacts to control that group.

Automation system distributed control modules may be mounted within the unit to simplify wiring (requires a separate bracket, RACCESSBRK, which is not provided with the interior).

**Before starting, read the installation instructions inside. If you have questions, call:**

**1-877-584-2685 (USA), 1-800-661-6619 (Canada)**

**CAUTION:** Make sure all power is OFF before wiring.  
Do not energize wiring until the unit is fully assembled.  
Conform to all applicable codes.

## INSTALLATION

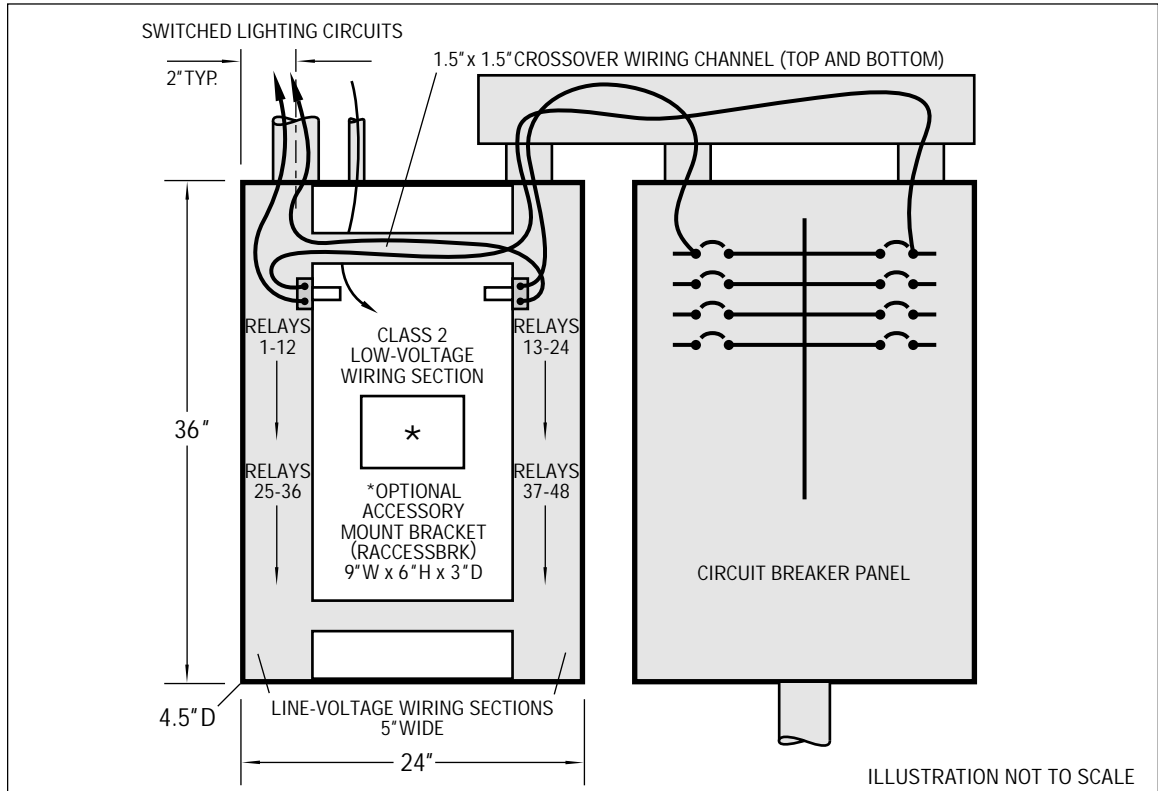

### Rough-in Tub

- Environment**  
 32 to 131°F (0 to 50°C)  
 10 to 95% relative humidity  
 Stationary applications
- Mounting**  
 The tub should be level, plumb and rigidly installed with hardware sufficient to hold 100 lbs. (48kg). The nameplate should be in the upper left corner. For flush-mount panels, the front flange should be flush with the final finished surface. For multiple panels, allow 1/4" minimum between panels for shoebox cover clearance.
- Pulling Wires**  
 Route line-voltage wiring through the 2 1/2" knockouts in either the top or bottom of the tub. Route Class 2 low-voltage wiring from remote switches or other controls through the 3/4" knockouts in either end.

### Install Interior

- Power Supply (RPWRxxx)**  
 Attach the power supply to the left side of the frame and plug the low-voltage connector to the termination marked J2.
- Interior**  
 Mount the interior in the tub and secure it to the studs

with the hardware supplied. Make sure that all line- and low-voltage wiring is confined to the appropriate areas.

### Wire Line-Voltage

Before making any connections to the relay, make sure that none of the load circuits are shorted or miswired. Wire from the circuit breaker through each relay's SPST output terminals, and from there to the loads. Wire the power supply.

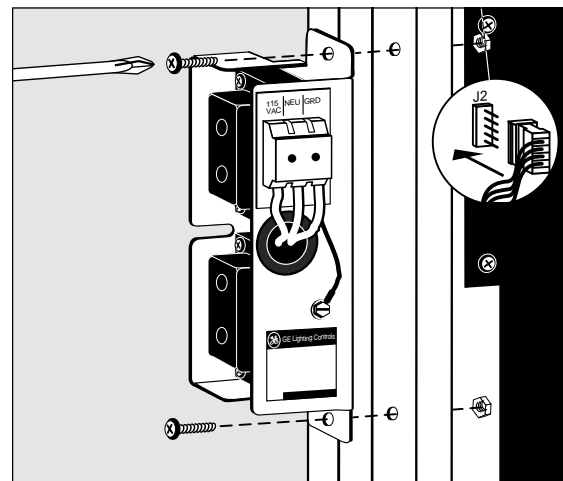

## INSTALLATION

### Wire Low-Voltage

- Remote low-voltage switches and isolated contacts (from a timeclock or building automation system) are wired to the sixteen channel inputs A–P at the top and bottom of the panel. Each channel will accept two inputs, each of which may be either a 2- or 3-wire maintained or momentary device.
- The enclosed insert **Typical Wiring Diagrams** shows common wiring configurations.

### Power Up and Test the Relays

- Apply power to the power supply only. Press the Relay Control Button next to each relay's yellow plug-in termination to toggle it ON/OFF. The relay should "click" and the LED status indicator should change state. Confirm the operation by measuring the line-voltage terminations of each relay.
- Apply power to the relays. Being careful not to touch any line-voltage wiring, toggle each relay ON/OFF again and confirm that each controls the appropriate load.

### Document Wiring

Record the circuit controlled by each relay on the **Wiring Schedule** located on the back page of these installation instructions. Also indicate which relays are controlled by each channel. Place the Schedule in the plastic envelope and attach it to the inside of the panel cover.

### Wire Low-Voltage

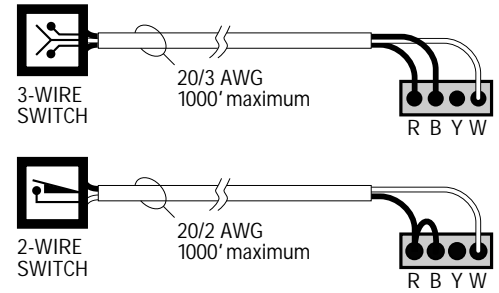

### Power Up and Test the Relays

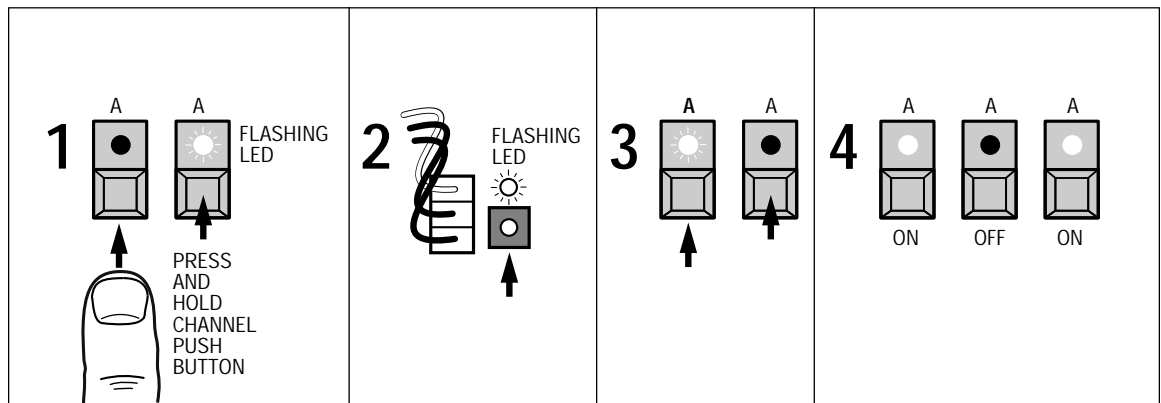
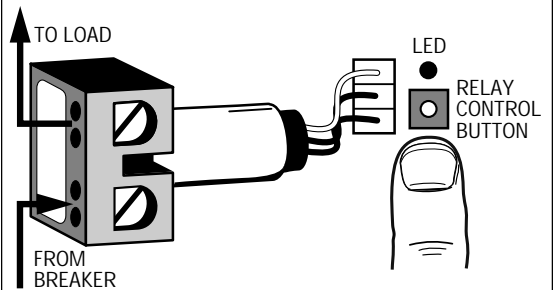

### Softwiring a Relay Group to a Channel

- 1 Press and hold the Channel Push Button for several seconds. The channel LED and the LEDs for relays currently controlled by that input will begin to flash.
- 2 Select the relays to be controlled. The LED for each relay "softwired" to the channel input selected will be flashing ON/OFF. Press the associated Relay Control Button to add/delete that relay to/from the group.
- 3 Press the Channel Push Button again. The LEDs will stop flashing and the input switch will now control the relays selected.
- 4 Test. Press the Channel Push Button to toggle the group ON/OFF/ON. The input LED will track the last action. Now, turn OFF each relay in the group using the individual Relay Control Buttons. When the last relay is turned OFF, the channel LED should also go OFF.

**TYPICAL WIRING DIAGRAMS – AUTOMATION OR TIMECLOCK CONTROL (ISOLATED CONTACTS ONLY)**

**Single-pole, 2-Wire Configuration**

When the control contacts open, the channel is turned OFF; when closed, it is turned ON. Again, you may wire the control contacts to several channels within a panel. However, as with Master Switches on the other side, it is better to define a separate channel to provide the master function. If multiple panels are controlled, the power supplies in each must be on the same phase.

Note: If you are trying to provide multiple OFF sweeps to catch overrides, you should use the 3-wire configuration shown below and wire the timeclock to the OFF (black) input only, or use a timeclock with pulse outputs.

**3-Wire Configuration (C-form contacts)**

When wired as shown, closing the red contact will turn the connected channels ON; the black contact OFF. For multiple OFF sweeps, connect to the OFF contacts only. Automatic ON with multiple OFF sweeps requires two separate control outputs on the timeclock or building automation system.

The timeclock or BAS control module may be mounted to an optional accessory bracket (RACCESSBRK – must be ordered separately). 24 volt AC, 40VA accessory power is provided on the motherboard.

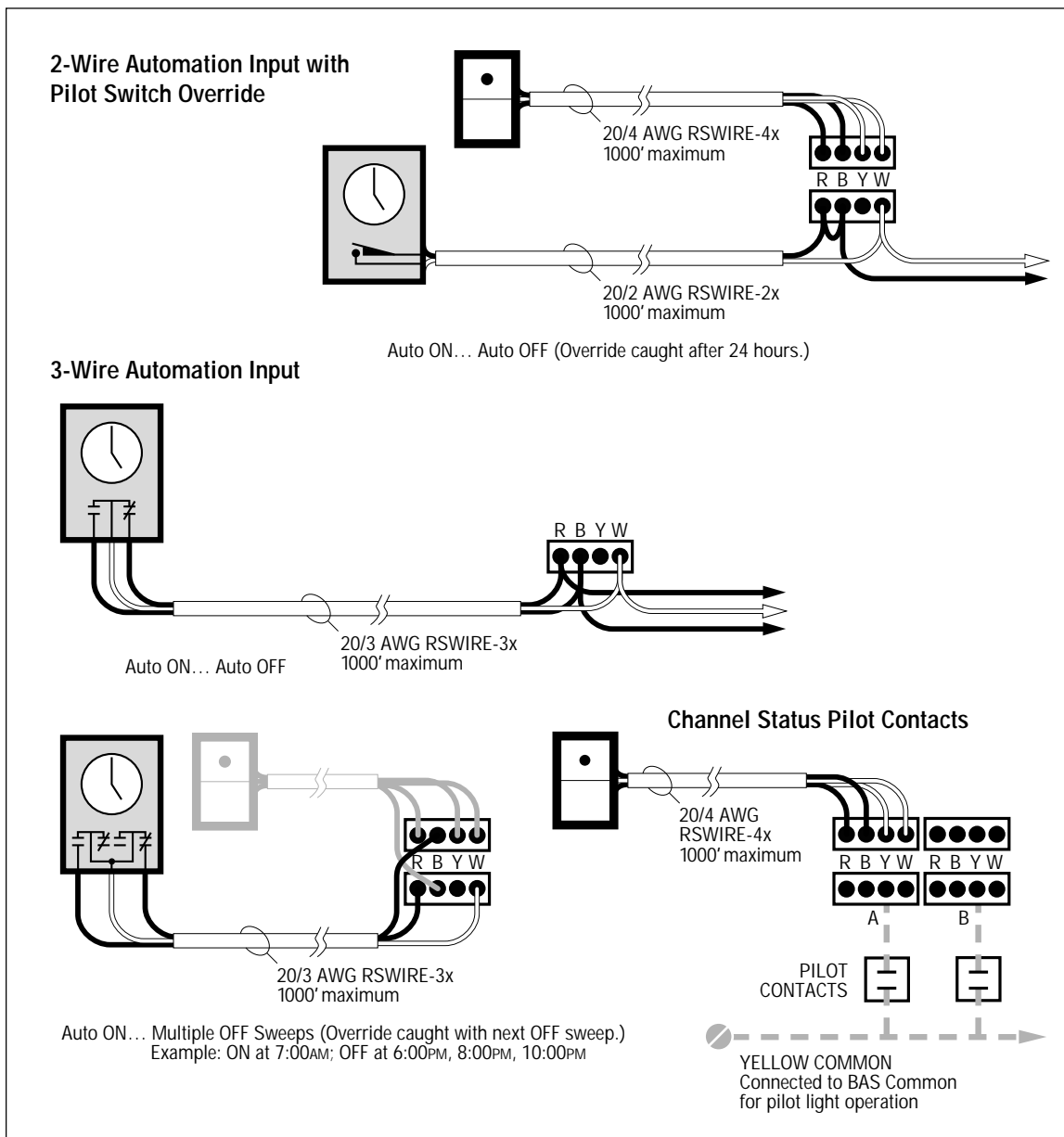

**TYPICAL WIRING DIAGRAMS**

**Remote Manual Switch (3-wire)**

Single or multiple remote low-voltage momentary switches may be wired to a channel input. For multiple switches, a separate black/red is required for each switch plus a single white common.

**Remote Pilot Light Switch (4-wire)**

Each channel has an associated pilot relay rated at 1 amp. One side of the eight pilot relays is connected to a yellow common. The other to the Y terminal on the terminal strip. For typical 24 volt rectified pilot lights, connect the YEL COM to the 24VR in the lower right corner of the board.

**Master Control of Channels in Several Panels**

Channel inputs in multiple panels may be wired in parallel **provided all of the power supplies are wired to the same phase.**

**Master Control of Several Channels within a Panel**

While it is permissible to jumper several switch inputs together to form a master, the recommended approach is to define another channel to include all of the relays controlled by the individual channel switches. When this "master" is turned ON or OFF, all of the individual channel switches will track appropriately.

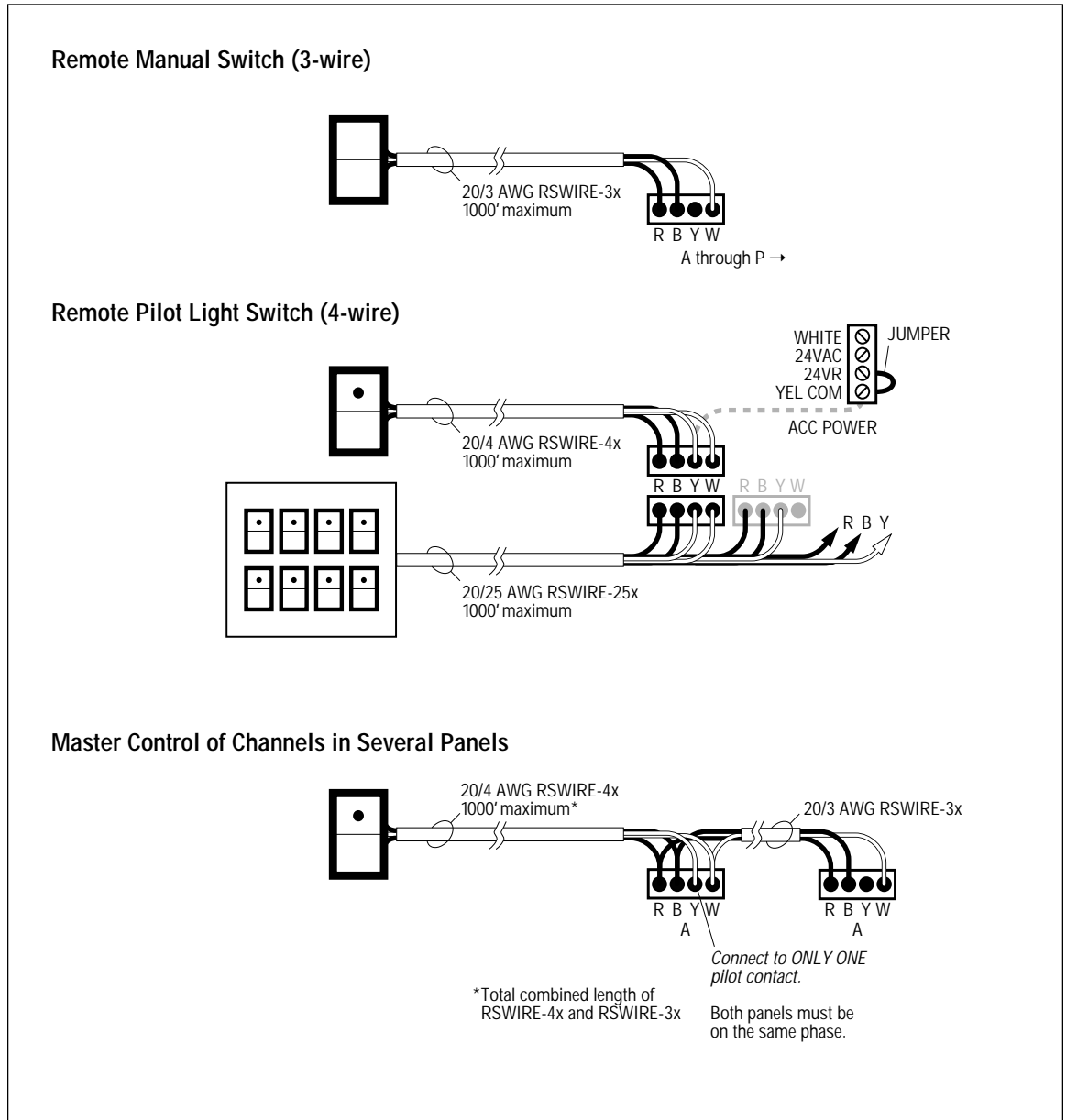

Note: Check those relays which are controlled by each channel under that channel letter below.

**WIRING SCHEDULE: 48-RELAY SOFTWIRED CONTACTOR**

RELAY #	SUPPLY CIRCUIT	LOAD DESCRIPTION	RELAYS CONTROLLED BY EACH CHANNEL															
			A	B	C	D	E	F	G	H	I	J	K	L	M	N	O	P
1																		
2																		
3																		
4																		
5																		
6																		
7																		
8																		
9																		
10																		
11																		
12																		
13																		
14																		
15																		
16																		
17																		
18																		
19																		
20																		
21																		
22																		
23																		
24																		
25																		
26																		
27																		
28																		
29																		
30																		
31																		
32																		
33																		
34																		
35																		
36																		
37																		
38																		
39																		
40																		
41																		
42																		
43																		
44																		
45																		
46																		
47																		
48																		