



Driver Version:	1.00
Document Revision:	3

FieldServer Driver - Serial FS-8700-130 Notifier NCA2/NFS2-3030

Description

The NCA2/NFS2-3030 Serial driver allows the FieldServer to record data from Notifier NCA2 or NFS2-3030 panels over RS-232 as per *NFS2-3030/NCA-2 EIA-232 Protocol & Data Formats 53219 Rev A 1/3/2008*. There is no active polling by this driver; the communications are one-way through the panel's printer or CRT port. The FieldServer acts as a Client; receives messages and records the status of a Panel. The panel MUST output messages in 160 characters ASCII format in English.

This driver is not capable of emulating a Notifier NCA2 or NFS-3030 panel.

The NCA2 controls all the devices (e.g. 3030, 640 panels) connected on the Notifier network. Each Fire Alarm Panel on Network is considered as a Node. 240 Nodes can exist on one network. NFS2-3030 can exist on a network or be self-standing.

NCA2 interacts with other Fire Alarm Panels, records the status of the panels and sends the events to printer and CRT ports. FieldServer captures these events in text form, parses and stores them in Data Arrays. These Data Arrays can be monitored by third party tools. Since the FieldServer does not actively poll for data, the accuracy and timeliness of the stored data is limited to the frequency of update messages that the Notifier Fire Panel issues.

If a networked panel does not send the 'CLEARED' message for latched points via the NCA2 it is not possible to detect cleared points unless a system reset is done. It is possible to configure the FieldServer to clear on reset message from NCA2. See Driver Manual for more detail.

Please note that the FieldServer can be configured with a large number of points. The point limits purchased with the FieldServer prevent the entire database from being accessed in any one application. It is therefore strongly advisable to ensure that only the point addresses of interest are configured, and that the FieldServer is purchased with the correct point count.

The types of Notifier messages supported by this driver are summarized later in the manual. A detailed table shows each type of NCA2/NFS2-3030 message the FieldServer recognizes and the effect that it has on the status of the points in the Data Array.

Fieldserver Mode	Nodes	Comments
Client	1	Each FieldServer port can connect to only 1 Notifier panel
Server	0	This driver cannot be used as a Server.

Formal Driver Type

Serial
Client



Connection Information

Connection type: RS-232
CRT Port

Baud Rates: 4800; **9600**; 19200; 38400; 57600; (Vendor limitation)
Printer Port
9600 (Vendor limitation)

Data Bits: **8** (Device limitation)

Stop Bits: **1** (Device limitation)

Parity: **None** (Device limitation)

Multidrop Capability No

Devices Tested:

Device	Tested (FACTORY, SITE)
NCA2	Site
NFS2-3030	Site

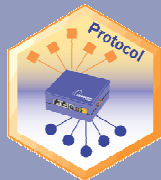

Connection configurations

The FieldServer is connected to the Notifier NCA2/NFS2-3030 Fire Panel as shown in the following connection drawing.

Configure the Notifier Panel according to manufacturer's instructions.

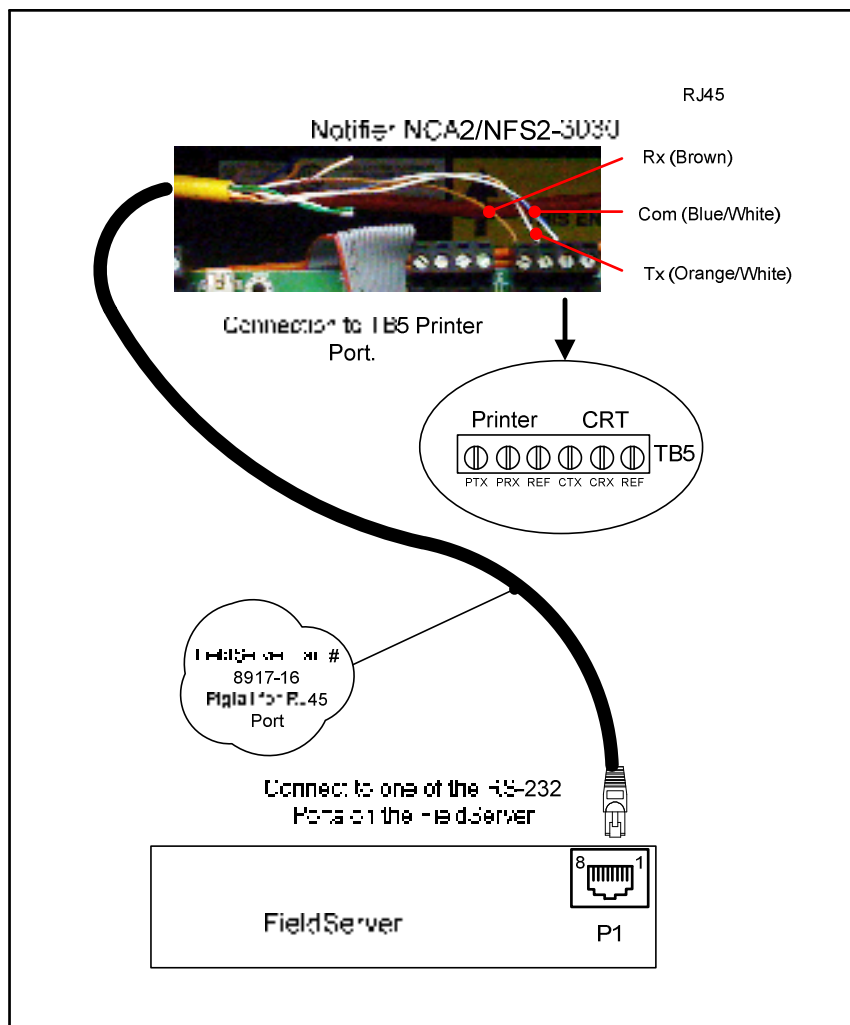

Connector Pinouts

TB5 CRT	Function	Receive	Reference	Transmit
	Pin	CRX	REF	CTX
TB5 Printer	Function	Receive	Reference	Transmit
	Pin	PRX	REF	PTX
RJ-45	Function	Transmit	Com	Receive
	Pin	8	4	1
Wire Color		Orange/white	Blue/white	Brown



Hardware Connection Tips / Hints

- The FieldServer should preferably be connected to the TB5 Printer port. It is theoretically possible to connect to the TB5 CRT port, but this has not been fully tested.
- The Panel's port must be enabled and set to 80 Columns Not Supervised.

Communications functions - Supported functions at a glance:

Message Types Supported

The primary purpose of this driver is to record the status of devices connected to the Notifier panel by interpreting the text messages sent to the printer or CRT port. Not all messages will be interpreted, as many messages do not directly pertain to device status, or are not currently supported. The following subset of event messages is recognized:

Active Events:
FIRE ALARM
SECURITY ALARM (LIFE)
LIFE CRITICAL ALARM
MEDICAL EMERGENCY
SECURITY ALARM
CRITICAL PROCESS
SUPERVISORY
TROUBLE/ FAULT
DISABLED
PREALARM
ACTIVE
ON/ OFF

A detailed mapping of message interaction System Trouble messages provided by Notifier at the time this driver was written is tabulated in the Driver Manual. Any changes or additions by Notifier will not be reflected in this driver unless specifically revised.

Zone Status:

This driver will not record information about zone status that is incorporated with point status messages. A device can belong to multiple zones, however, only the primary zone is listed in the printer output. This severely limits the accuracy of zone data based on event generated messages, and therefore will not be recorded.

Panel Status: Memory Mapping:

This Driver divides the memory into various types. Each location in each memory type is assigned an address. It is therefore possible to map an address to a particular offset in a Data Array and make it accessible for reading by other connected devices. The address structure is provided below.

Most of these addresses will only contain binary information to represent an active or inactive state.

Where multiple troubles are associated with a single device the addressed register corresponding to that device will be incremented as a counter for each trouble message and decremented when a trouble is cleared. These addresses should preferably be stored in SINT16 format in the Data Array.



Parameter	Addresses
For each SLC loop per Node	
Memory Type : Detector ; Module	
Fire Alarm	1 – 159
Security Life	160 – 318
Life Critical	319 – 477
Medical Emergency	478 – 636
Security Alarm	637 – 795
Critical Process	796 – 954
Supervisory	955 - 1113
Disabled	1114 – 1272
Prealarm	1273 – 1431
Active	1432 – 1590
ON/OFF	1591 – 1749
Memory Type : Detector_Trouble; Module_Trouble	
Troubles/Faults	1 – 159

Parameter	Addresses
For each Node	
Memory Type : Node_Trouble	
Troubles/Faults	1 – 508
Memory Type : Panel	
Panel (Maximum 12 Boards and 8 Panel circuits per Board)	
Hardware address	memory address
Board 1 panel 1	1
Board 1 panel 2	2
Board 2 panel 1	9

Board 12 panel 8	96
)	
Fire Alarm	1 – 96
Security Life	97 - 192
Life Critical	193 - 288
Medical Emergency	289 - 384
Security Alarm	385 - 480
Critical Process	481 - 576
Supervisory	577 - 672
Disabled	673 - 768
Prealarm	769 - 864
Active	865 - 960
ON/OFF	961 - 1056
Memory Type : Panel_Trouble	
Troubles/Faults	1-96
Memory Type : Bell_Trouble	
Troubles/Faults	1-4



Driver Limitations & Exclusions

- Zone information will not be recorded.
- To synchronize the FieldServer with the panel, connect the running FieldServer and press the "System Reset" button on the panel. All current events will be re-sent to the FieldServer.
- The port must be enabled on the unit and set to 80 columns with NO supervision
- All data related to non-event driven reports will not be recorded by the FieldServer
- This driver was written as a subset of *NFS2-3030/NCA-2 EIA-232 Protocol & Data Formats 53219 Rev A 1/3/2008*. Any changes or additions by Notifier will not be reflected in this driver unless specifically revised.
- This driver will not record information about zone status that is incorporated with point status messages.
- There can only be one panel connected to any given FieldServer port.
- This driver records data as presented to the printer/CRT port by the Notifier panel, and can only be as accurate as this data.
- The driver cannot send messages to the Notifier panel.
- Driver will clear any data on "System Normal" only if this data is previously set by driver and is not yet cleared by "Cleared" message and is configured to Clear_on_Normal. By default Clear_on_Normal is "yes".
- Driver will clear any Node data on "System RESET" only if this data is previously set by driver and is not yet cleared by "Cleared" message and is configured to Clear_on_Reset. By default Clear_on_Reset is "no".